



GE Fanuc Automation

Programmable Control Products

***Field Control® Distributed I/O
and Control System***

I/O Modules User's Manual

GFK-0826J

June 2002

Warnings, Cautions, and Notes as Used in this Publication

Warning

Warning notices are used in this publication to emphasize that hazardous voltages, currents, temperatures, or other conditions that could cause personal injury exist in this equipment or may be associated with its use.

In situations where inattention could cause either personal injury or damage to equipment, a Warning notice is used.

Caution

Caution notices are used where equipment might be damaged if care is not taken.

Note

Notes merely call attention to information that is especially significant to understanding and operating the equipment.

This document is based on information available at the time of its publication. While efforts have been made to be accurate, the information contained herein does not purport to cover all details or variations in hardware or software, nor to provide for every possible contingency in connection with installation, operation, or maintenance. Features may be described herein which are not present in all hardware and software systems. GE Fanuc Automation assumes no obligation of notice to holders of this document with respect to changes subsequently made.

GE Fanuc Automation makes no representation or warranty, expressed, implied, or statutory with respect to, and assumes no responsibility for the accuracy, completeness, sufficiency, or usefulness of the information contained herein. No warranties of merchantability or fitness for purpose shall apply.

The following are trademarks of GE Fanuc Automation North America, Inc.

Alarm Master	Genius	PowerTRAC	Series Six
CIMPLICITY	Helpmate	ProLoop	Series Three
CIMPLICITY 90-ADS	Logicmaster	PROMACRO	VersaMax
CIMSTAR	Modelmaster	Series Five	VersaPoint
Field Control	Motion Mate	Series 90	VersaPro
GENet	PowerMotion	Series One	VuMaster
			Workmaster

Content of This Manual

This manual describes Field Control[®] I/O modules and associated components.

Chapter 1. Introduction: Chapter 1 provides basic information about the Field Control family of products.

Chapter 2. Installation: Chapter 2 summarizes installation instructions for Field Control I/O modules, I/O Terminal Blocks, and cables.

Chapters 3—end. I/O Module Datasheets: The rest of the manual consists of datasheets for individual I/O modules.

Appendix A. Analog Signal Terms: Appendix A provides some definitions of basic analog terms.

Appendix B. Scaling Analog Channels: Appendix A summarizes instructions for analog scaling.

Related Publications

For more information, refer to:

Field Control Genius[®] Bus Interface Unit User's Manual (GFK-0825). This book describes the module that interfaces a group of Field Control I/O modules to a Genius serial bus. It explains how to install and configure a Bus Interface Unit, and describes how a Bus Interface Unit operates.

Field Control FIP Bus Interface Unit User's Manual (GFK-1175). This book describes the module that interfaces a group of Field Control I/O modules to a FIP bus. It explains how to install and configure a Bus Interface Unit, and describes how a Bus Interface Unit operates.

Field Control Profibus Bus Interface Unit User's Manual (GFK-1291). This book describes the module that interfaces a group of Field Control I/O modules to a Profibus. It explains how to install and configure a Bus Interface Unit, and describes how a Bus Interface Unit operates.

Jeanne L. Grimsby

Lead Technical Writer for I/O Products

Chapter 1	Introduction	1-1
	Overview.....	1-1
	I/O Modules	1-2
	Environmental Specifications	1-3
	I/O Terminal Blocks	1-4
	Catalog Numbers of Field Control Equipment	1-12
Chapter 2	Installation	2-1
	Choosing and Installing the DIN Rail.....	2-2
	Installing an I/O Terminal Block on the DIN Rail.....	2-4
	Protective I/O Terminal Block Labels	2-6
	Installing the Cables Between Terminal Blocks	2-7
	Wiring for I/O Modules	2-9
	I/O Module Terminal Assignment Reference Tables	2-10
	Power Wiring.....	2-12
	Discrete I/O Wiring.....	2-13
	Analog I/O Wiring	2-14
	Module Installation.....	2-15
	Installing an I/O Module on the Base	2-16
	Hot Insertion/Removal of Modules.....	2-17
Chapter 3	120VAC Isolated Discrete Input Module IC670MDL233	3-1
Chapter 4	120VAC Grouped Discrete Input Module IC670MDL240.....	4-1
Chapter 5	240VAC Discrete Input Module IC670MDL241	5-1
Chapter 6	24VDC Positive/Negative Discrete Input Module IC670MDL640.....	6-1
Chapter 7	48VDC Positive/Negative Discrete Input Module IC670MDL641.....	7-1
Chapter 8	125VDC Positive/Negative Discrete Input Module IC670MDL642.....	8-1
Chapter 9	5/12VDC Positive/Negative Discrete Input Module IC670MDL643.....	9-1
Chapter 10	24VDC Positive/Negative Fast Discrete Input Module IC670MDL644	10-1
Chapter 11	12-120VAC 1.0A Discrete Output Module IC670MDL330.....	11-1
Chapter 12	120VAC Isolated 2A Discrete Output Module IC670MDL331.....	12-1

Contents

Chapter 13	24VDC Positive Logic ESCP Discrete Output Module IC670MDL730.....	13-1
Chapter 14	12/24VDC Positive Output Module IC670MDL740.....	14-1
Chapter 15	5/12/24VDC Negative Output Module IC670MDL742.....	15-1
Chapter 16	Relay Isolated NO/NC Output Module IC670MDL930	16-1
Chapter 17	24 VDC Mixed Discrete Input/Output Module IC670MDD441	17-1
Chapter 18	Current Source Analog Input Module IC670ALG230	18-1
Chapter 19	16 Point Grouped Analog Input Module IC670ALG240.....	19-1
Chapter 20	RTD Analog Input Module IC670ALG620.....	20-1
Chapter 21	Thermocouple Analog Input Module IC670ALG630	21-1
Chapter 22	8 Point Isolated Analog Voltage-Source Output Module IC670ALG310	22-1
Chapter 23	Current/Voltage-Source Analog Output Module IC670ALG320.....	23-1
Chapter 24	8 Point Current-Source Analog Output Module IC670ALG330.....	24-1
Appendix A	Analog Signal Terms	A-1
Appendix B	Scaling Analog Channels	B-1

sales@powergearx.com

sales@powergearx.com

sales@powergearx.com

Chapter 1

Introduction

This chapter provides basic information about Field Control® I/O products.

Overview

Field Control is a family of versatile, truly modular I/O products, suitable for use in a wide range of control system architectures.

Field Control **I/O Modules** are small and rugged. They provide easily-configurable discrete and analog I/O interfaces which may also include local intelligence for signal processing.

I/O Terminal Blocks provide universal field wiring terminals for two I/O modules, allowing I/O module types to be mixed on the same I/O Terminal Block. The I/O Terminal block is mounted on a DIN rail. The DIN rail, which is an integral part of the grounding system, must be mounted to a panel.

As many as eight Field Control I/O modules (four I/O terminal blocks) can be connected to one **Bus Interface Unit**. Together, they make up a Field Control “station” **Bus Interface Units** are available for different types of busses, such as Genius, Profibus, and FIP.

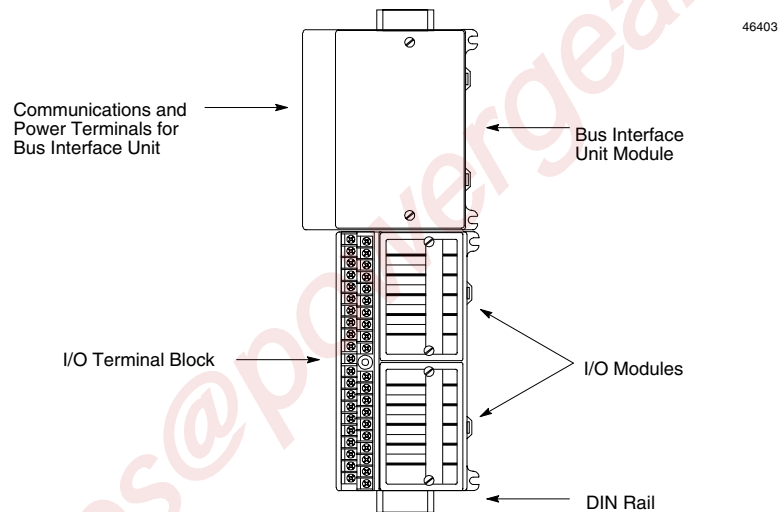

The **Bus Interface Unit** provides the I/O scanning, diagnostics, and communications capabilities needed to link the I/O modules to the control system. In addition, the Bus Interface Unit may provide (and store) configurable characteristics for I/O modules, such as fault reporting, output defaults, analog range selection, and analog scaling.

I/O Modules

Field Control I/O modules are small rugged components with sturdy aluminum housings.

Modules are approximately 3.25 inches (8.2 cm) high x 2 inches (5.25 cm) wide. They are 2.90 inches (7.3 cm) deep (not including the portion that extends into the I/O Terminal Block).

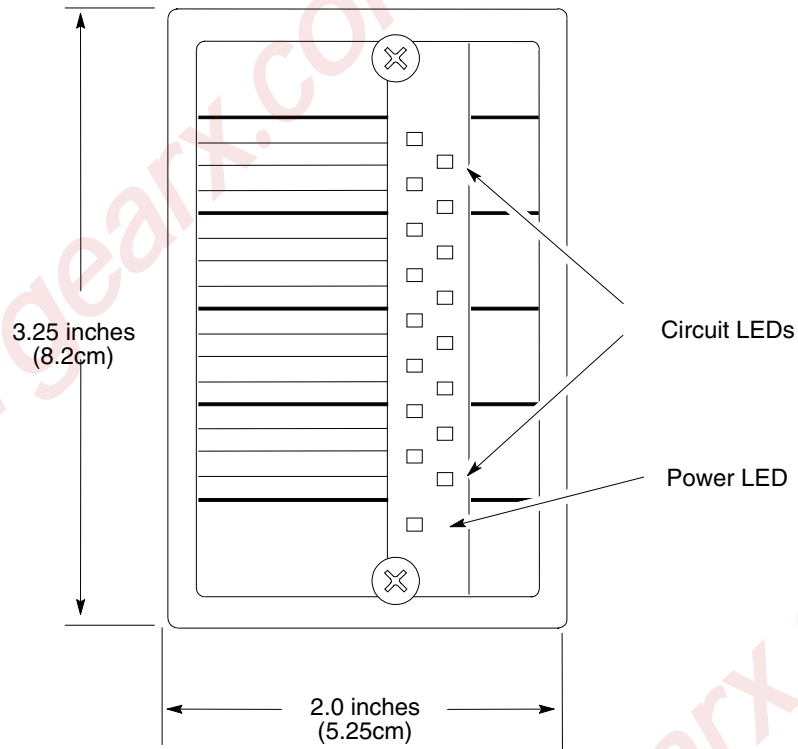

Both discrete and analog conventional input and output modules are available. In addition, intelligent modules, which perform more advanced functions, are also available. Examples of intelligent modules are the Micro Field Processor, the 16-point Grouped Analog Input module (IC670ALG240), the Thermocouple Input module (IC670ALG630), and the RTD Input module (IC670ALG620).

LEDs

I/O Module LEDs are easily visible through the transparent central portion of the label. All modules have an LED that indicates the presence of module power. Discrete modules also have individual circuit LEDs that show the on/off status of each input or output circuit.

Front Label

The module's front label, shown above, has space for writing circuit identifications.

Module Keying

Each type of I/O module is slotted to allow keying. Small key clips (provided) can be inserted into corresponding slots in the I/O base to assure that the module installed in that location will not cause damage or unexpected machine operation. Actual keying slots are the same for some types of modules.

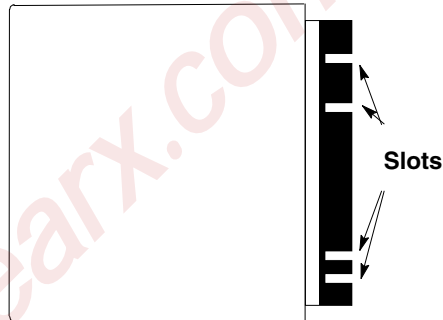

I/O Module (Side View)

For More Information About I/O Modules, See:

- Chapter 2, *Installation*.
- The I/O module datasheets in this manual.
- Configuration instructions in the *Bus Interface Unit User's Manual*.

Environmental Specifications

Vibration	<p>Modules perform well where vibration is a factor. Designs are shock and vibration tested to meet the following specifications when installed on a panel-mounted DIN rail using the clamp supplied, and with the panel-mounting feet secured:</p> <p>IEC68-2-6: 10 to 57 Hz 0.012 in displacement (peak to peak) 57 to 500 Hz at 2 g (unless otherwise specified)</p> <p>IEC68-2-27: Shock: 15G, 11 milliseconds, half sine wave</p>
Noise	<p>Modules are resistant to noise levels found in most industrial applications when installed according to accepted practices, including proper separation of wiring by voltage and power levels, on a conductive (unpainted) DIN rail. The DIN rail is an integral part of the grounding system.</p> <p>Modules are tested to the specifications listed in the <i>Conformance to Standards</i> document (GFK-1079).</p>
Temperature	<p>Modules operate reliably in ambient air temperatures from 0°C (32°F) up to 55°C (131°F).</p> <p>Storage temperatures are -40°C (-40°F) to +85°C (185°F).</p>
Humidity	<p>5% to 95%, non-condensing.</p>

I/O Terminal Blocks

I/O Terminal Blocks are generic wiring bases for Field Control I/O modules. They provide I/O module mounting, backplane communications, and terminals for user connections.

Two I/O modules can be installed on an I/O Terminal Block. Modules screw onto the terminal block for vibration resistance.

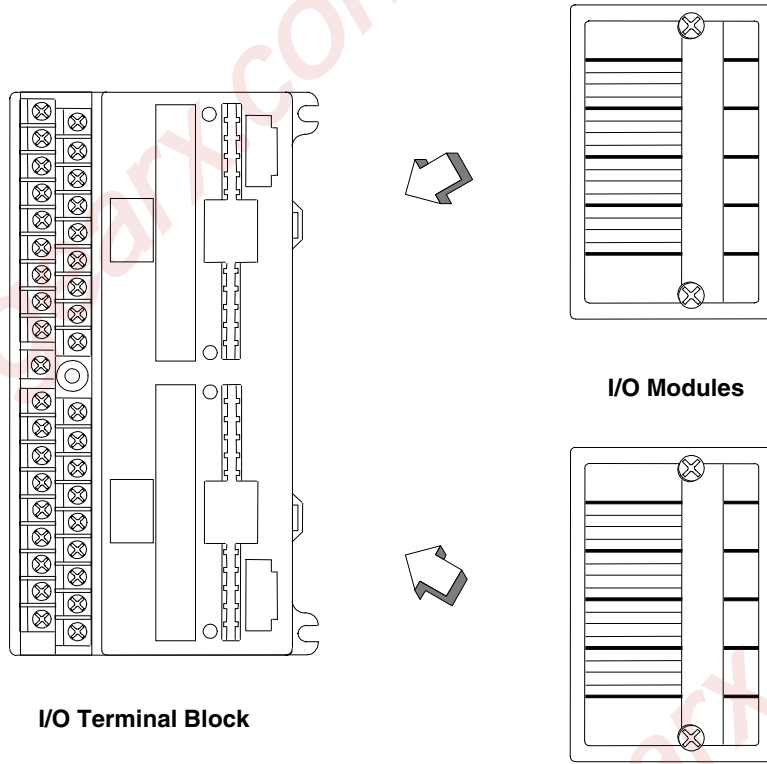

I/O modules can be removed from the I/O Terminal Block without disturbing field wiring.

I/O Terminal Block General Description

The following illustration shows the basic parts of an I/O Terminal Block.

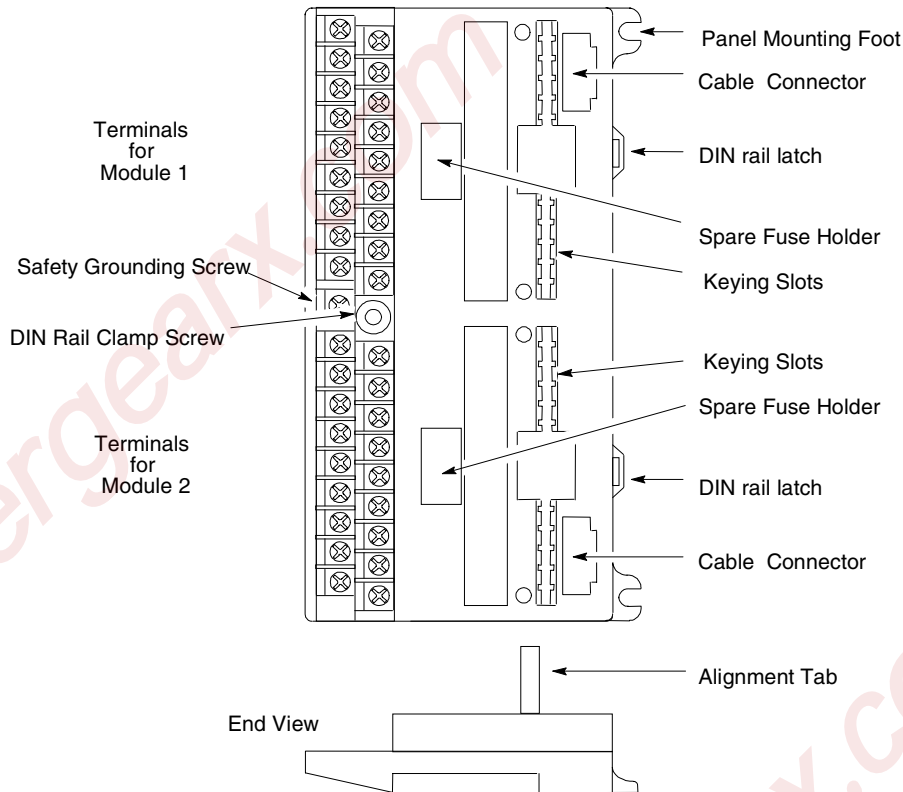

The I/O Terminal Block has two separate sets of **module terminals**. Each set corresponds to a “slot” in a conventional rack-type PLC. Terminal wiring assignments depend on the I/O module type installed in that location.

The **grounding screw** is used to attach a ground wire to the terminal block.

The **cable connectors** provide easy attachment of the cable that carries communications signals between terminal blocks and the Bus Interface Unit.

The **spare fuse holders** can be used to store extra fuses (if needed) for the I/O modules.

The **DIN rail latches** clip the I/O Terminal Block to a DIN rail. Pulling these latches outward releases the DIN rail.

The **keying slots** permit protective keying. Inserting the key clips provided into these slots assures that the module installed in that location will not cause damage or unexpected machine operation.

I/O Terminal Blocks IC670CHS101, 102, and 103 have projecting **alignment tabs** designed to facilitate Hot Insertion/Removal of modules. I/O Terminal Blocks IC670CHS001, 002, and 003, which lack alignment tabs, do not support Hot Insertion/Removal of modules.

Installation

The I/O Terminal Block can be installed in any orientation; the preferred vertical orientation for easier wiring installation is with the wiring terminals on the left and the panel-mounting feet on the right as shown below. The preferred horizontal orientation is with the wiring terminals at the bottom and the mounting feet at the top.

This diagram shows overall dimensions of I/O Terminal Block, and locations for panel-mounting screws

position with terminals on left for easier wiring

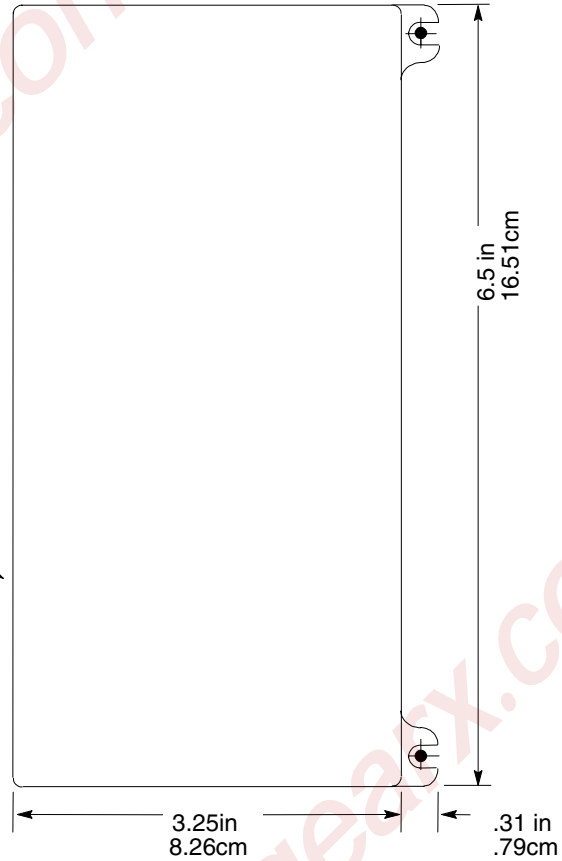

Field Control terminal blocks must be installed on a **35mm x 7.5mm DIN rail**, which becomes an integral part of the grounding system. The DIN rail finish must be electrically conductive. **The DIN rail must not be painted.**

The DIN rail should be mounted on a panel for added vibration resistance.

The overall depth of Field Control modules when mounted on terminal blocks and installed on a 35mm x 7.5mm DIN rail is 4.0 inches (10.16 cm).

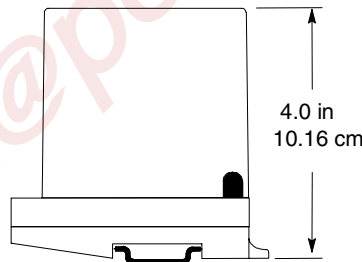

Terminal Styles

I/O Terminal Blocks are available with the I/O terminal styles shown below. I/O Terminal Blocks with different terminal styles can be mixed within an I/O Station.

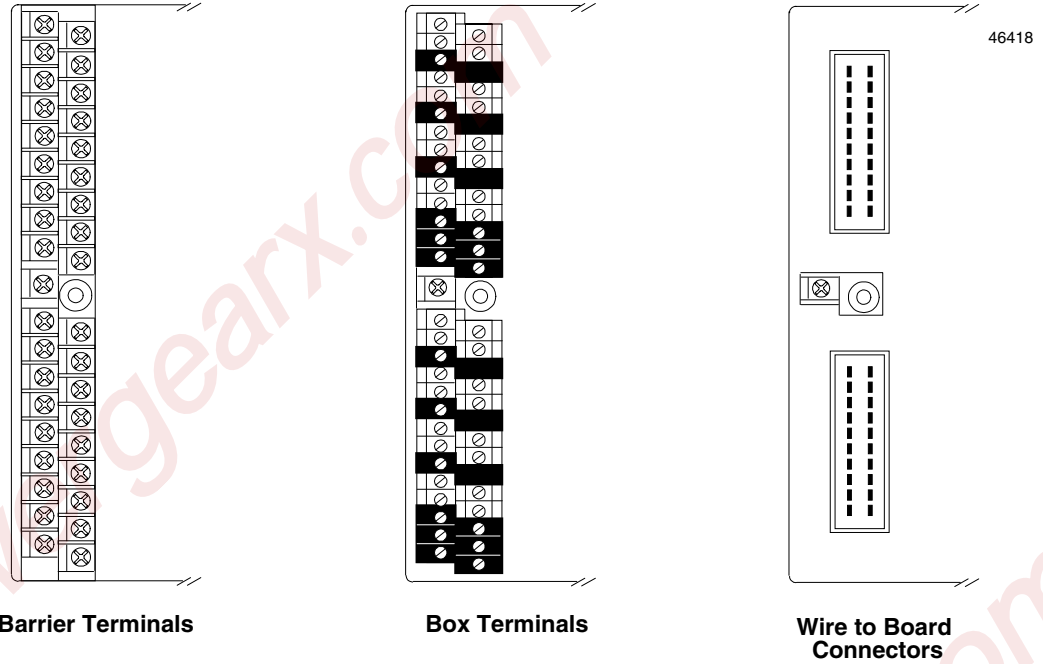

I/O Terminal Block with Barrier Terminals

The I/O Terminal Block with barrier terminals (catalog number IC670CHS001 and 101) has 37 terminals. Each terminal can accommodate one or two wires up to AWG #14 (avg. 2.1mm^2 cross section).

I/O Terminal Block with Box Terminals

The Terminal Block with box terminals (catalog number IC670CHS002 and 102) has 51 terminals, each of which accommodates one AWG #14 (avg. 2.1mm^2 cross section) to AWG #22 wire (avg. 0.36mm^2 cross section), or two wires up to AWG #18 (avg. 0.86mm^2 cross section). An insulated external 5mm (0.2in) jumper such as Altech #8879 can be used to connect adjacent points. When an external jumper is used, the wire capacity is reduced from AWG #14 (2.10mm^2) to AWG #16 (1.32mm^2).

Wire to Board Connectors

The I/O Terminal Block with Connectors (catalog number IC670CHS003 and 103) has two 20-pin male connectors for I/O wiring. The mating connector is Amp part number 178289-8. The connectors are keyed to prevent wrong insertion. Any tin-plated contact in the AMP D-3000 series can be used with the connector (Amp part number 1-175217-5 for high contact force receptacle for 20-24 gauge ($0.20\text{-}0.56\text{mm}^2$) wires), 1-175218-5 for high contact force receptacle for 16-20 gauge ($0.56\text{-}1.42\text{mm}^2$). A kit containing two mating connector housings and contacts is available as GE Fanuc part number IC670ACC003. The kit contains pins for 16-20 gauge wire. A crimping tool is not provided in this kit.

Tie Point Terminals on Box-Style I/O Terminal Blocks

Although each terminal on an I/O Terminal Block with Box Terminals normally accommodates only one wire, there are five extra tie point terminals for each I/O module position. The maximum current through any one terminal is 10 Amps. (These extra terminals are not available with the barrier-style I/O Terminal Block, which can accommodate up to two wires per terminal).

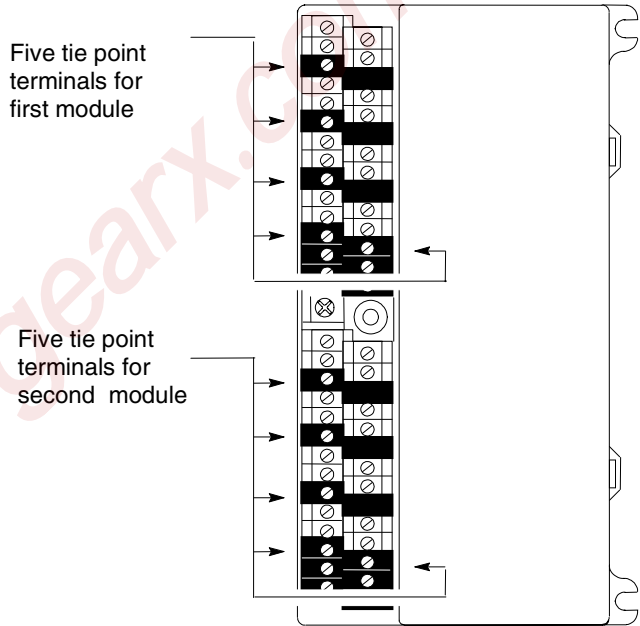

The five tie-point terminals are internally tied together and isolated from the power and point terminals. They can be used for connecting isolated discrete points into groups, or in some analog applications, where extra connections to a power supply or common are needed. (For 16-point modules, an Auxiliary Terminal Block is also needed).

This I/O Terminal Block also has extra power terminals for each module. These terminals make it easy to daisy-chain power wiring between modules.

Snap-in Labels for Box-Style Terminals

Snap-in terminal labels for the box-style I/O Terminal Block can be ordered from a Weidmüller distributor. Custom printed labels (Dekafix 5, part number 490760000) are available in large quantities. Several styles of labels preprinted with letters, numbers, or symbols are available in smaller quantities. For the name and telephone number of a distributor in your area, call Weidmüller at 1-800-849-9343 or 1-804-794-2877.

Auxiliary I/O Terminal Blocks

Auxiliary Terminal Blocks can be used to provide the extra wiring terminals needed for analog and high-density discrete I/O modules. They can also be used to provide extra ground, return, or common connections. All terminals on Auxiliary Terminal Block are electrically connected together internally.

Auxiliary Terminal Blocks attach to an I/O Terminal Block as shown below.

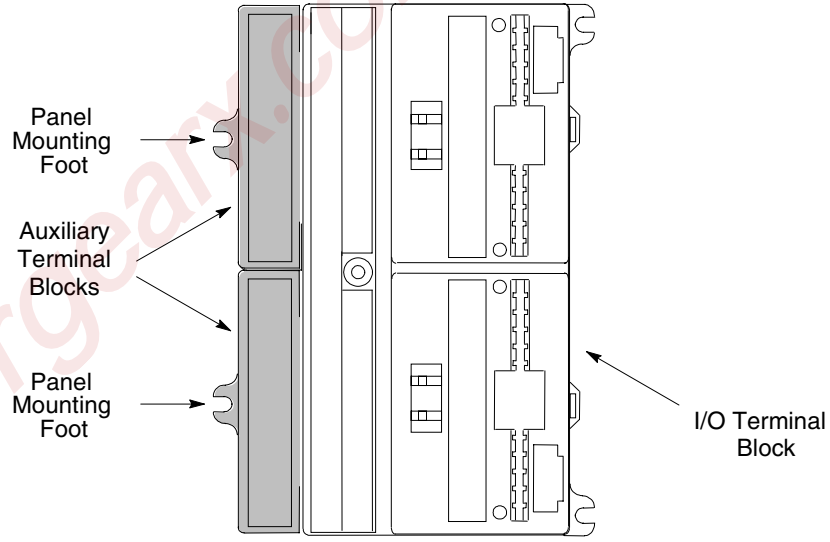

Versions are available with barrier-type terminals (catalog number IC670TBM001) and box-type terminals (IC670TBM002)

Auxiliary Terminal Block with Barrier Terminals

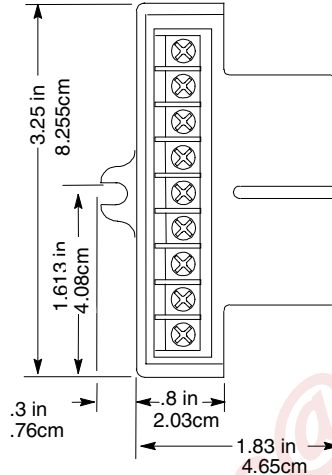

Auxiliary Terminal Block with Box Terminals

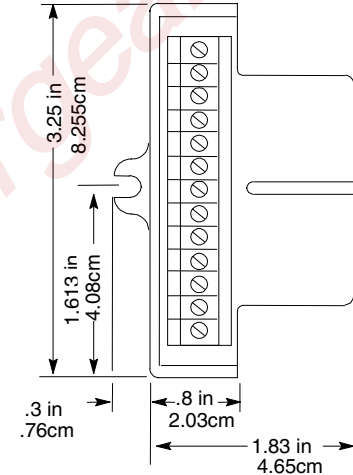

Note: The panel-mounting feet must be used to meet the product vibration specifications.

Thermocouple Terminal Block

The Thermocouple Terminal Block (IC670CHS004), which has two built-in thermistors, can be used to provide local reference junction compensation for thermocouples used in conjunction with Field Control Thermocouple modules.

Thermocouples are connected to the screw terminals on the Thermocouple Terminal Block.

Thermocouple modules are installed on a separate I/O Terminal Block (IC670CHS003, -002, or -001) and connected to Wire-to-Board connectors on the Thermocouple Terminal Block. Terminal Block IC670CHS003 provides connector to connector installation.

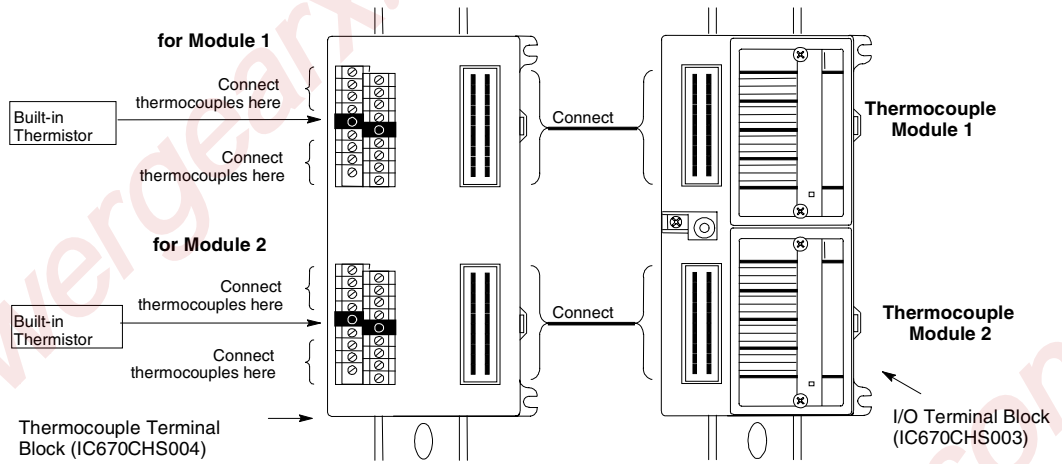

Base Connection Cables

A short connecting cable, illustrated below, is supplied with each I/O Terminal Block. A set of connecting cables is available as renewal part number IC670ACC001. An optional 21-inch (0.53 meter) cable (IC670CBL002) is also available.

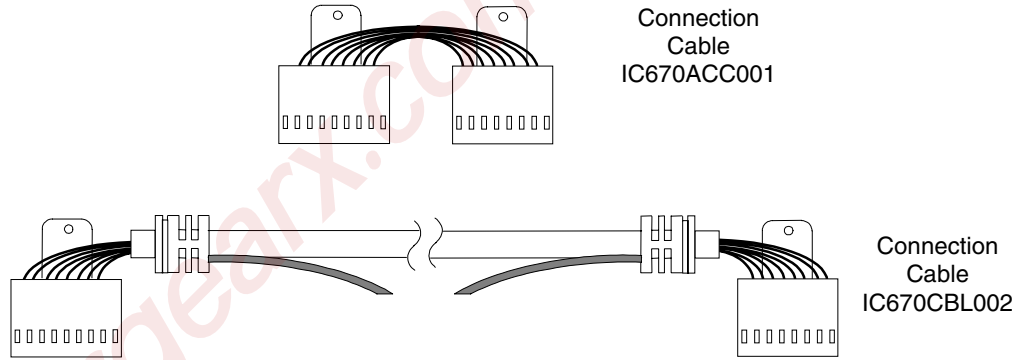

One longer cable can be used per Field Control station. The remaining connections must be made using the shorter connectors supplied with the bases.

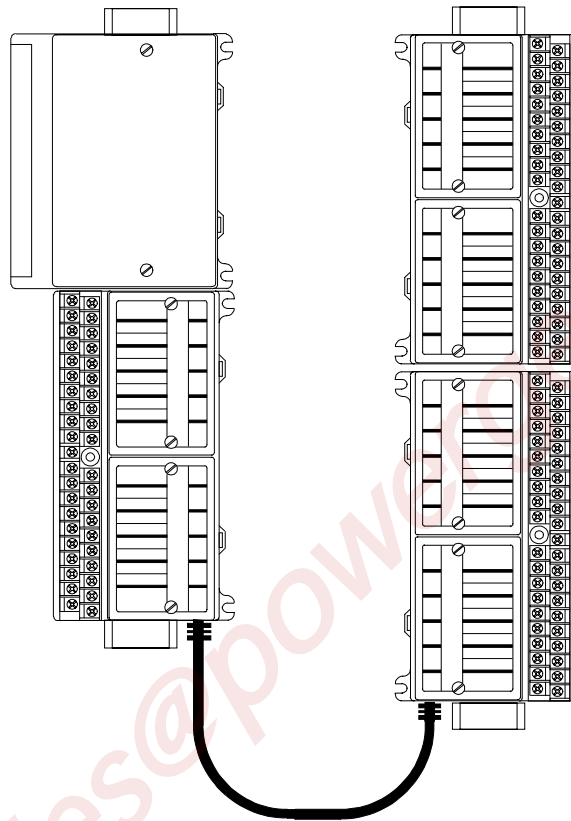

46517

Catalog Numbers of Field Control Equipment

<i>Description</i>	<i>Catalog Number</i>
Bus Interface Unit, Genius	IC670GBI002
Bus Interface Unit, FIP	IC670FBI001
Bus Interface Unit, Profibus	IC670BPI001
Bus Interface Unit, Interbus-S	HE670IBU001
Micro Field Processor	IC670MFP100
I/O Terminal Block with Barrier-style Terminals	IC670CHS001
I/O Terminal Block with Box-style Terminals	IC670CHS002
I/O Terminal Block with Wire-to-Board Connectors	IC670CHS003
Thermocouple Terminal Block	IC670CHS004
Auxiliary Terminal Block with Barrier-style Terminals	IC670TBM001
Auxiliary Terminal Block with Box-style Terminals	IC670TBM002
Input Module, 120 VAC, 8 Isolated Points	IC670MDL233
Input Module, 120 VAC, 16 Grouped Points	IC670MDL240
Input Module, 16 Points, 2 groups 240 VAC	IC670MDL241
Input Module, 24 VDC, 16 Grouped Positive/Negative Points	IC670MDL640
Input Module, 48 VDC, 16 Grouped Positive/Negative Points	IC670MDL641
Input Module, 125 VDC, 16 Grouped Positive/Negative Points	IC670MDL642
Input Module, 5/12 VDC 16 Point	IC670MDL643
Input Module 12/24 VDC 16 Grouped Positive/Negative Fast Inputs	IC670MDL644
Mixed Input/Output Module 24 VDC, 10 Inputs and 6 Outputs	IC670MDD441
Input Simulator Module, Horner, 8 Points	HE670ACC100
Input Module, 30-300 VDC, Horner	HE670DIM300
Output Module, 8 Point 24VDC Electronic Short Circuit Protection	IC670MDL730
Output Module, 12/24 VDC 0.5 Amp, 16 Grouped Positive Points	IC670MDL740
Output Module, 5/12/24 VDC Negative Outputs	IC670MDL742
Output Module, 16 Point 12-120 VAC 16 Point, 0.5 Amp	IC670MDL330
Output Module, 120 VAC 2 Amp, 8 Isolated Points	IC670MDL331
Relay Output Module, 2 Amp, 6 Form A Points and 2 Isolated Form C Points	IC670MDL930
Relay Module, High Current 16 Points, Horner	HE670RLY168
Output Module, 25 Amp, 125 VDC, Horner	IC670DQM125
Analog Current Input Module, 8 Grouped Points	IC670ALG230
Analog Input Module, 16-Point Grouped	IC670ALG240
RTD Input Module	IC670ALG620
Thermocouple Input Module	IC670ALG630
Analog Input Module, Horner, +/-10 VDC, 0-10 VDC, 8 points	HE670ADC810
Isolated Analog Input Module (Voltage), Horner	HE670ADC830
Isolated Analog Input Module (Current), Horner	HE670ADC840
Analog Current/Voltage Output Module, 4 Grouped Points	IC670ALG320
Analog Current source Output Module, 8 Points	IC670ALG330
Isolated Analog Voltage Output Module, 8 Points	IC670ALG310
Isolated Analog Output Module (Voltage), Horner	HE670DAC830
Isolated Analog Output Module (Current), Horner	HE670DAC840
I/O Base Connection Cables, extra	IC670CBL001
I/O Expansion Cable, 21-inch	IC670CBL002
2 Meter Cable for Connector-style Terminal Block, connector on one end	IC670CBL003
1 Meter Cable for Connector-style Terminal Block, connectors on both ends	IC670CBL004
Mating Connectors for I/O Terminal Block IC670CHS003	IC670ACC003

Chapter 2

Installation

This chapter describes:

- Choosing and Installing the DIN Rail
- Installing an I/O Terminal Block on the DIN Rail
- Removing the I/O Terminal Block from a DIN Rail
- Installing an Auxiliary Terminal Block
- Removing an Auxiliary Terminal Block
- Protective I/O Terminal Block Labels
- Installing the Cables Between Terminal Blocks
 - Installing an I/O Expansion Cable
- Wiring for I/O Modules
 - Terminal Assignments for I/O Terminal Blocks
 - Terminal Assignments for Auxiliary Terminal Blocks
 - Power Wiring
 - Noise Immunity
 - Discrete I/O Wiring
 - Analog I/O Wiring
- Module Installation
 - Adding I/O Module Keying (optional)
 - Installing an I/O Module on the Base
 - Hot Insertion/Removal of Modules

Choosing and Installing the DIN Rail

All Field Control Terminal Blocks must be mounted on a **35mm x 7.5mm DIN rail**.

The rail must have a conductive (unpainted) finish for proper grounding.

When using multiple rail sections, be sure they are properly aligned. Center the DIN rail at least 4.25 inches (10.80 cm) from any wireway or other obstruction on the wiring side of the I/O Terminal Block. Allow more space if the wiring for I/O modules is very stiff.

For added vibration resistance, the DIN rail should be installed on a panel using screws spaced approximately 6 inches (5.24cm) apart. For maximum vibration resistance, drill holes for all terminal block mounting ears. Locations for I/O Terminal Block and Auxiliary Terminal Block mounting ears are shown at right.

After mounting the terminal block on the DIN rail, install 3/8-inch (9.525mm) #6 screws (not supplied) through the mounting ears.

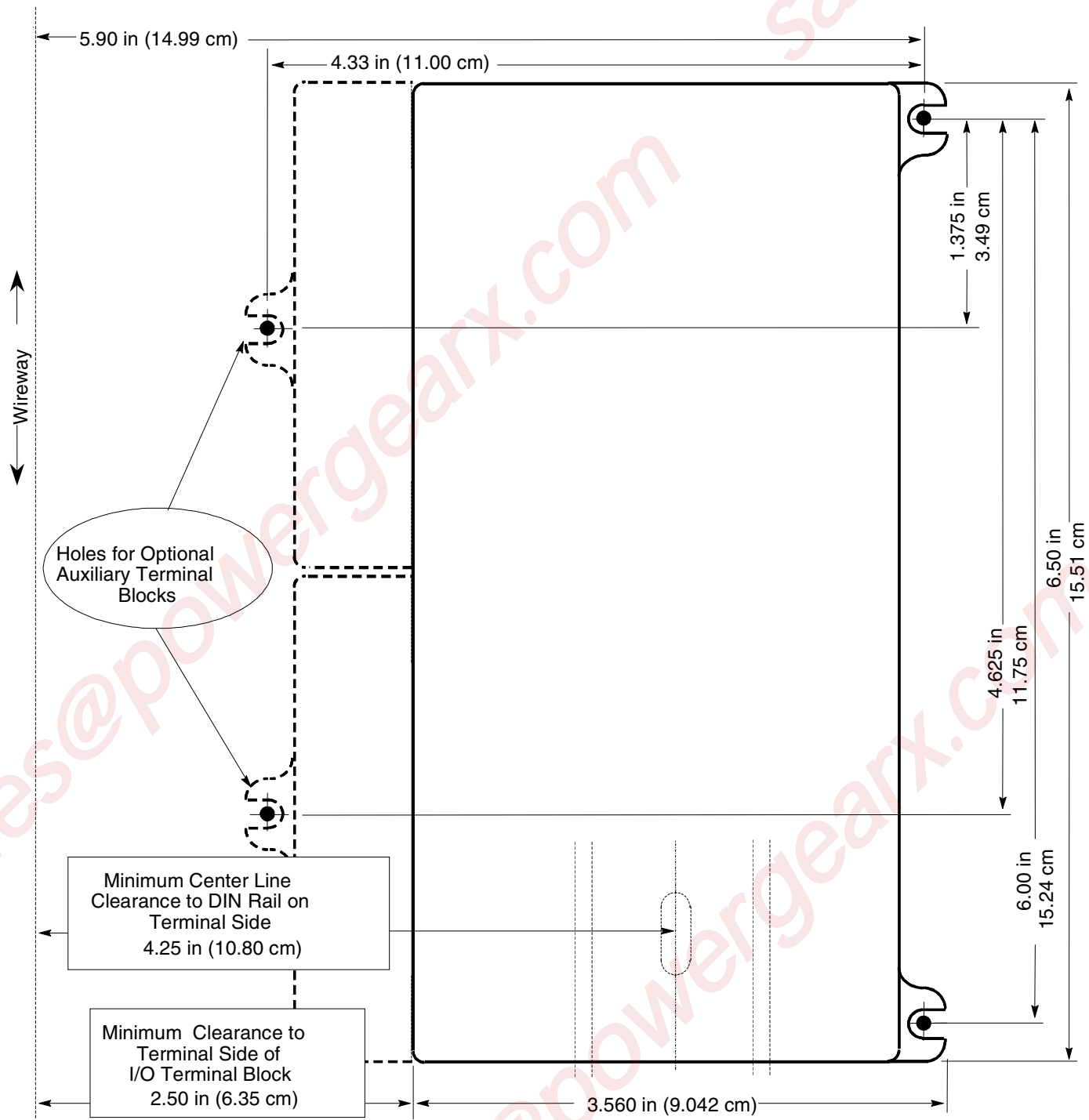

Installing an I/O Terminal Block on the DIN Rail

- Step 1. Tilt the I/O Terminal Block and position it over the rail, as shown below left, catching the rail behind the tabs in the terminal block.
- Step 2. Pivot the terminal block downward until the spring-loaded latches in the terminal block click into place.

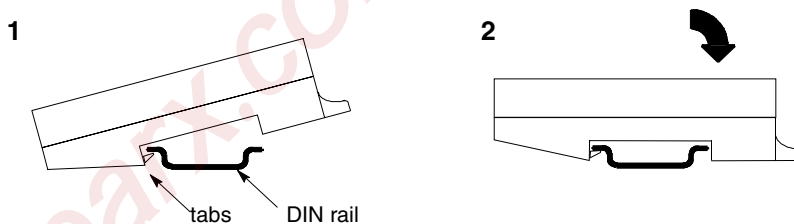

- Step 3. Tighten the DIN rail clamp screw (see below left). Recommended torque is 4 to 6-in/lbs.
- Step 4. Install Auxiliary Terminal Block(s) if needed.

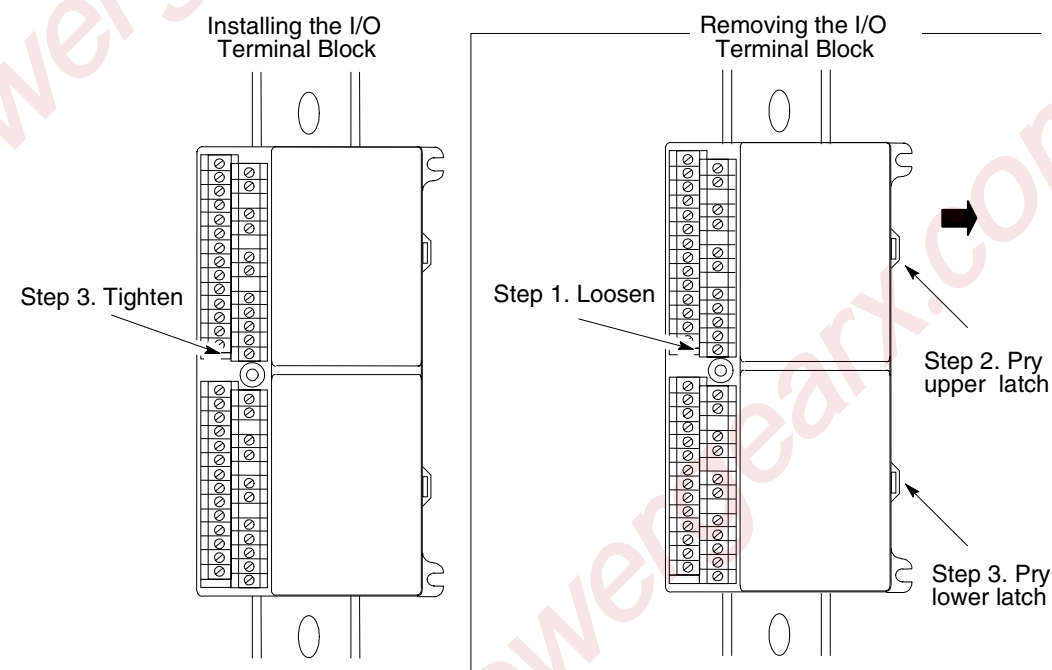

Removing the I/O Terminal Block from a DIN Rail

- Step 1. If Auxiliary Terminal Blocks have been used, they must be removed first.
- Step 2. Loosen the DIN rail clamp screw (see above right).
- Step 3. Insert a small flat-blade screwdriver into the upper latch and pry it outward. Then, pull gently on the top of the terminal block to disengage the upper latch from the rail.
- Step 4. Keep gently pulling the top of the terminal block away from the rail. Insert the screwdriver into the lower latch and pry it outward to free the terminal block.

Installing an Auxiliary Terminal Block

The I/O Terminal Block must be mounted on the DIN rail before installing an Auxiliary Terminal Block.

1. Install I/O Terminal Block

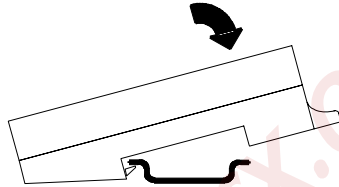

2. Install Auxiliary Terminal Block

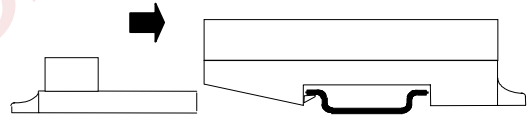

To install an Auxiliary Terminal Block, simply slide the large tabs into the corresponding slots underneath the I/O Terminal Block. Push firmly until it clicks into place.

Inserting an Auxiliary Terminal Block
(seen from underneath)

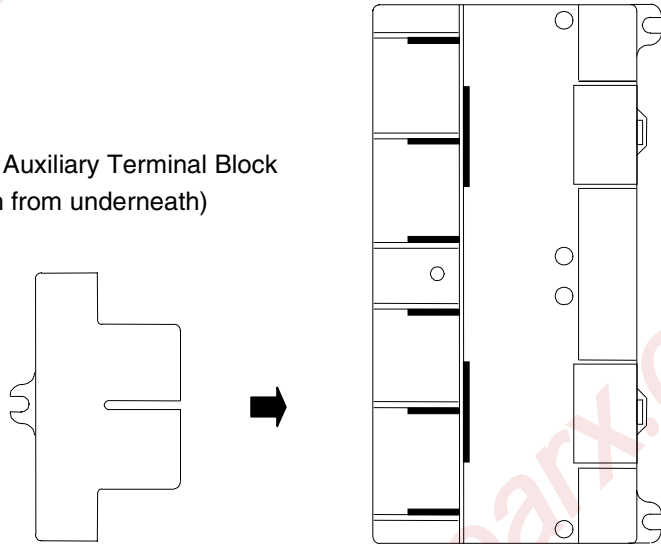

Removing an Auxiliary Terminal Block

To remove an Auxiliary Terminal Block, raise it upward then pull it out.

1. Raise Auxiliary Terminal Block Up

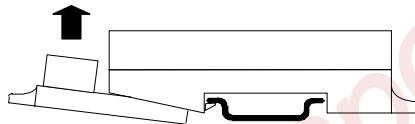

2. Remove Auxiliary Terminal Block

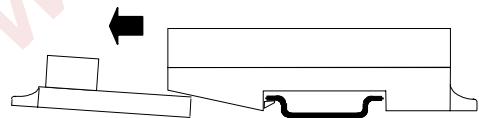

Protective I/O Terminal Block Labels

When you unpack a new I/O Terminal Block, its upper surface is covered by a pair of sturdy labels. While installing the I/O Terminal block, keep these labels in place to prevent environmental contamination of module components. Leave the protective label in place for any slot where a module is not installed.

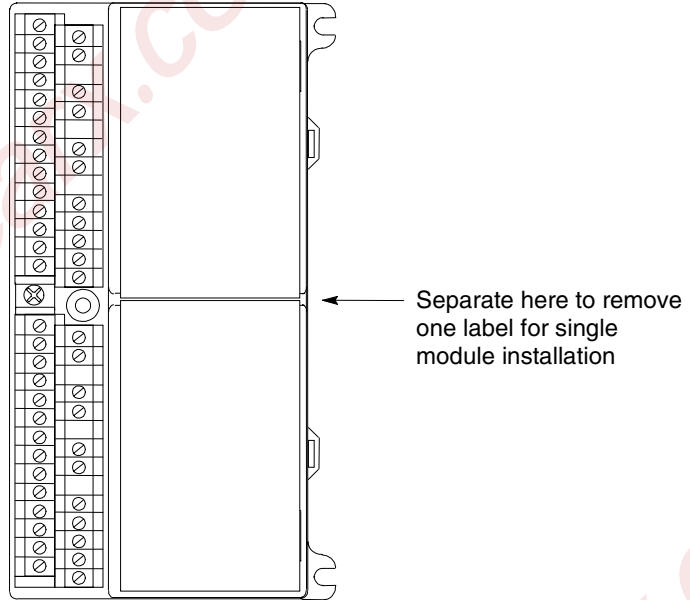

Installing the Cables Between Terminal Blocks

Before installing modules on their terminal blocks, install the connecting cable(s) between terminal blocks. A short connecting cable, illustrated below, is supplied with each I/O Terminal Block. A set of connecting cables is available as renewal part number IC670ACC001. Optional 21-inch (0.53 meter) cable (IC670CBL002) is also available (only one longer cable can be used per I/O station).

The illustration below shows the basic cable connection between a Bus Interface Unit terminal block and an I/O Terminal Block. The protective labels are still in place on the I/O Terminal Block, but the label corners have been removed to permit access to the Terminal Block cable connectors.

Make connections between I/O Terminal Blocks the same way. The connectors are keyed to assure proper installation.

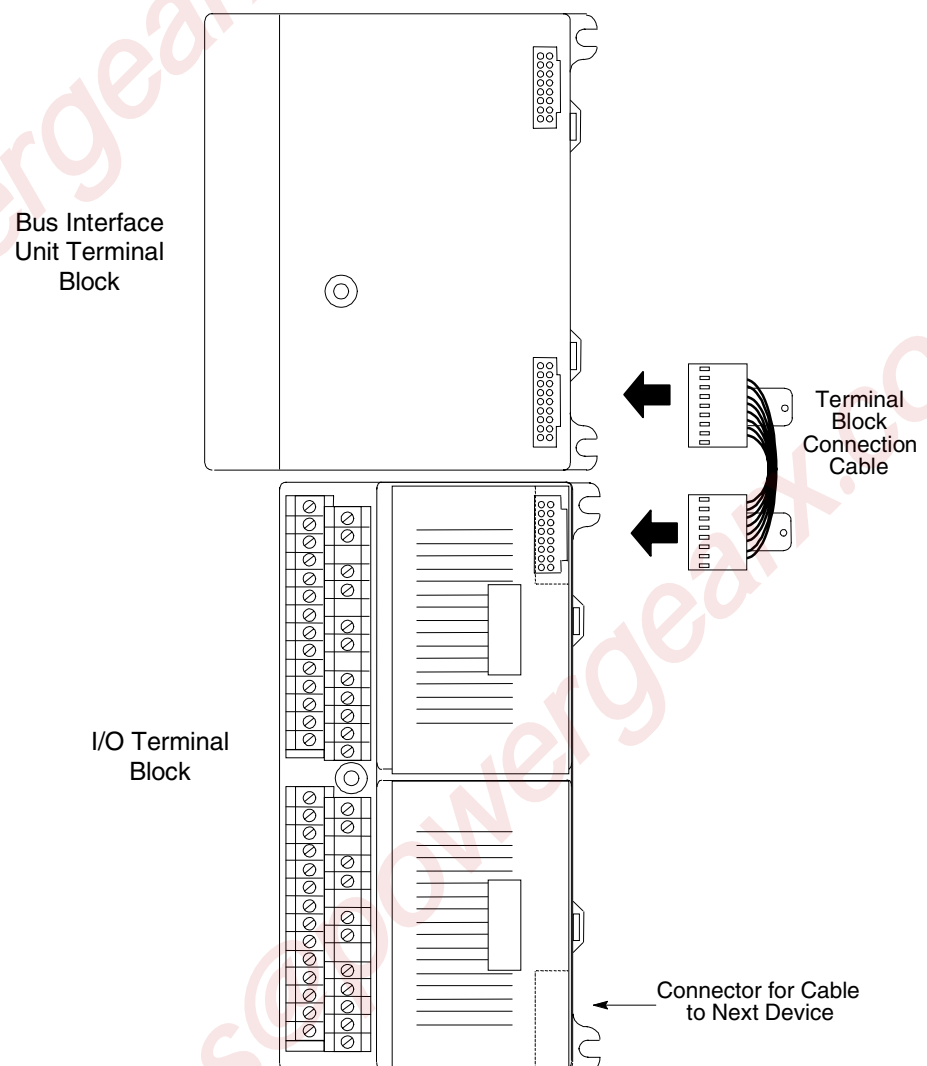

After installing the cable, be sure it is firmly seated on both connectors.

Installing an I/O Expansion Cable

The 21" (54.61 cm) I/O Expansion Cable (IC670CBL002) can be used in place of the standard inter-base cable where more space is needed between bases. Only one I/O Expansion Cable can be used per station. The remaining connections must be made using the shorter connectors supplied with the bases.

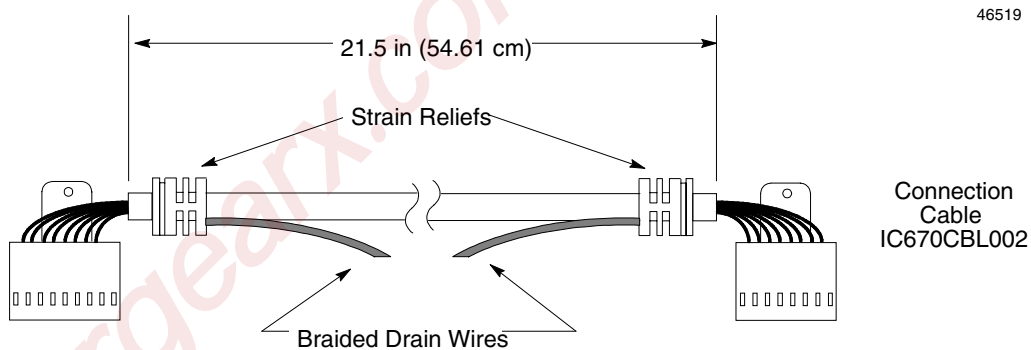

The I/O Expansion Cable can connect an I/O base with the Bus Interface Unit base or with another I/O base. The cable must be installed so that direction of data flow is consistent from one base to the next. That is, the cable would connect the “bottom” of one base with the “top” of the next base if the bases were both oriented the same way (as they must be when using the short cable).

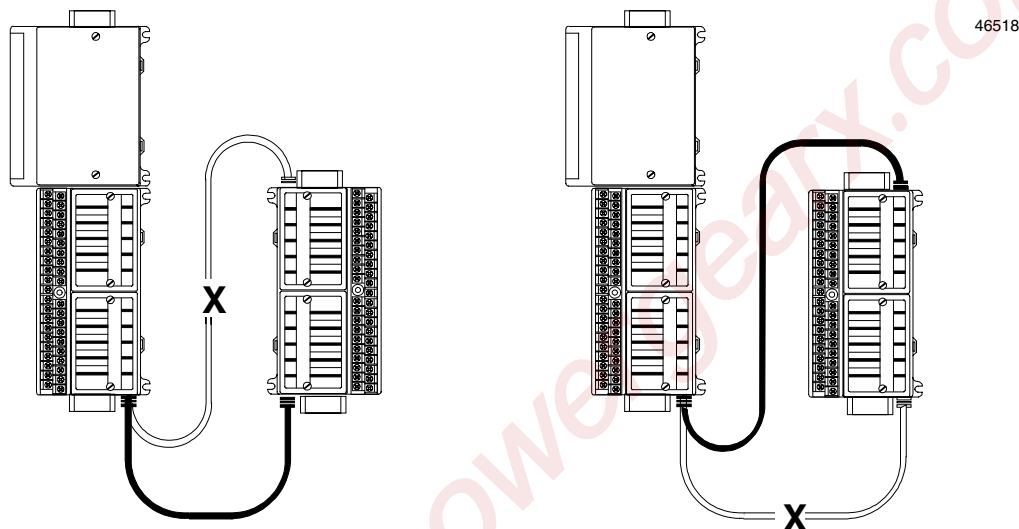

The corners of the protective labels must be removed to permit access to the Terminal Block cable connectors. The connectors are keyed to assure proper installation.

For proper noise immunity protection, connect both drain wires to chassis ground. This can be done by using a DIN rail clamp, or by placing a ring terminal on each drain wire and attaching each ring terminal to the mounting plate with a screw and star washer.

Wiring for I/O Modules

Modules are wired to I/O Terminal Blocks with the terminal styles shown below. Wiring can be completed either before or after installing I/O modules. Refer to the individual block datasheets in this manual for specific wiring details.

Terminal Assignments for I/O Terminal Blocks

The Terminal Block with box terminals (catalog number IC670CHS002 and 102) has 51 terminals, each of which accommodates one AWG #14 (avg 2.1mm^2 cross section) to AWG #22 (avg 0.36mm^2 cross section) wire, or two wires up to AWG #18 (avg. 0.86mm^2 cross section). An insulated external 5mm (0.2in) jumper such as Altech #8879 can be used to connect adjacent points. When an external jumper is used, the wire capacity is reduced from AWG #14 (2.10mm^2) to AWG #16 (1.32mm^2).

The I/O Terminal Block with barrier terminals (catalog number IC670CHS001 and 101) has 37 terminals. Each terminal can accommodate one or two wires up to AWG #14 (avg 2.1mm^2 cross section).

The I/O Terminal Block with Connectors (catalog number IC670CHS003 and 103) has two 20-pin male connectors for I/O wiring. The mating connector is Amp part number 178289-8. Any tin-plated contact in the AMP D-3000 series can be used with the connector (Amp part number 1-175217-5 for high contact force receptacle for 20-24 gauge ($0.20\text{-}0.56\text{mm}^2$) wires), 1-175218-5 for high contact force receptacle for 16-20 gauge ($0.56\text{-}1.42\text{mm}^2$)). A kit containing two mating connector housings and contacts is available as GE Fanuc part number IC670ACC003. The kit contains pins for 16-20 gauge wire. A crimping tool must be provided, and used according to the guidelines in the datasheet provided with the I/O Terminal Block with Connectors.

Each terminal block has two independent sets of terminals.

I/O Module Terminal Assignment Reference Tables

I/O Terminal Block with Box Terminals (IC670CHS002 and 102)

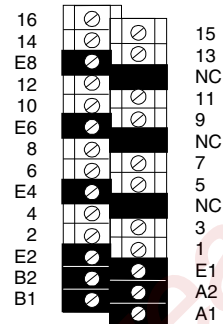

I/O Terminal Block with Barrier Terminals (IC670CHS001 and 101)

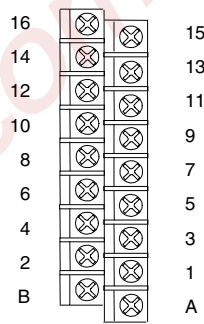

I/O Terminal Block with Wire to Board Connectors (IC670CHS003 and 103)

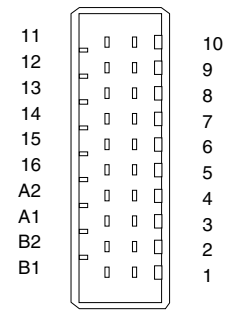

The following tables summarize terminal assignments for Field Control I/O modules.

Discrete Input Module Terminal Assignments

Terminal	Module ID (IC670.....)				
	MDL233	MDL240	MDL241	MDL640, 641, 642, 644	MDL643
A1	no connect	no connect	N 1	no connect	COM 1
A2	no connect	no connect	N 1	no connect	COM 1
B1	no connect	Neutral	N 2	DC+ or DC-	COM 2
B2	no connect	Neutral	N 2	DC+ or DC-	COM 2
E1,2,4,6,8	Common	Common	Common	Common	Common
1	Input 1			Input 1	
2	Neutral 1			Input 2	
3	Input 2			Input 3	
4	Neutral 2			Input 4	
5	Input 3			Input 5	
6	Neutral 3			Input 6	
7	Input 4			Input 7	
8	Neutral 4			Input 8	
9	Input 5			Input 9	
10	Neutral 5			Input 10	
11	Input 6			Input 11	
12	Neutral 6			Input 12	
13	Input 7			Input 13	
14	Neutral 7			Input 14	
15	Input 8			Input 15	
16	Neutral 8			Input 16	

Discrete Output and Mixed I/O Module Terminal Assignments

Terminal	Module ID (IC670.....)					
	MDL331	MDL330	MDL740, 742	MDL730	MDL930	MDD441 (mixed)
A1	no connect	H	DC+	DC+	Com 1C	DC+
A2	no connect	H	DC+	DC+	Com 1C	DC+
B1	no connect	no connect	DC-	DC-	Com 2C	DC-
B2	no connect	no connect	DC-	DC-	Com 2C	DC-
E1,2,4,6,8	Common	Common	Common	Common	Common	Common
1	Output 1	Output 1	Output 1	Output 1	N. Clos. 1C	Output 1
2	H 1	Output 2	Output 2	Return 1	N. Clos 2C	Output 2
3	Output 2	Output 3	Output 3	Output 2	N. Open 1C	Output 3
4	no connect	Output 4	Output 4	Return 2	N. Open 2C	Output 4
5	Output 3	Output 5	Output 5	Output 3	N. Open 3A	Output 5
6	H 2	Output 6	Output 6	Return 3	Com 3A	Output 6
7	Output 4	Output 7	Output 7	Output 4	N. Open 4A	Input 1
8	no connect	Output 8	Output 8	Return 4	Com 4A	Input 2
9	Output 5	Output 9	Output 9	Output 5	N. Open 5A	Input 3
10	H 3	Output 10	Output 10	Return 5	Com 5A	Input 4
11	Output 6	Output 11	Output 11	Output 6	N. Open 6A	Input 5
12	no connect	Output 12	Output 12	Return 6	Com 6A	Input 6
13	Output 7	Output 13	Output 13	Output 7	N. Open 7A	Input 7
14	H 4	Output 14	Output 14	Return 7	Com 7A	Input 8
15	Output 8	Output 15	Output 15	Output 8	N. Open 8A	Input 9
16	no connect	Output 16	Output 16	Return 8	Com 8A	Input 10

Analog Module Terminal Assignments

Terminal	Module ID (IC670.....)						
	ALG230	ALG240	ALG310	ALG320	ALG330	ALG620	ALG630
A1	DC+	not used	+24V	DC+	DC+	not used	Thermistor (+)
A2	DC+	not used	+24V	DC+	DC+	not used	Thermistor (+)
B1	DC-	DC- (return)	Return	DC-	DC-	not used	Thermistor (-)
B2	DC-	DC- (return)	Return	DC-	DC-	not used	Thermistor (-)
E1,2,4,6,8	Common	Common	Common	Common	Common	not used	Common
1	Input 1	Input 1	Return A	V 1	Output 1	Return 1	Input 1 (-)
2	+24V Out	Input 2	Return A	Jmp 1	Return 1	Return 2	Input 2 (-)
3	Input 2	Input 3	Output A1	I 1	Output 2	Input (-) 1	Input 1 (+)
4	+24V Out	Input 4	Output A2	Ret 1	Return 2	Input (-) 2	Input 2 (+)
5	Input 3	Input 5	Output A3	V 2	Output 3	Input (+) 1	Input 3 (-)
6	+24V Out	Input 6	Output A4	Jmp 2	Return 3	Input (+) 2	Input 4 (-)
7	Input 4	Input 7	Return A	I 2	Output 4	Source 1	Input 3 (+)
8	+24V Out	Input 8	Return A	Ret 2	Return 4	Source 2	Input 4 (+)
9	Input 5	Input 9	Return B	V 3	Output 5	Return 3	Input 5 (-)
10	+24V Out	Input 10	Return B	Jmp 3	Return 5	Return 4	Input 6 (-)
11	Input 6	Input 11	Output B1	I 3	Output 6	Input (-) 3	Input 5 (+)
12	+24V Out	Input 12	Output B2	Ret 3	Return 6	Input (-) 4	Input 6 (+)
13	Input 7	Input 13	Output B3	V 4	Output 7	Input (+) 3	Input 7 (-)
14	+24V Out	Input 14	Output B4	Jmp 4	Return 7	Input (+) 4	Input 8 (-)
15	Input 8	Input 15	Return B	I 4	Output 8	Source 3	Input 7 (+)
16	+24V Out	Input 16	Return B	Ret 4	Return 8	Source 4	Input 8 (+)

Terminal Assignments for Auxiliary Terminal Blocks

Auxiliary Terminal Blocks which have all terminals internally connected together can be used for extra wiring terminals for I/O modules. They can also be used for extra ground, return, or common connections.

The Auxiliary Terminal Block with box terminals (catalog number IC670TBM002) has 13 terminals, each of which accommodates one AWG #14 (avg 2.1mm² cross section) to AWG #22 (avg 0.36mm² cross section) wire, or two wires up to AWG #18 (avg. 0.86mm² cross section). The Auxiliary Terminal Block with barrier terminals (catalog number IC670TBM001) has nine terminals, each of which can accommodate one or two wires up to AWG #14 (avg 2.1mm² cross section).

**Auxiliary Terminal Block with Box Terminals
(IC670TBM002)**

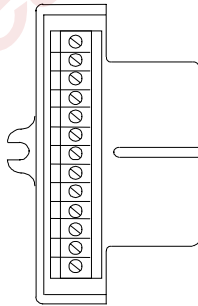

**Auxiliary Terminal Block with Barrier Terminals
(IC670TBM001)**

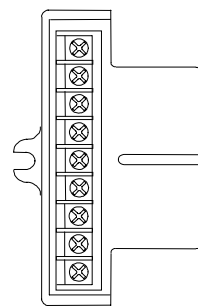

Power Wiring

All Field Control I/O modules require field-side power for their I/O devices. Power supply connections can easily be “daisy-chained” between modules with similar power requirements. There is a 10 Amp maximum limit on any one screw. Alternatively, separate supplies can be used on any combination of modules to provide isolation as needed.

The location of the power connection on an I/O module depends on the module type. For information on power connection to a specific type of module, refer to its individual module datasheet.

Power Wiring for Hot Insertion/Removal

For Hot Insertion/Removal of modules, power must be switched off to the module being inserted or removed. A means of removing power to the module should be provided during installation.

Noise Immunity

Good wiring practices are the foundation for reliable and predictable system operation.

The electrical environmental standards listed in chapter 1 should be used as benchmarks. Uncontrolled combinational effects in a real installation, higher levels of noise, or sources of noise with different properties from those in the Standard can still cause problems. Therefore, it is important to follow prudent wiring and suppression practices in the installation.

Wiring external to equipment and in cable trays should be separated following accepted practices.

Discrete I/O Wiring

Discrete switches and loads are usually two-wire devices. General practice is to terminate both wires at the control panel. One side of discrete devices is usually a common supply or return tie point. Field Control I/O Terminal Block and Auxiliary Terminal Block tie point connections provide sufficient locations to accomplish this.

Suppression at the Output Load

Most solid state controls include load suppression within the output drive. AC solid state relays and proximity switches turn off at low currents with some internal suppression. DC devices usually specify suppression if not included with the device. Additional suppression is required if:

1. The stored load energy to be dissipated exceeds the rating of the module's output suppressor during the turn-off discharge time.
2. A mechanical contact is used in series with a driven output coil. Install additional suppression such as a series resistor-capacitor snubber to counteract electrical noise that occurs when the coil is switched by the external contact instead of the module.

Resistor-capacitor suppressors are preferred for low-current high-inductance loads that generate a high rate of change in voltage (dv/dt). High power loads beyond the capacity of RCs use voltage clamping devices such as MOVs, which are usually available from the manufacturer of the device. Resistor-capacitor suppressors are also preferred to MOVs because they reduce EMI in addition to absorbing load energy.

In general, the capacitor for an RC snubber should be the same value in microfarads as the coil current in amperes, with the voltage rating at least twice the peak supply voltage. The resistor is usually equal to the DC resistance of the coil. With DC coils, the capacitor is usually replaced with a “flyback” diode oriented with the anode to the negative terminal of the coil. The resistor helps maintain a fast dropout of the device; it can be eliminated if this is not of concern.

Most control and contactor manufacturers make suppressor accessories that can be conveniently mounted on their devices. The following types are available from GE General Purpose Control, Bloomington, IL:

Type	Voltage	Part Number
RC	110 - 180 VAC	CR4XS1B
	380 - 480 VAC	CR4XS1C
	24 - 48 VAC	CR4ZS1J
Diode	12 - 250 VDC	CR4XS2P
Varistor	24 VDC	CR4XS3L
	36 - 48 VDC	CR4XS3M
	110 - 150 VDC	CR4XS3N
	220 - 250 VDC	CR4XS3P

For NEMA size 0 - 6 contactors: CR305X146C

Consult other manufacturers for recommendations of equivalent suppressors for their devices. Discrete components can also be used as discussed earlier. Phoenix Contact Inc., Weidmuller Inc.,

and other manufacturers make DIN rail mounted suppressors for both load snubbing and line surge protection.

If noise is generated by a protective contact that operates only in abnormal conditions, not as part of the normal machine cycle, the best way to handle possible control shutdown which may occur during machine faults depends on the application. Normally, re-cycling module control power will enable resumption of operation.

The problem with mixing control and power-level wiring is that while high fields due to steady-state voltage and currents are seldom a problem, high-level switching transients can couple through the wiring. The source can be difficult to identify, and nearly impossible to suppress due to the high power levels involved. The amount of coupling depends on the length and proximity of the wires. Wires that cause a problem because of contact within a conduit may be no problem when installed separated by a few inches in a cable tray. The electrical wiring and safety codes specify separation by voltage and/or power levels for shock and flammability hazards, but do not address interference. Most PLC I/O should be treated as low-power remote control; example USA National Electric Code Article 725, or Canadian Electric Code Section 16. The modest segregation required is likely sufficient to reduce the interference to the typical environmental levels used by the noise Standards.

A documentation of PLC wiring practices is contained in part 4 of the International Standard for PLCs IEC1131-4.

Analog I/O Wiring

Analog I/O points may require 2 to 4 wires per point, not including terminations for shielded wire. Signal-carrying wires may have varying degrees of isolation from the associated analog power supply, which itself may be floating or grounded.

The various types of analog points also have different requirements for power, ground, and common connection. Extra care is needed to prevent wiring errors.

Module Installation

Caution

Electrostatic discharge can damage an I/O Module when the module is not installed on an I/O Terminal Block. Always observe good ESD protection practices when handling an un-installed module.

If the protective label is still in place on the I/O Terminal Block, remove it before attempting to install an I/O Module.

Adding I/O Module Keying (optional)

Each type of I/O module is uniquely slotted. (Optional) to assure installation of the correct module type in a specific position, insert the key clips provided into the appropriate lettered slots in the I/O Terminal Block (after removing the protective label).

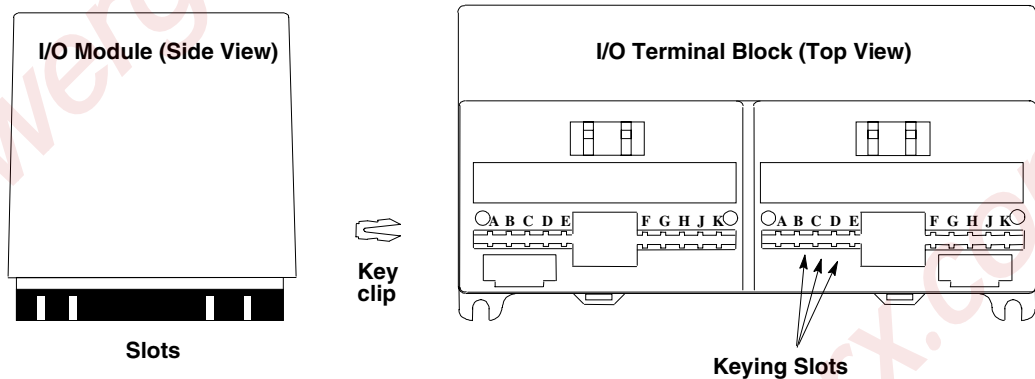

The following table shows the keying locations of various types of I/O modules.

Module ID: IC670...	Keying Locations										
	A	B	C	D	E	F	G	H	J	K	
MDL240		x			x	x	x				
MDL241			x		x	x			x		
MDL330, MDL331		x			x	x		x			
MDL640, MDL644, MDD441	x		x				x	x			
MDL641		x		x			x	x			
MDL642	x				x		x	x			
MDL643	x	x					x	x			
MDL730, MDL740, ALG320, ALG330	x		x						x	x	
MDL233		x			x	x			x		
MDL742	x	x						x		x	
MDL930			x	x	x	x	x	x			
ALG230, ALG240	x			x			x	x			
ALG630, ALG620	x			x				x	x		
ALG310	x			x					x	x	

Installing an I/O Module on the Base

1. Before installing a new module, remove the cable slot knockout(s) wherever the module would cover the terminal board connecting cables. The knockout can be removed with pliers, or by pressing *out* from inside the module housing.
2. To install an I/O module, position the module so that the cable slot in the module housing is over the connecting cable.

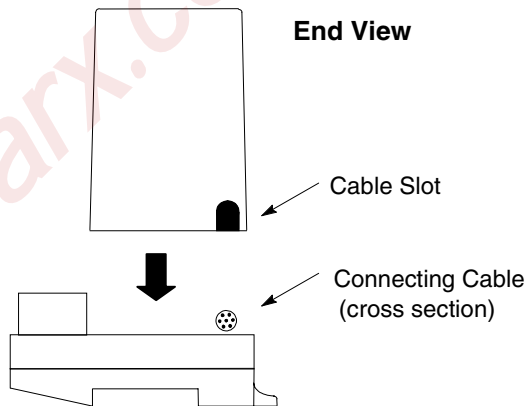

When installing a module over a 21 inch (54-cm) I/O Expansion Cable, fit the edge of the module housing into the groove in the cable strain relief.

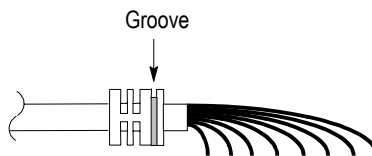

3. Press the module down firmly.
4. If you feel resistance, remove the module and check the keying (if keying has been used). Also be sure the connecting cable is in the cable slot properly.
5. After placing an I/O module onto the base, tighten its bolts to secure it. Maximum recommended torque is 9 in/lbs.

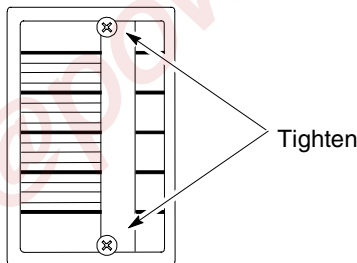

Hot Insertion/Removal of Modules

Bus Interface Units IC670GBI002(F) and IC670GBI102A or later support Hot Insertion/Removal of modules in the I/O Station.

Hot Insertion/Removal means that modules can be removed and replaced while I/O Station power is applied without affecting the BIU or other modules in the I/O Station. Separate I/O module power must be switched off to the module being inserted or removed.

Hot Insertion/Removal requires the use of specific modules and I/O terminal blocks:

- **I/O modules** having catalog number suffix J or above. These modules have a projecting alignment tab that fits into a corresponding alignment tab on I/O Terminal Blocks listed below. Note that modules with this tab can also be installed on older I/O Terminal Blocks that do not have mating alignment tabs. However, Hot Insertion/Removal are not supported in such an installation.
- **I/O Terminal Blocks** IC670CHS101, 102, or 103. These I/O Terminal Blocks have projecting alignment tabs designed to facilitate Hot Insertion/Removal of modules. Modules that are earlier than revision J cannot be mounted on these terminal blocks.

I/O Terminal Blocks IC670CHS001, 002, and 003, which lack alignment tabs, do not support Hot Insertion/Removal of modules. With these terminal blocks, I/O Station power should be off when installing or removing modules.

Mixing IC670CHS10x terminal blocks with IC670CHS00x terminal blocks in the same I/O station is not recommended.

Faults Reported During Hot Insertion/Removal

When using the recommended equipment listed above, Hot Insertion/Removal may cause the expected fault reports related to the loss of or addition of the module and its I/O circuits. These faults should be cleared in the normal manner. However, Hot Insertion/Removal of a rev. J or later module will NOT cause Configuration Mismatch errors that in some types of systems can shut down the controller.

I/O Module Data During Hot Insertion/Removal

As mentioned, separate I/O module power must be turned off for Hot Insertion/Removal. When the module is installed and power is reapplied, module data will quickly return to normal. For intelligent I/O modules, there may be a delay of a few seconds while the module goes through its powerup sequence.

Hot Insertion/Removal for a Micro Field Processor

A Micro Field Processor that is revision J or later may be removed/inserted as described above. Note, however, that although the Micro Field Processor will start functioning upon reinstallation, the MFP's application program must be reloaded. I/O data controlled by the Micro Field Processor will be incorrect until that has been done. (The configuration of the Micro Field Processor is not affected by Hot Insertion/Removal).

Hot Insertion/Removal Not Permitted in Hazardous Locations

In hazardous locations, I/O Station power must be turned off before inserting/removing module. Failure to observe this precaution may result in personal injury, system malfunction and/or damage to the equipment.

Warnings

Explosion hazard. When in hazardous locations, turn off power before replacing or wiring modules. Do not remove or insert external modules with power applied. Personal injury, system malfunction and/or damage to the equipment may occur.

In non-hazardous areas, for personal safety, field power should be off while removing or inserting a high-voltage I/O module. Avoid contact with module wiring and with the exposed connectors on the I/O Terminal Block.

Equipment labeled with reference to Class I, Groups A, B, C, and D, Div. 2 hazardous locations is suitable for use only in non-hazardous locations or in Class I, Div. 2, Groups A, B, C, and D locations.

Explosion hazard: Substitution of components may impair suitability for Class I, Division 2.

Chapter 3

120VAC Isolated Discrete Input Module IC670MDL233

The 120VAC Isolated Input Module (IC670MDL233) provides 8 isolated discrete inputs.

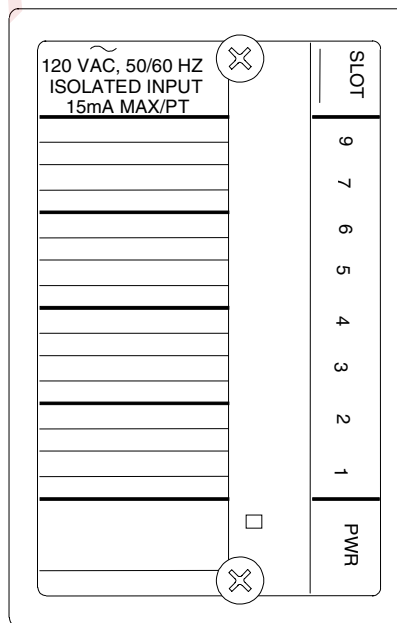

Power Sources

The module receives power from the Bus Interface Unit for its own operation.

An external 120VAC supply is needed to power the input devices. Module inputs respond to voltage levels from 0 VAC to 132 VAC.

LEDs

Individual LEDs, visible through the transparent portion of the module top, indicate the on/off status of each input. The PWR LED is on when backplane power is present.

Host Interface

Intelligent processing for this module is performed by the Bus Interface Unit or elsewhere in the system. This includes configuring features such as input defaults and fault reporting. The module has 8 bits (one byte) of discrete input data. A Bus Interface Unit is required to provide this input data to the host and/or local processor.

Module Operation

A network of resistors and capacitors establishes input thresholds and provides input filtering. Optoisolators provide isolation between the field inputs and the module's logic components. Data from all 8 inputs is placed into a data buffer. The module's circuit LEDs show the current states of the 8 inputs in this data buffer.

A parallel-to-serial converter change input data from the data buffer into the serial format needed by the Bus Interface Unit.

After checking the Board ID and verifying that the module is receiving appropriate logic power from the Bus Interface Unit (which is reflected by the state of the module's Power LED), the Bus Interface Unit then reads the filtered, converted input data.

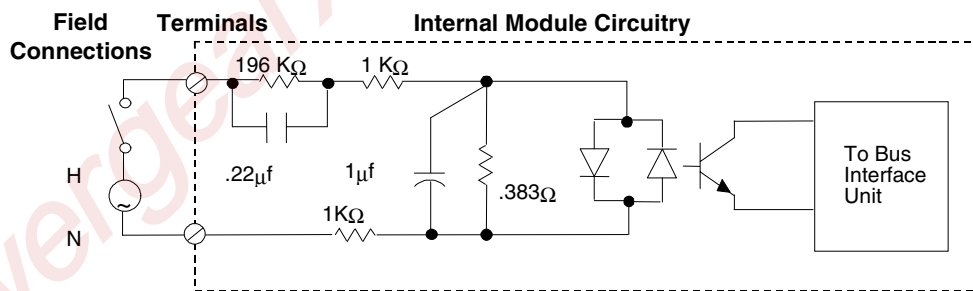

Module Specifications

Module Characteristics	
Rated Voltage	120 VAC
Input Voltage Range	0-132 VAC (47-63 Hz)
User Input Current	13 mA (typical) per point @ rated voltage
Indicators	1 LED per point shows individual point status PWR LED indicates backplane power is present
Isolation: User input to logic, user input to frame ground.	250 VAC continuous, 1500 VAC for 1 minute.
Point to point	300 VAC continuous
Current Drawn from Bus Interface Unit Power Supply	40 mA maximum
Input Characteristics	
Input Impedance	10K typical (reactive)
On state voltage	70 VAC to 120 VAC
Off state voltage	0 VAC to 20 VAC
On state Current	5mA to 15mA
Off state Current	0mA to 2.5mA
On response time	10ms typical, 20 ms maximum
Off response time	20ms typical, 40 ms maximum

Keying Locations

Optional keying locations for the 120VAC Isolated Input Module are shown below.

Keying Locations									
A	B	C	D	E	F	G	H	J	K
	x			x	x			x	

Field Wiring

I/O Terminal Block wiring assignments for this module are shown below.

The Terminal Block with box terminals has 25 terminals for each module, each of which accommodates one AWG #14 (avg 2.1mm² cross section) to AWG #22 (avg 0.36mm² cross section) wire, or two wires up to AWG #18 (avg. 0.86mm² cross section). When an external jumper is used, the wire capacity is reduced from AWG #14 (2.10mm²) to AWG #16 (1.32mm²).

The I/O Terminal Block with barrier terminals has 18 terminals per module. Each terminal can accommodate one or two wires up to AWG #14 (avg 2.1mm² cross section).

The I/O Terminal Block with Connectors has one 20-pin male connector per module. The mating connector is Amp part number 178289-8. Any tin-plated contact in the AMP D-3000 series can be used with the connector (Amp part number 1-175217-5 for high contact force receptacle for 20-24 gauge (0.20-0.56mm²) wires), 1-175218-5 for high contact force receptacle for 16-20 gauge (0.56-1.42mm²).

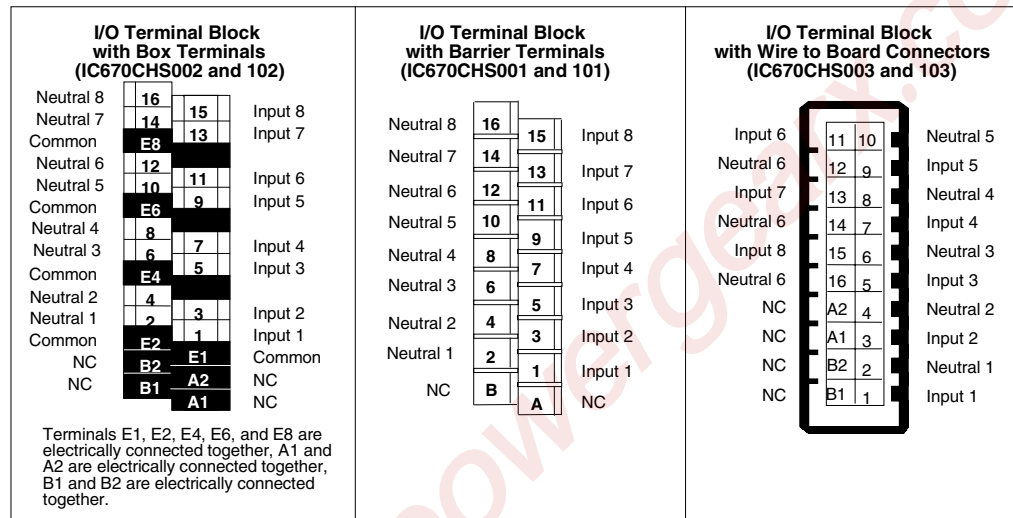

Wiring Examples with Auxiliary Terminal Blocks

If the module is installed on an I/O Terminal Block with Barrier Terminals, an Auxiliary Terminal Block can be used to provide additional wiring terminals. For the I/O Terminal Block with Wire to Board Connectors, external connection points are usually preferred, although an Auxiliary Terminal Block can be used.

Auxiliary Terminal Blocks have all terminals connected together internally. The Auxiliary Terminal Block with box terminals has 13 terminals; each accommodates one AWG #14 (avg 2.1mm² cross section) to AWG #22 (avg 0.36mm² cross section) wire, or two wires up to AWG #18 (avg. 0.86mm² cross section). The Auxiliary Terminal Block with barrier terminals has nine terminals; each can accommodate one or two wires up to AWG #14 (avg 2.1mm² cross section).

The following illustration shows how an optional Auxiliary Terminal Block with Box Terminals can be used for power connections when installing this module on an I/O Terminal Block with Box Terminals.

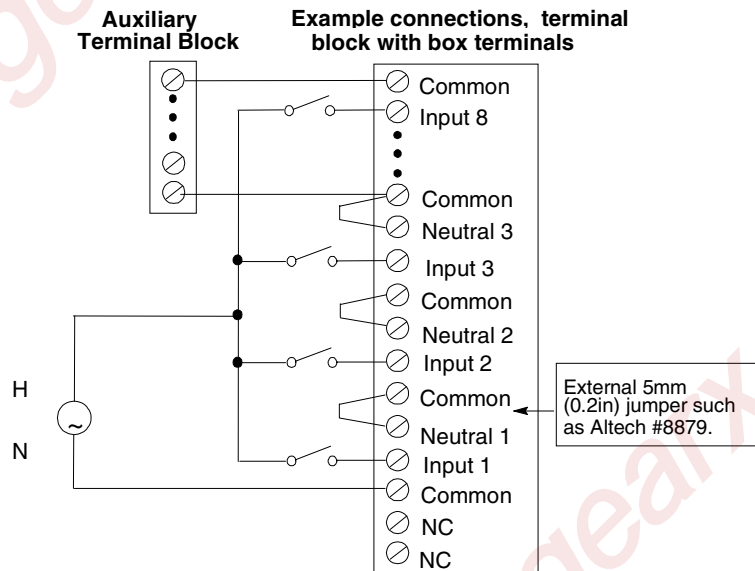

For an I/O Terminal Block with Barrier Terminals or an I/O Terminal Block with Wire to Board Connectors, an Auxiliary Terminal Block with Barrier Terminals might be connected as shown in the following example.

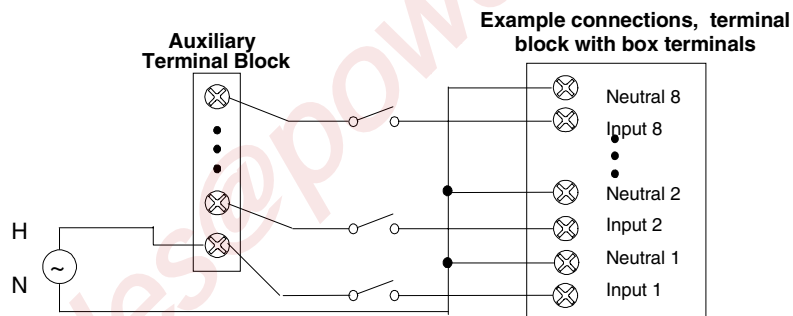

Chapter 4

120VAC Grouped Discrete Input Module IC670MDL240

The 120VAC Grouped Input Module (IC670MDL240) provides a single group of 16 discrete inputs.

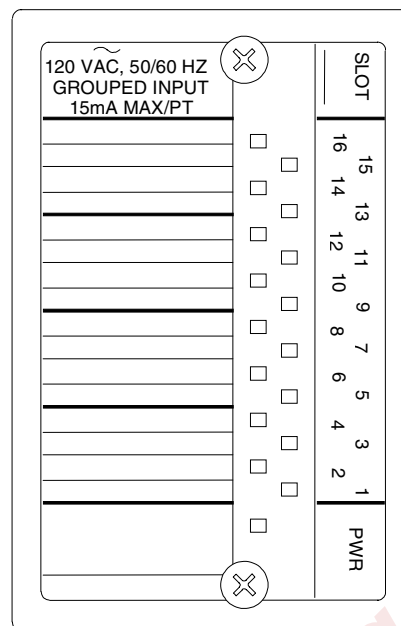

Power Sources

The module receives power from the Bus Interface Unit for its own operation.

An external 120VAC supply is needed to power the input devices. Module inputs respond to voltage levels from 0 VAC to 132 VAC.

LEDs

Individual LEDs, visible through the transparent portion of the module top, indicate the on/off status of each input. The PWR LED is on when backplane power is present.

Host Interface

Intelligent processing for this module is performed by the Bus Interface Unit or elsewhere in the system. This includes configuring features such as input defaults and fault reporting. The module has 16 bits (two bytes) of discrete input data. A Bus Interface Unit is required to provide this input data to the host and/or local processor.

Module Operation

A network of resistors and capacitors establishes input thresholds and provides input filtering. Optoisolators provide isolation between the field inputs and the module's logic components. Data from all 16 inputs is placed into a data buffer. The module's circuit LEDs show the current states of the 16 inputs in this data buffer.

Parallel-to-serial converters change input data from the data buffer into the serial format needed by the Bus Interface Unit.

After checking the Board ID and verifying that the module is receiving appropriate logic power from the Bus Interface Unit (which is reflected by the state of the module's Power LED), the Bus Interface Unit then reads the filtered, converted input data.

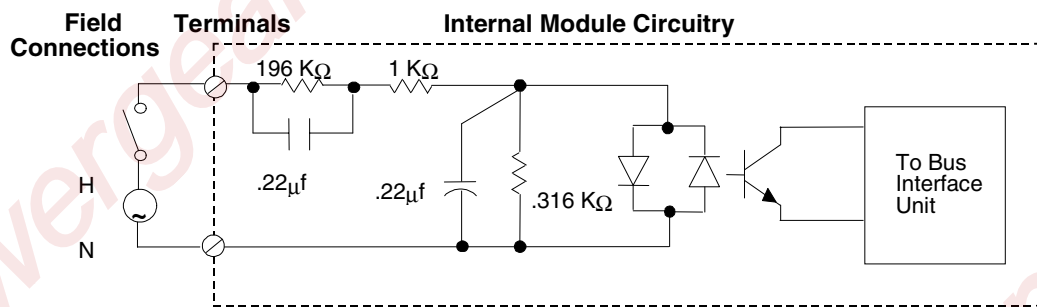

Module Specifications

Module Characteristics	
Rated Voltage	120 VAC
Input Voltage Range	0-132 VAC (47-63 Hz)
User Input Current	15 mA per point @ 120 VAC
Indicators	1 LED per point shows individual point status PWR LED indicates backplane power is present
Isolation: User input to logic, user input to frame ground, group to group	250 VAC continuous, 1500 VAC for 1 minute. No isolation between individual points in a group.
Current Drawn from Bus Interface Unit Power Supply	77 mA maximum
Input Characteristics	
Input Impedance	8.6K typical (reactive)
On state voltage	70 VAC to 120 VAC
Off state voltage	0 VAC to 20 VAC
On state Current	5mA to 15mA
Off state Current	0mA to 2.5mA
On response time	12ms typical, 20 ms maximum
Off response time	25ms typical, 40 ms maximum

Keying Locations

Optional keying locations for the 120VAC Grouped Input Module are shown below.

Keying Locations									
A	B	C	D	E	F	G	H	J	K
	x			x		x	x		

Field Wiring

I/O Terminal Block wiring assignments for this module are shown below.

The Terminal Block with box terminals has 25 terminals for each module, each of which accommodates one AWG #14 (avg 2.1mm² cross section) to AWG #22 (avg 0.36mm² cross section) wire, or two wires up to AWG #18 (avg. 0.86mm² cross section). When an external jumper is used, the wire capacity is reduced from AWG #14 (2.10mm²) to AWG #16 (1.32mm²).

The I/O Terminal Block with barrier terminals has 18 terminals per module. Each terminal can accommodate one or two wires up to AWG #14 (avg 2.1mm² cross section).

The I/O Terminal Block with Connectors has one 20-pin male connector per module. The mating connector is Amp part number 178289-8. Any tin-plated contact in the AMP D-3000 series can be used with the connector (Amp part number 1-175217-5 for high contact force receptacle for 20-24 gauge (0.20-0.56mm²) wires), 1-175218-5 for high contact force receptacle for 16-20 gauge (0.56-1.42mm²)).

Connection to the A terminals is optional. They can be used as shown on the next page.

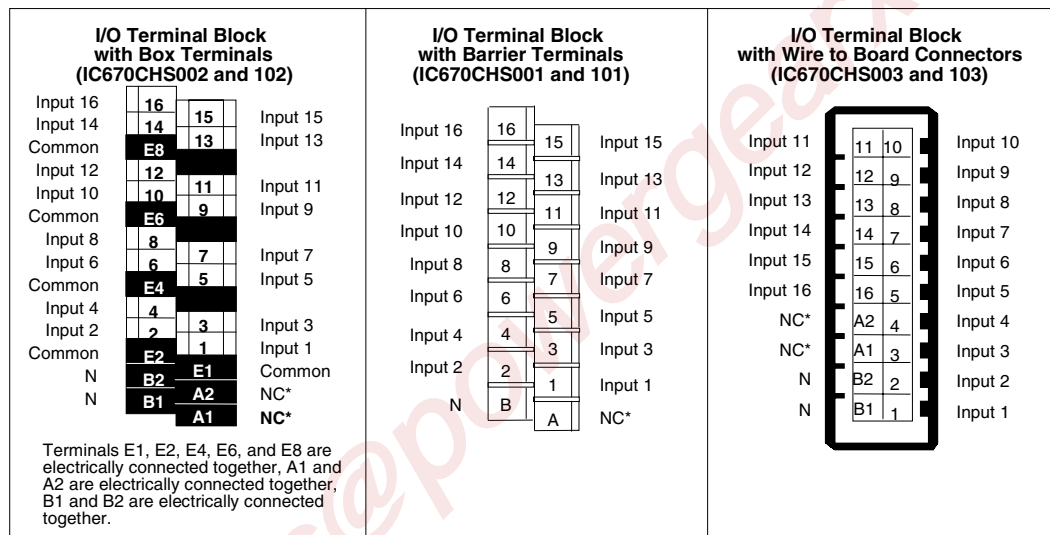

Wiring Examples with Auxiliary Terminal Blocks

If the module is installed on an I/O Terminal Block with Barrier Terminals, an Auxiliary Terminal Block can be used to provide additional wiring terminals. For the I/O Terminal Block with Wire to Board Connectors, external connection points are usually preferred, although an Auxiliary Terminal Block can be used.

Auxiliary Terminal Blocks have all terminals connected together internally. The Auxiliary Terminal Block with box terminals has 13 terminals, each of which accommodates one AWG #14 (avg 2.1mm² cross section) to AWG #22 (avg 0.36mm² cross section) wire, or two wires up to AWG #18 (avg. 0.86mm² cross section). The Auxiliary Terminal Block with barrier terminals has nine terminals, each of which can accommodate one or two wires up to AWG #14 (avg 2.1mm² cross section).

The following illustration shows how an optional Auxiliary Terminal Block with Box Terminals can be used for power connections when installing this module on an I/O Terminal Block with Box Terminals.

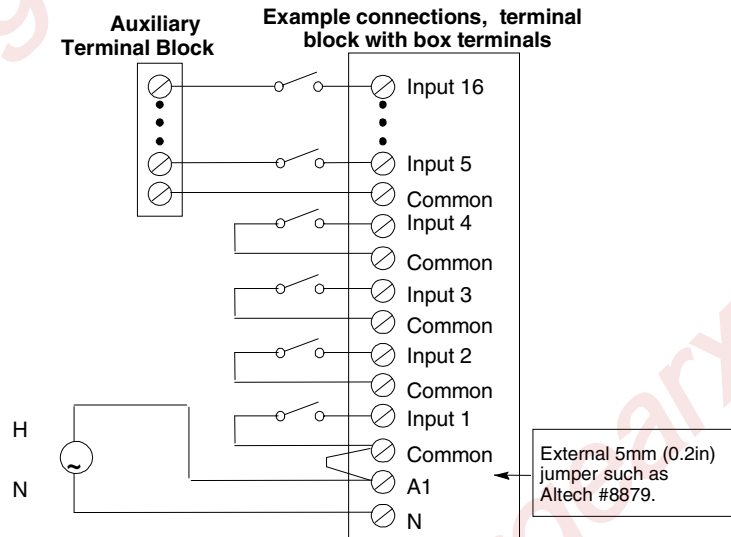

For an I/O Terminal Block with Barrier Terminals or an I/O Terminal Block with Wire to Board Connectors, an Auxiliary Terminal Block with Barrier Terminals might be connected as shown in the following example.

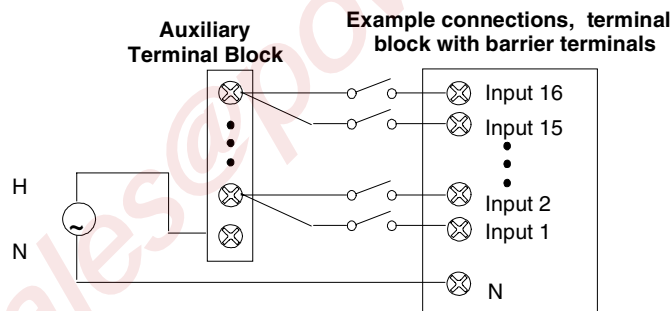

Chapter 5

240VAC Discrete Input Module IC670MDL241

The 240VAC Grouped Input Module (IC670MDL241) provides a single group of 16 discrete inputs.

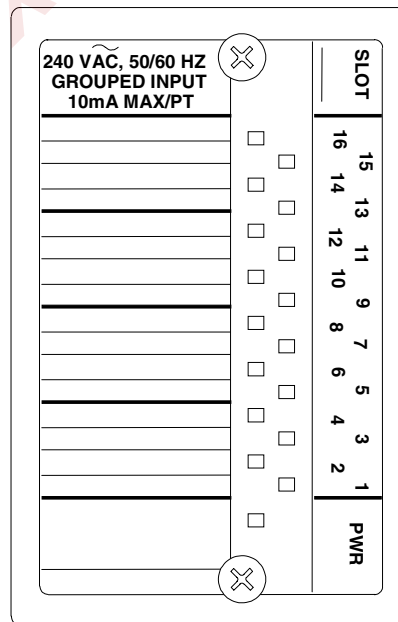

Power Sources

The power that runs the module itself comes from the power supply in the Bus Interface Unit.

A separate external 240VAC supply is needed to power each isolated group of input devices. Module inputs respond to voltage levels from 0 VAC to 265 VAC.

LEDs

Individual logic-side LEDs, visible through the transparent portion of the module top, indicate the on/off status of each input. The PWR LED is on when field and backplane power are present.

Host Interface

Intelligent processing for this module is performed by the Bus Interface Unit or elsewhere in the system. This includes configuring features such as input defaults and fault reporting. The module has 8 bits (one byte) of discrete input data. A Bus Interface Unit is required to provide this input data to the host and/or local processor.

Module Operation

A network of resistors and capacitors establishes input thresholds and provides input filtering. Optoisolators provide isolation between the field inputs and the module's logic components. Data from all 16 inputs is placed into a data buffer. The module's circuit LEDs show the current states of the 16 inputs in this data buffer.

Parallel-to-serial converters change input data from the data buffer into the serial format needed by the Bus Interface Unit.

After checking the Board ID and verifying that the module is receiving appropriate logic power from the Bus Interface Unit (which is reflected by the state of the module's Power LED), the Bus Interface Unit then reads the filtered, converted input data.

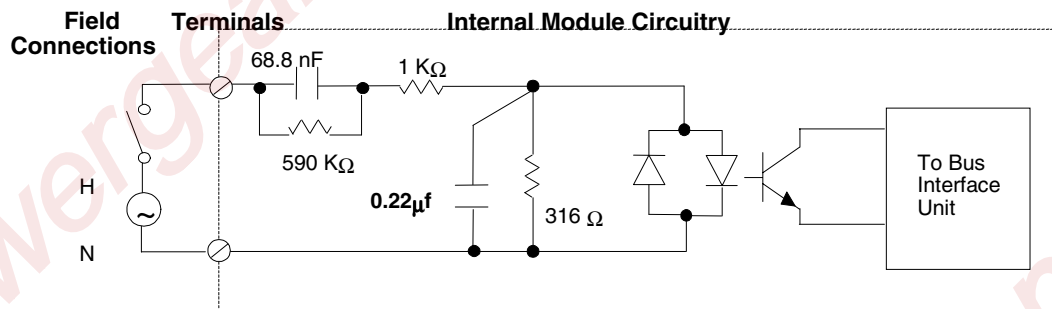

Module Specifications

Module Characteristics	
Rated Voltage	240 VAC
Input Voltage Range	0-265 VAC (47-63 Hz)
User Input Current	8.2 mA per point @ 240 VAC
Isolation: User input to logic, User input to frame ground, Group to group	250 VAC continuous, 1500 VAC for 1 minute. No isolation between individual points in a group.
Indicators	1 LED per point shows individual point status PWR LED indicates backplane and user power are present
Current Drawn from Bus Interface Unit Power Supply	77 mA maximum
Input Characteristics	
Input Impedance	typical (reactive) 38.5K @ 60Hz, 46.3K @ 50 Hz
On state voltage Off state voltage	155 VAC to 265 VAC 0 VAC to 40 VAC
On state Current Off state Current	4.0mA to 10mA 0mA to 1.5mA
On response time Off response time	20ms maximum 20ms maximum

Keying Locations

Optional keying locations for the 120VAC Grouped Input Module are shown below.

Keying Locations									
A	B	C	D	E	F	G	H	J	K
		x		x		x		x	

Field Wiring

I/O Terminal Block wiring assignments for this module are shown below. Inputs 1 to 8 are one isolated group and inputs 9 to 16 are another isolated group. If isolation is needed, each isolated group must have its own power supply. If isolation is not needed, one power supply can be used for all sixteen inputs.

The Terminal Block with box terminals has 25 terminals for each module, each of which accommodates one AWG #14 (avg 2.1mm² cross section) to AWG #22 (avg 0.36mm² cross section) wire, or two wires up to AWG #18 (avg. 0.86mm² cross section). When an external jumper is used, the wire capacity is reduced from AWG #14 (2.10mm²) to AWG #16 (1.32mm²).

The I/O Terminal Block with barrier terminals has 18 terminals per module. Each terminal can accommodate one or two wires up to AWG #14 (avg 2.1mm² cross section).

The I/O Terminal Block with Connectors has one 20-pin male connector per module. The mating connector is Amp part number 178289-8. Any tin-plated contact in the AMP D-3000 series can be used with the connector (Amp part number 1-175217-5 for high contact force receptacle for 20-24 gauge (0.20-0.56mm²) wires), 1-175218-5 for high contact force receptacle for 16-20 gauge (0.56-1.42mm²).

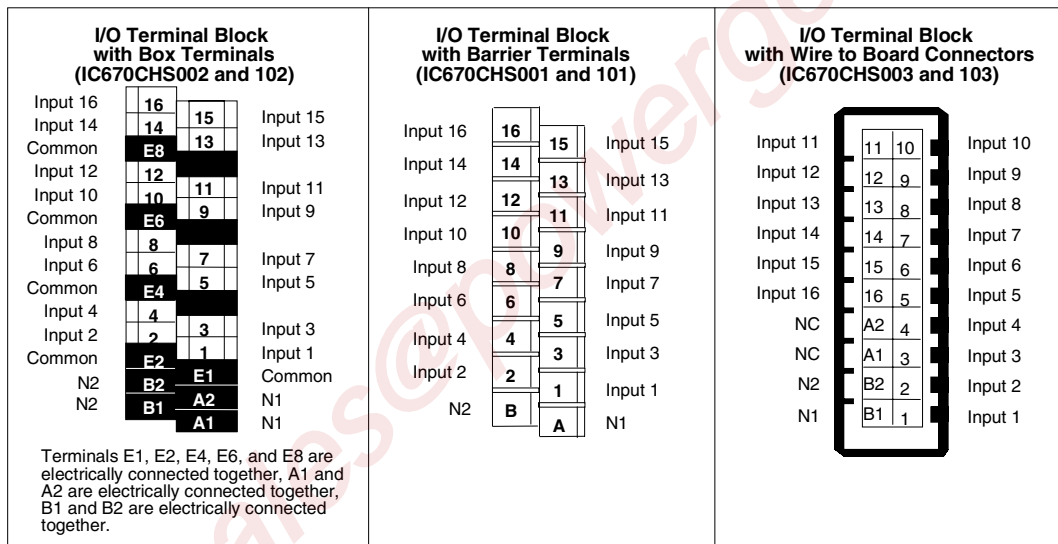

Wiring Examples with Auxiliary Terminal Blocks

An Auxiliary Terminal Block may be used to provide additional wiring terminals. Auxiliary Terminal Blocks have all terminals connected together internally. The Auxiliary Terminal Block with box terminals has 13 terminals, each of which accommodates one AWG #14 (avg 2.1mm² cross section) to AWG #22 (avg 0.36mm² cross section) wire, or two wires up to AWG #18 (avg. 0.86mm² cross section). The Auxiliary Terminal Block with barrier terminals has nine terminals, each of which can accommodate one or two wires up to AWG #14 (avg 2.1mm² cross section).

Example Connections for Wiring Two Isolated Groups

For an I/O Terminal Block with Box Terminals, an Auxiliary Terminal Block with Box Terminals can be used for power connections for one of the groups. Two external power supplies are used to provide isolation between inputs 1-8 and 9-16. Because all terminals on an Auxiliary Terminal Block are common, it can only be used for one group when isolation is needed. For the other group, an external terminal strip or the common terminals on the base might be used.

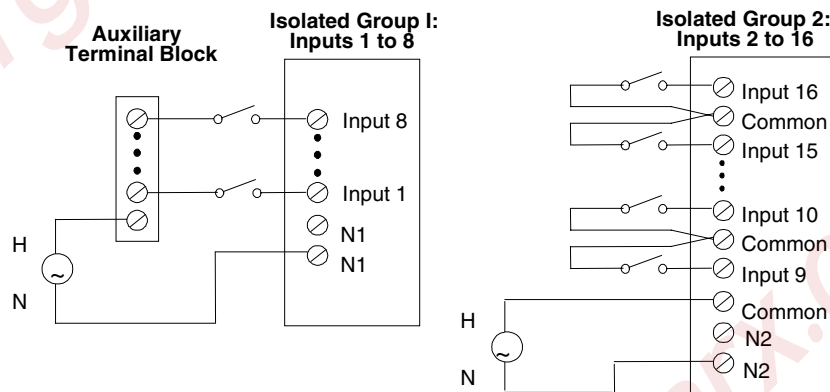

For an I/O Terminal Block with Barrier Terminals or an I/O Terminal Block with Wire to Board Connectors, an Auxiliary Terminal Block can be used for one isolated group as shown on the left above. An external terminal strip must be used for the other group.

Example Connections for Wiring Without Isolation

If two isolated groups are not needed, an Auxiliary Terminal Block might be used for the H connections for all 16 points. The following example shows a Terminal Block and Auxiliary Terminal Block with Barrier Terminals.

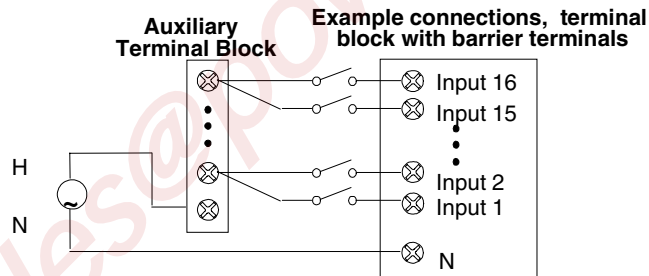

Chapter 6

24VDC Positive/Negative Discrete Input Module IC670MDL640

The 24 VDC Positive/Negative Input Module (IC670MDL640) provides a single group of 16 discrete inputs, which may be driven by positive or negative logic.

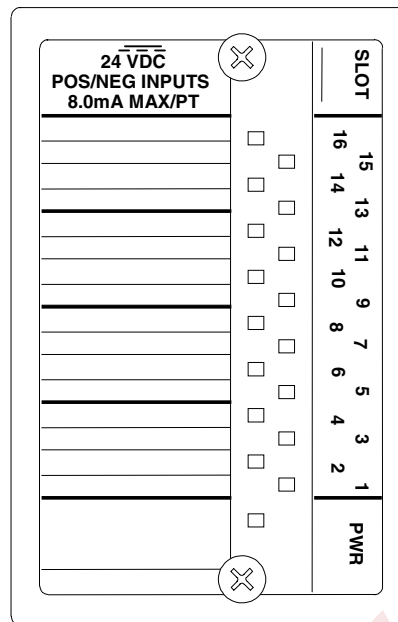

Power Sources

The module receives power from the Field Processor to run its own 5-volt logic. An external 24VDC supply is needed to power the input devices.

LEDs

Individual LEDs (logic side), visible through the transparent portion of the module top, indicate the on/off status of each input. The PWR LED is on when field and backplane power are present.

Host Interface

Intelligent processing for this module is performed by the Bus Interface Unit or elsewhere in the system. This includes configuring features such as input defaults and fault reporting. The module has 16 bits (two bytes) of discrete input data. A Bus Interface Unit is required to provide this input data to the host and/or local processor.

Module Operation

A network of resistors and capacitors establishes input thresholds and provides input filtering. Optoisolators provide isolation between the field inputs and the module's logic components. Data from all 16 inputs is placed into a data buffer. The module's circuit LEDs show the current states of the 16 inputs in this data buffer.

Parallel-to-serial converters change input data from the data buffer into the serial format needed by the Bus Interface Unit.

After checking the Board ID and verifying that the module is receiving appropriate logic power from the Bus Interface Unit (which is reflected by the state of the module's Power LED), the Bus Interface Module then reads the filtered, converted input data.

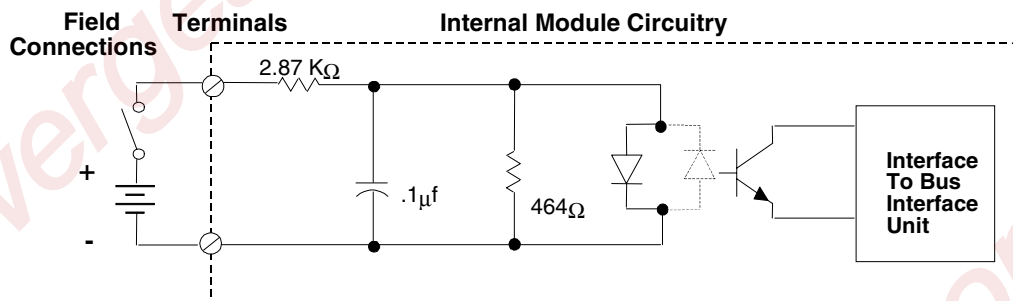

Orientation of the power supply depends upon whether inputs use positive or negative logic.

Positive or Negative Inputs

Inputs for this module can be either positive or negative inputs (all 16 inputs must be the same type). Both types of signal produce a logic 1 (true) when the switch is closed. Selection of positive or negative operation is made by the manner in which the external power supply is connected to the inputs and to the I/O Terminal Block.

Positive inputs receive current from input devices and supply current to the common or negative power bus. Input devices are connected between the positive power bus and the input terminals.

Negative inputs provide current to input devices and accept current from the common or positive power bus. Input devices are connected between the negative power bus and the input terminal.

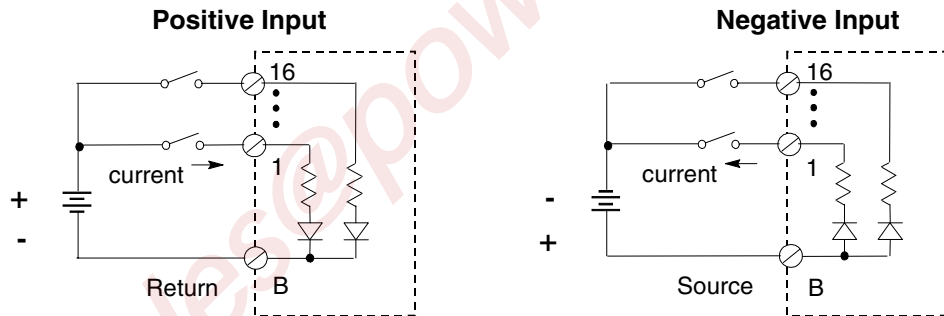

Module Specifications

Module Characteristics	
Rated Voltage	24VDC
Input Voltage Range	0-30 VDC
User Input Current	7.5 mA per point @ 24 VDC
Isolation: User input to logic, user input to frame ground, group to group	250 VAC continuous, 1500 VAC for 1 minute. No isolation between individual points in a group.
Indicators	1 LED per point shows individual point status PWR LED indicates field and backplane power are present
Current drawn from Bus Interface Unit Power Supply	75 mA, typical (all points on) 83 mA, maximum
Input Characteristics	
Input Impedance	3K typical
On state voltage	Positive logic: +15V to +30V Negative logic: -15V to -30V
Off state voltage	Positive logic: 0 to +5V Negative logic: 0 to -5V
On state Current	3.0mA to 8mA
Off state Current	0mA to 1.5mA
On response time	6ms typical, 10ms maximum
Off response time	6ms typical, 10ms maximum

Keying Locations

Optional keying locations for the 24VDC Positive/Negative Input Module are shown below.

Keying Locations									
A	B	C	D	E	F	G	H	J	K
x		x				x	x		

Field Wiring

The following illustration shows terminal assignments for the 24 VDC Positive/Negative Input Module.

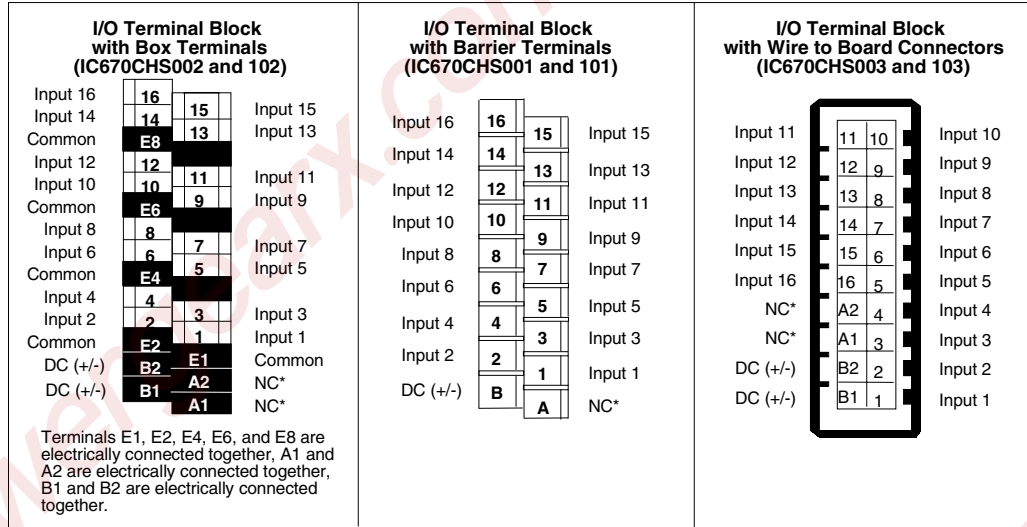

Connection to the A terminals (marked NC in the diagram above) is optional. They can be used as shown on the next page.

The Terminal Block with box terminals has 25 terminals for each module, each of which accommodates one AWG #14 (avg 2.1mm² cross section) to AWG #22 (avg 0.36mm² cross section) wire, or two wires up to AWG #18 (avg. 0.86mm² cross section). When an external jumper is used, the wire capacity is reduced from AWG #14 (2.10mm²) to AWG #16 (1.32mm²).

The I/O Terminal Block with barrier terminals has 18 terminals per module. Each terminal can accommodate one or two wires up to AWG #14 (avg 2.1mm² cross section).

The I/O Terminal Block with Connectors has one 20-pin male connector per module. The mating connector is Amp part number 178289-8. Any tin-plated contact in the AMP D-3000 series can be used with the connector (Amp part number 1-175217-5 for high contact force receptacle for 20-24 gauge (0.20-0.56mm²) wires), 1-175218-5 for high contact force receptacle for 16-20 gauge (0.56-1.42mm²).

Wiring Examples with Auxiliary Terminal Blocks

If the module is installed on an I/O Terminal Block with Barrier Terminals, an Auxiliary Terminal Block can be used to provide additional wiring terminals. For the I/O Terminal Block with Wire to Board Connectors, external connection points are usually preferred, although an Auxiliary Terminal Block can be used.

Auxiliary Terminal Blocks have all terminals connected together internally. The Auxiliary Terminal Block with box terminals has 13 terminals, each of which accommodates one AWG #14 (avg 2.1mm² cross section) to AWG #22 (avg 0.36mm² cross section) wire, or two wires up to AWG #18 (avg. 0.86mm² cross section). The Auxiliary Terminal Block with barrier terminals has nine terminals, each of which can accommodate one or two wires up to AWG #14 (avg 2.1mm² cross section).

The following illustration shows how an Auxiliary Terminal Block with Box Terminals can be used for power connections to an I/O Terminal Block with Box Terminals.

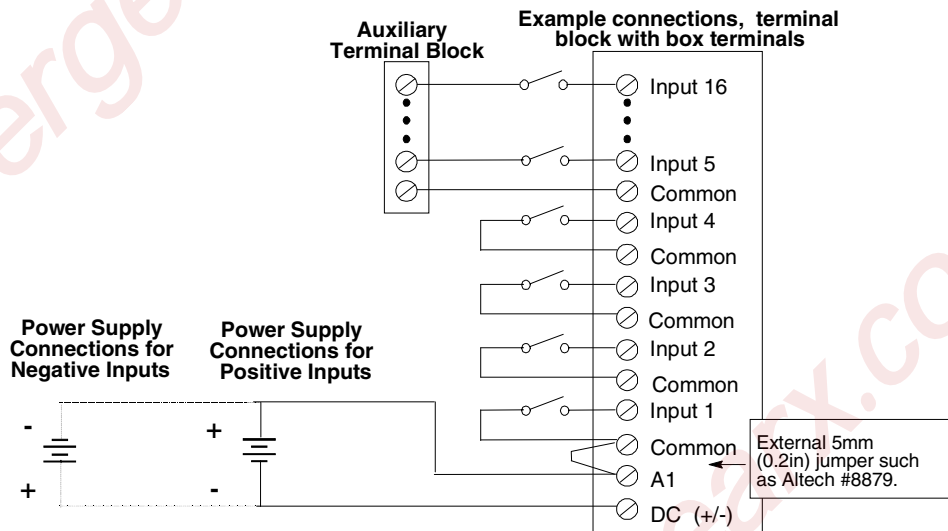

For an I/O Terminal Block with Barrier Terminals, an Auxiliary Terminal Block with Barrier Terminals might be connected as shown in the following example.

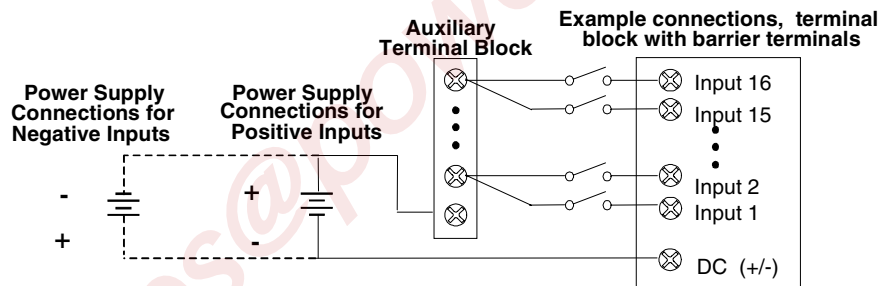

Chapter 7

48VDC Positive/Negative Discrete Input Module IC670MDL641

The 48 VDC Positive/Negative Input Module (IC670MDL641) provides a single group of 16 discrete inputs, which may be driven by positive or negative logic.

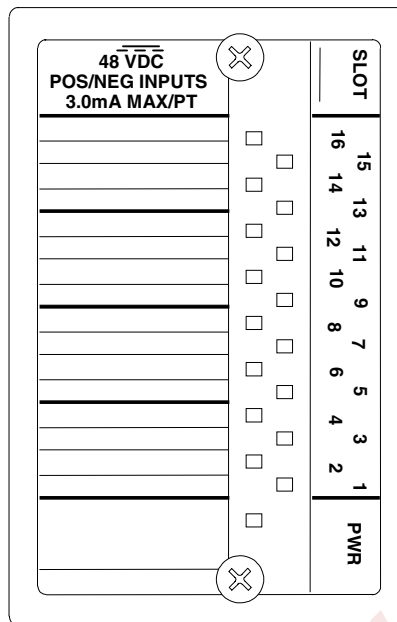

Power Sources

The module receives power from the Bus Interface Unity for its own operation. An external 48VDC supply is needed to power the input devices.

LEDs

Individual LEDs (logic side), visible through the transparent portion of the module top, indicate the on/off status of each input. The PWR LED is on when field and backplane power are present.

Host Interface

Intelligent processing for this module is performed by the Bus Interface Unit or elsewhere in the system. This includes configuring features such as input defaults and fault reporting. The module has 16 bits (two bytes) of discrete input data. A Bus Interface Unit is required to provide this input data to the host and/or local processor.

Module Operation

A network of resistors, capacitors, and zener diodes establishes input thresholds and provides input filtering. Optoisolators provide isolation between the field inputs and the module's logic components. An oscillator and switch form a sampling circuit that is transparent to the controller and the LEDs that indicate the state of the inputs. Data from all 16 inputs is placed into a data buffer. The module's circuit LEDs show the current states of the 16 inputs in this data buffer.

Parallel-to-serial converters change input data from the data buffer into the serial format needed by the Bus Interface Unit.

After checking the Board ID and verifying that the module is receiving appropriate logic power from the Bus Interface Unit (which is reflected by the state of the module's Power LED), the Bus Interface Module then reads the filtered, converted input data.

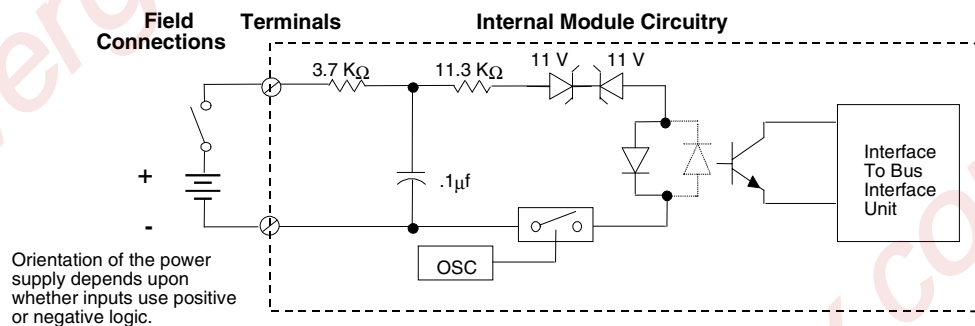

Positive or Negative Inputs

Inputs for this module can be either positive or negative inputs (all 16 inputs must be the same type). Both types of signal produce a logic 1 (true) when the switch is closed. Selection of positive or negative operation is made by the manner in which the external power supply is connected to the inputs and to the I/O Terminal Block.

Positive inputs receive current from input devices and supply current to the common or negative power bus. Input devices are connected between the positive power bus and the input terminals.

Negative inputs provide current to input devices and accept current from the common or positive power bus. Input devices are connected between the negative power bus and the input terminal.

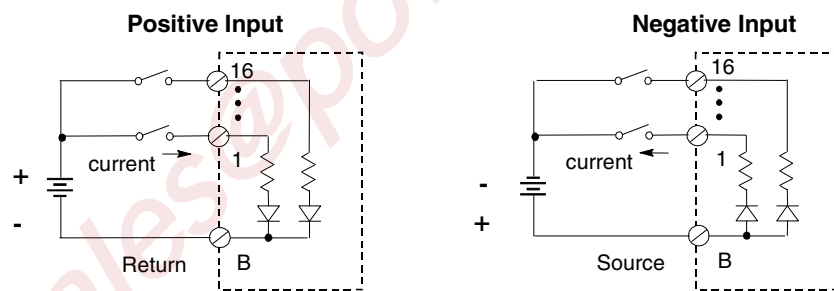

Module Specifications

Module Characteristics	
Rated Voltage	48VDC
Input Voltage Range	0-60 VDC
User Input Current	2.5 mA per point @ 48 VDC
Isolation: User input to logic, user input to frame ground, group to group	250 VAC continuous, 1500 VAC for 1 minute. No isolation between individual points in a group.
Indicators	1 LED per point shows individual point status PWR LED indicates field and backplane power are present
Current drawn from Bus Interface Unit Power Supply	83 mA, maximum
Input Characteristics	
Input Impedance	10K minimum
On state voltage	Positive logic: +34V to +60V Negative logic: -34V to -60V
Off state voltage	Positive logic: 0 to +10V Negative logic: 0 to -10V
On state Current	0.3mA to 3.0mA
Off state Current	0mA to 0.5mA
On response time	6ms typical, 10ms maximum
Off response time	6ms typical, 20ms maximum

Keying Locations

Optional keying locations for the 48VDC Positive/Negative Input Module are shown below.

Keying Locations									
A	B	C	D	E	F	G	H	J	K
	x		x			x	x		

Field Wiring

The following illustration shows terminal assignments for the 24 VDC Positive/Negative Input Module.

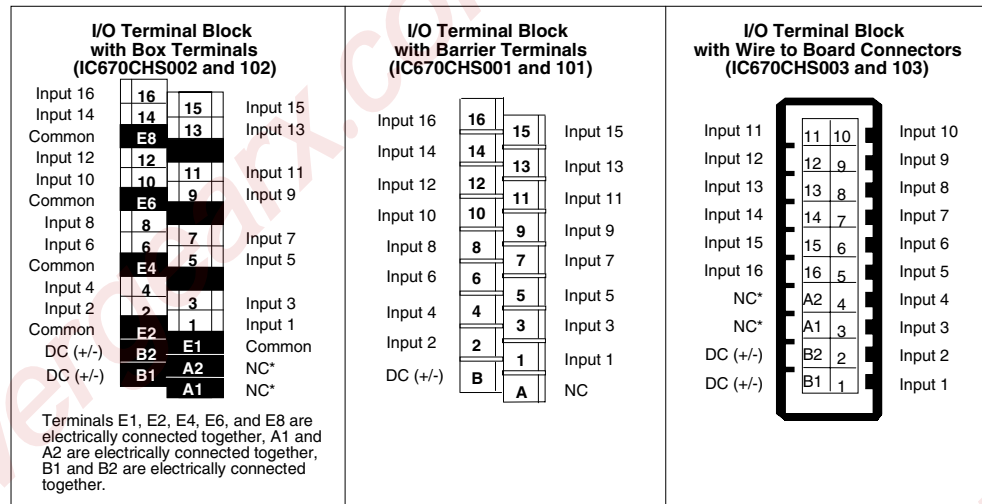

Connection to the A terminals (marked NC in the diagram above) is optional. They can be used as shown on the next page.

The Terminal Block with box terminals has 25 terminals for each module, each of which accommodates one AWG #14 (avg 2.1mm² cross section) to AWG #22 (avg 0.36mm² cross section) wire, or two wires up to AWG #18 (avg. 0.86mm² cross section). When an external jumper is used, the wire capacity is reduced from AWG #14 (2.10mm²) to AWG #16 (1.32mm²).

The I/O Terminal Block with barrier terminals has 18 terminals per module. Each terminal can accommodate one or two wires up to AWG #14 (avg 2.1mm² cross section).

The I/O Terminal Block with Connectors has one 20-pin male connector per module. The mating connector is Amp part number 178289-8. Any tin-plated contact in the AMP D-3000 series can be used with the connector (Amp part number 1-175217-5 for high contact force receptacle for 20-24 gauge (0.20-0.56mm²) wires), 1-175218-5 for high contact force receptacle for 16-20 gauge (0.56-1.42mm²).

Wiring Examples with Auxiliary Terminal Blocks

If the module is installed on an I/O Terminal Block with Barrier Terminals, an Auxiliary Terminal Block can be used to provide additional wiring terminals. For the I/O Terminal Block with Wire to Board Connectors, external connection points are usually preferred, although an Auxiliary Terminal Block can be used.

Auxiliary Terminal Blocks have all terminals connected together internally. The Auxiliary Terminal Block with box terminals has 13 terminals, each of which accommodates one AWG #14 (avg 2.1mm² cross section) to AWG #22 (avg 0.36mm² cross section) wire, or two wires up to AWG #18 (avg. 0.86mm² cross section). The Auxiliary Terminal Block with barrier terminals has nine terminals, each of which can accommodate one or two wires up to AWG #14 (avg 2.1mm² cross section).

The following illustration shows how an Auxiliary Terminal Block with Box Terminals can be used for power connections to an I/O Terminal Block with Box Terminals.

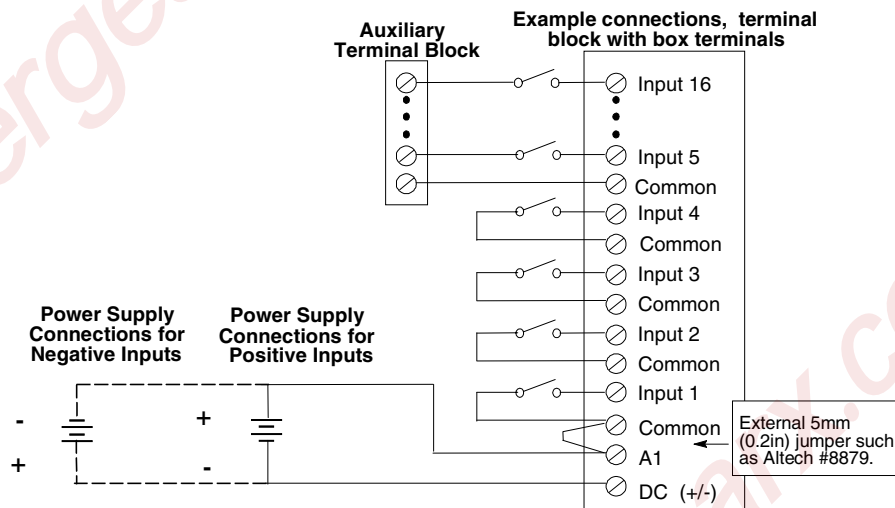

For an I/O Terminal Block with Barrier Terminals, an Auxiliary Terminal Block with Barrier Terminals might be connected as shown in the following example.

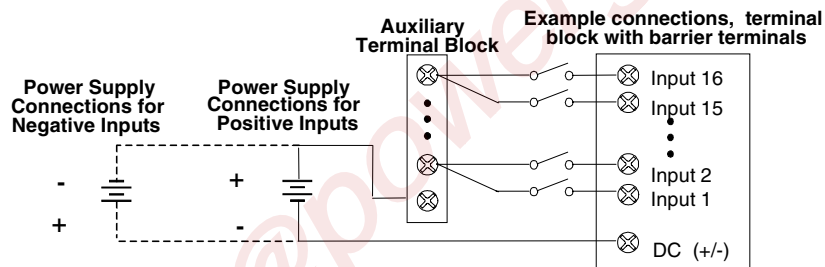

Chapter 8

125VDC Positive/Negative Discrete Input Module IC670MDL642

The 125VDC Positive/Negative Input Module (IC670MDL642) provides a single group of 16 discrete inputs, which may be driven by positive or negative logic.

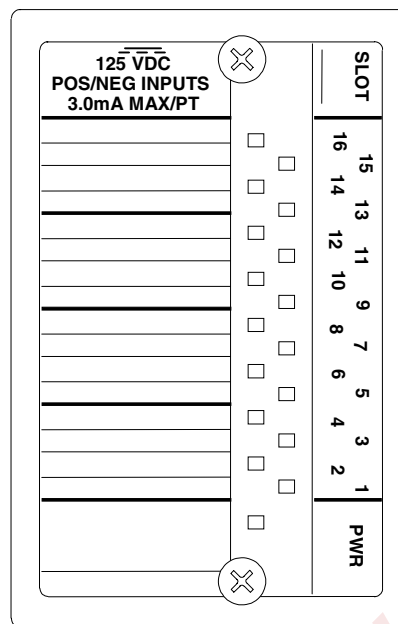

Power Sources

The module receives power from the Bus Interface Unity for its own operation. An external 125VDC supply is needed to power the input devices.

LEDs

Individual LEDs (logic side), visible through the transparent portion of the module top, indicate the on/off status of each input. The PWR LED is on when backplane power is present.

Host Interface

Intelligent processing for this module is performed by the Bus Interface Unit or elsewhere in the system. This includes configuring features such as input defaults and fault reporting. The module has 16 bits (two bytes) of discrete input data. A Bus Interface Unit is required to provide this input data to the host and/or local processor.

Module Operation

A network of resistors, capacitors, and zener diodes establishes input thresholds and provides input filtering. Optoisolators provide isolation between the field inputs and the module's logic components. An oscillator and switch form a sampling circuit that is transparent to the controller and the LEDs that indicate the state of the inputs. Data from all 16 inputs is placed into a data buffer. The module's circuit LEDs show the current states of the 16 inputs in this data buffer.

Parallel-to-serial converters change input data from the data buffer into the serial format needed by the Bus Interface Unit.

After checking the Board ID and verifying that the module is receiving appropriate logic power from the Bus Interface Unit (which is reflected by the state of the module's Power LED), the Bus Interface Module then reads the filtered, converted input data.

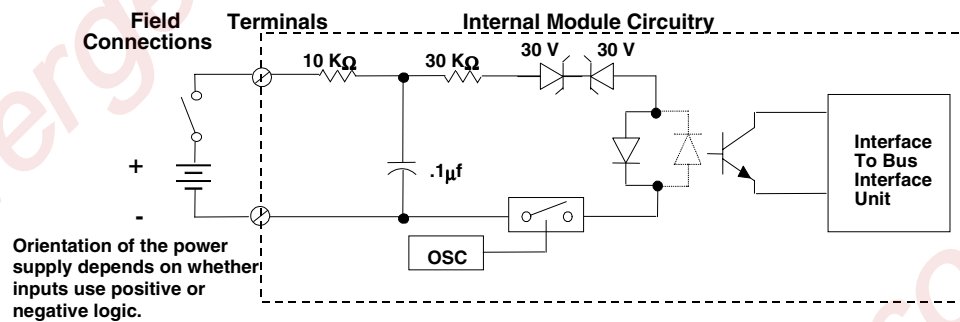

Positive or Negative Inputs

Inputs for this module can be either positive or negative inputs (all 16 inputs must be the same type). Both types of signal produce a logic 1 (true) when the switch is closed. Selection of positive or negative operation is made by the manner in which the external power supply is connected to the inputs and to the I/O Terminal Block.

Positive inputs receive current from input devices and supply current to the common or negative power bus. Input devices are connected between the positive power bus and the input terminals.

Negative inputs provide current to input devices and accept current from the common or positive power bus. Input devices are connected between the negative power bus and the input terminal.

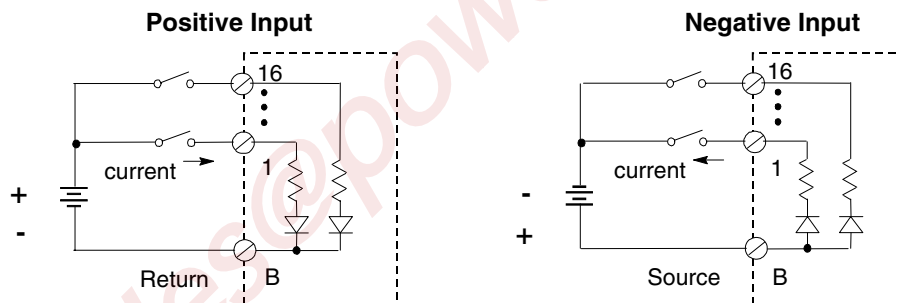

Module Specifications

Module Characteristics	
Rated Voltage	125VDC rated
Input Voltage Range	0-150 VDC
User Input Current	2.5 mA per point @ 125 VDC
Isolation: User input to logic, user input to frame ground, group to group	250 VAC continuous, 1500 VAC for 1 minute. No isolation between individual points in a group.
Indicators	1 LED per point shows individual point status PWR LED indicates field and backplane power are present
Current drawn from Bus Interface Unit Power Supply	77 mA, maximum
Input Characteristics	
Input Impedance	40K minimum
On state voltage	Positive logic: +79V to +150V Negative logic: -79V to -150V
Off state voltage	Positive logic: 0 to +30V Negative logic: 0 to -30V
On state Current	0.3mA to 3.0mA
Off state Current	0mA to 0.5mA
On response time	6ms typical, 10ms maximum
Off response time	6ms typical, 20ms maximum

Keying Locations

Optional keying locations for the 48VDC Positive/Negative Input Module are shown below.

Keying Locations									
A	B	C	D	E	F	G	H	J	K
x				x		x	x		

Field Wiring

The following illustration shows terminal assignments for the 125VDC Positive/Negative Input Module.

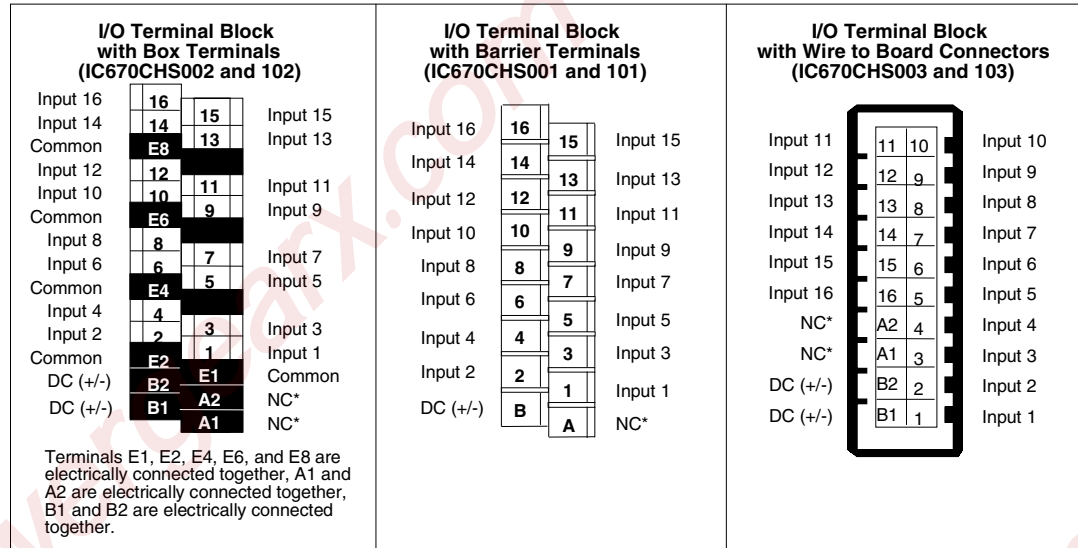

Connection to the A terminals (marked NC in the diagram above) is optional. They can be used as shown on the next page.

The Terminal Block with box terminals has 25 terminals for each module, each of which accommodates one AWG #14 (avg 2.1mm² cross section) to AWG #22 (avg 0.36mm² cross section) wire, or two wires up to AWG #18 (avg. 0.86mm² cross section). When an external jumper is used, the wire capacity is reduced from AWG #14 (2.10mm²) to AWG #16 (1.32mm²).

The I/O Terminal Block with barrier terminals has 18 terminals per module. Each terminal can accommodate one or two wires up to AWG #14 (avg 2.1mm² cross section).

The I/O Terminal Block with Connectors has one 20-pin male connector per module. The mating connector is Amp part number 178289-8. Any tin-plated contact in the AMP D-3000 series can be used with the connector (Amp part number 1-175217-5 for high contact force receptacle for 20-24 gauge (0.20-0.56mm²) wires), 1-175218-5 for high contact force receptacle for 16-20 gauge (0.56-1.42mm²).

Wiring Examples with Auxiliary Terminal Blocks

If the module is installed on an I/O Terminal Block with Barrier Terminals, an Auxiliary Terminal Block can be used to provide additional wiring terminals. For the I/O Terminal Block with Wire to Board Connectors, external connection points are usually preferred, although an Auxiliary Terminal Block can be used.

Auxiliary Terminal Blocks have all terminals connected together internally. The Auxiliary Terminal Block with box terminals has 13 terminals, each of which accommodates one AWG #14 (avg 2.1mm² cross section) to AWG #22 (avg 0.36mm² cross section) wire, or two wires up to AWG #18 (avg. 0.86mm² cross section). The Auxiliary Terminal Block with barrier terminals has nine terminals, each of which can accommodate one or two wires up to AWG #14 (avg 2.1mm² cross section).

The following illustration shows how an Auxiliary Terminal Block with Box Terminals can be used for power connections to an I/O Terminal Block with Box Terminals.

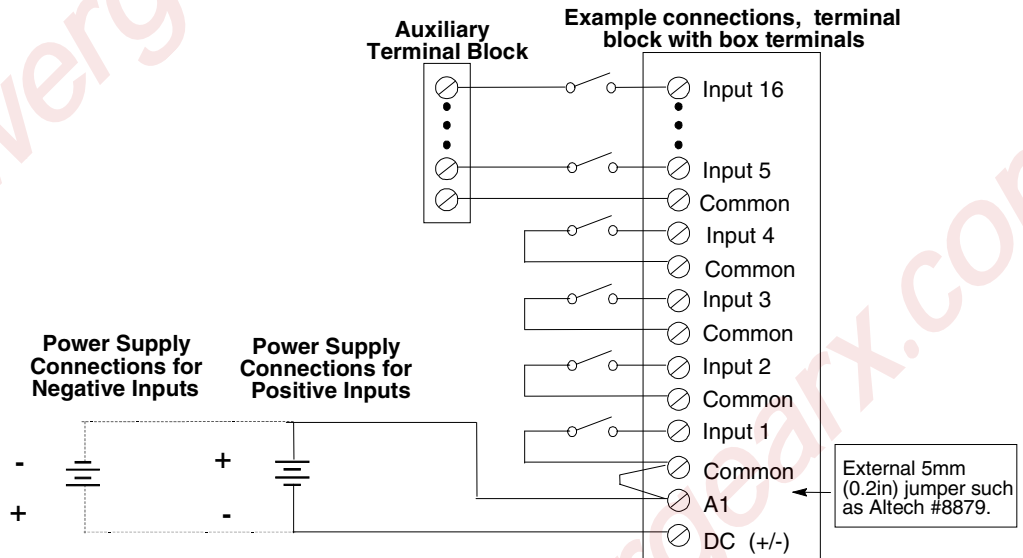

For an I/O Terminal Block with Barrier Terminals, an Auxiliary Terminal Block with Barrier Terminals might be connected as shown in the following example.

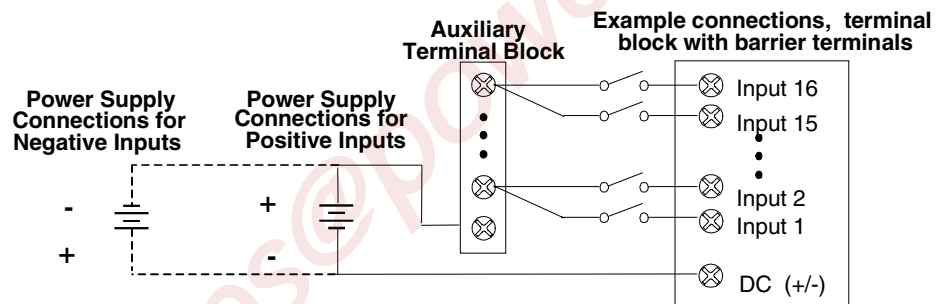

Chapter 9

5/12VDC Positive/Negative Discrete Input Module IC670MDL643

The 5/12VDC Positive/Negative Input Module (IC670MDL643) provides a single group of 16 discrete inputs arranged in two groups of 8. Each point may be driven by positive or negative logic.

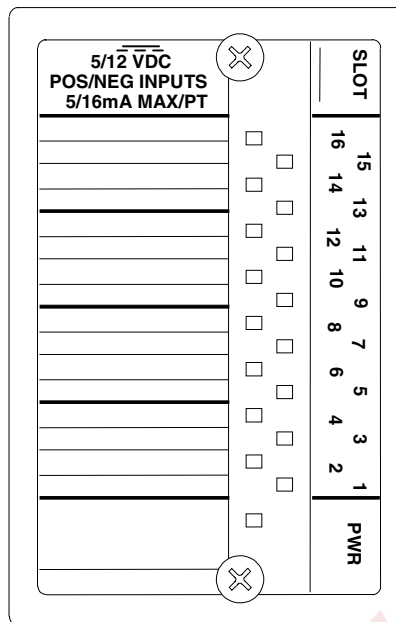

Power Sources

The module receives power from the Bus Interface Unity for its own operation. An external 5VDC or 12VDC supply is needed to power the input devices.

LEDs

Individual LEDs (logic side), visible through the transparent portion of the module top, indicate the on/off status of each input. The PWR LED is on when field and backplane power are present.

Host Interface

Intelligent processing for this module is performed by the Bus Interface Unit or elsewhere in the system. This includes configuring features such as input defaults and fault reporting. The module has 16 bits (two bytes) of discrete input data. A Bus Interface Unit is required to provide this input data to the host and/or local processor.

Module Operation

A network of resistors, capacitors, and diodes establishes input thresholds and provides input filtering. Optoisolators provide isolation between the field inputs and the module's logic components. Data from all 16 inputs is placed into a data buffer. The module's circuit LEDs show the current states of the 16 inputs in this data buffer.

Parallel-to-serial converters change input data from the data buffer into the serial format needed by the Bus Interface Unit.

After checking the Board ID and verifying that the module is receiving appropriate logic power from the Bus Interface Unit (which is reflected by the state of the module's Power LED), the Bus Interface Module then reads the filtered, converted input data.

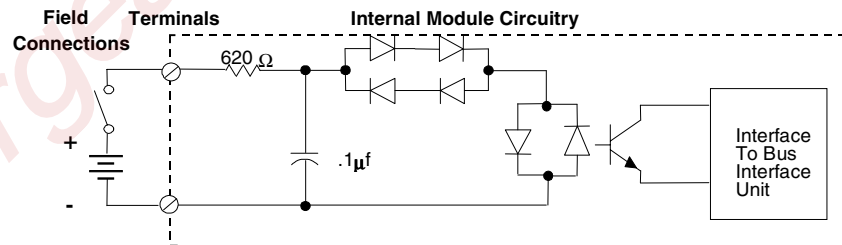

Orientation of the power supply depends upon whether inputs use positive or negative logic.

Positive or Negative Inputs

Each group of 8 inputs can be either positive or negative inputs. For example, group 1 (inputs 1-8) may be positive logic and group 2 (inputs 9-16) may be negative logic. Both types of signal produce a logic 1 (true) when the switch is closed. Each group may also support different logic levels. For example, group 1 may be +5 VDC and group 2 may be -12 VDC.

Selection of positive or negative operation is made by the manner in which the external power supply is connected to the inputs and to the I/O Terminal Block, as shown below

Positive inputs receive current from input devices and supply current to the common or negative power bus. Input devices are connected between the positive power bus and the input terminals.

Negative inputs provide current to input devices and accept current from the common or positive power bus. Input devices are connected between the negative power bus and the input terminal.

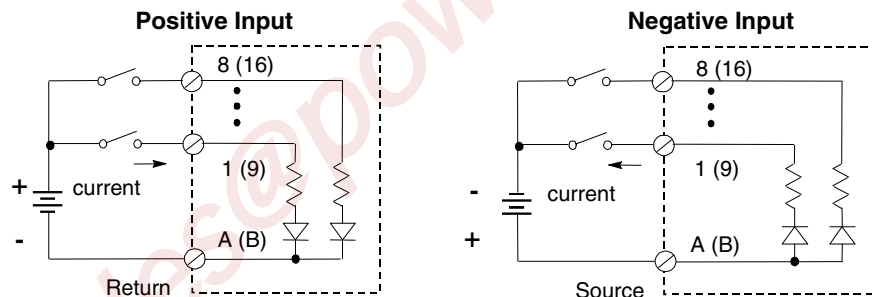

Module Specifications

Module Characteristics	
Rated Voltage	5/12VDC
Input Voltage Range	0-15 VDC
User Input Current	5 mA @ 5 VDC and 15 mA @ 15 VDC typical
Isolation: User input to logic, user input to frame ground, Group to group Point to point	250 VAC continuous, 1500 VAC for 1 minute. 150 VAC continuous No isolation between individual points in a group
Indicators	1 LED per point shows individual point status PWR LED indicates field and backplane power are present
Current drawn from Bus Interface Unit Power Supply	80 mA, maximum
Input Characteristics	
Input Impedance	1K Ohms typical
On state voltage	Positive logic: +3.6V to +15V Negative logic: -3.6V to -15V
Off state voltage	Positive logic: 0 to +1.6V Negative logic: 0 to -1.6V
On state Current	2.5mA to 16mA
Off state Current	0mA to 0.3mA
On response time	300 μ s typical, 550 μ s maximum
Off response time	1 ms typical, 1.2 ms maximum

Number of Inputs On

Ambient temperatures above 50 deg. C limit the number of inputs that can be ON at the same time:

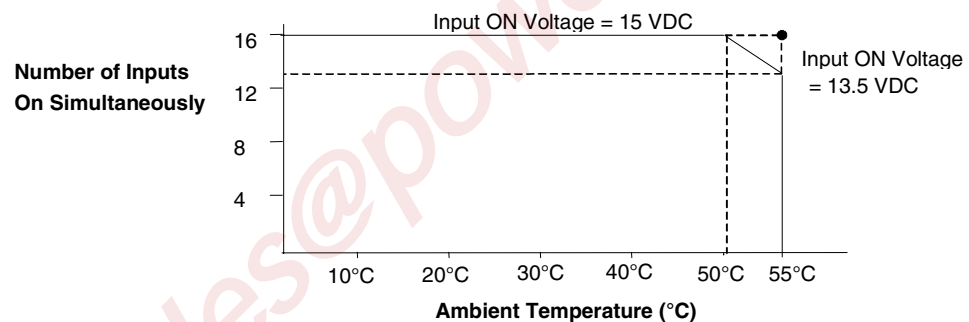

Keying Locations

Optional keying locations for the 5/12VDC Positive/Negative Input Module are shown below.

Keying Locations									
A	B	C	D	E	F	G	H	J	K
x	x					x	x		

Field Wiring

The following illustration shows terminal assignments for the 5/22VDC Positive/Negative Input Module.

**I/O Terminal Block
with Box Terminals
(IC670CHS002 and 102)**

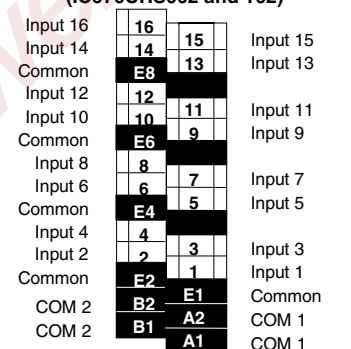

Terminals E1, E2, E4, E6, and E8 are electrically connected together, A1 and A2 are electrically connected together, B1 and B2 are electrically connected together.

**I/O Terminal Block
with Barrier Terminals
(IC670CHS001 and 101)**

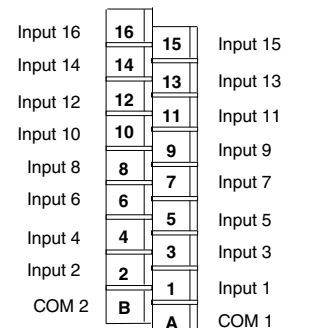

**I/O Terminal Block
with Wire to Board Connectors
(IC670CHS003 and 103)**

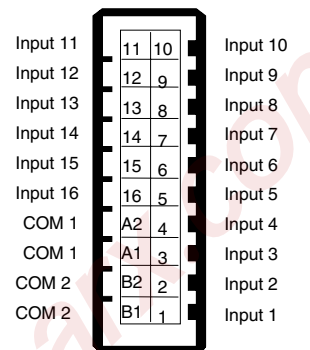

The Terminal Block with box terminals has 25 terminals for each module, each of which accommodates one AWG #14 (avg 2.1mm² cross section) to AWG #22 (avg 0.36mm² cross section) wire, or two wires up to AWG #18 (avg. 0.86mm² cross section). When an external jumper is used, the wire capacity is reduced from AWG #14 (2.10mm²) to AWG #16 (1.32mm²).

The I/O Terminal Block with barrier terminals has 18 terminals per module. Each terminal can accommodate one or two wires up to AWG #14 (avg 2.1mm² cross section).

The I/O Terminal Block with Connectors has one 20-pin male connector per module. The mating connector is Amp part number 178289-8. Any tin-plated contact in the AMP D-3000 series can be used with the connector (Amp part number 1-175217-5 for high contact force receptacle for 20-24 gauge (0.20-0.56mm²) wires), 1-175218-5 for high contact force receptacle for 16-20 gauge (0.56-1.42mm²).

Wiring Examples with Auxiliary Terminal Blocks

An Auxiliary Terminal Block may be required to provide additional wiring terminals. Auxiliary Terminal Blocks have all terminals connected together internally. The Auxiliary Terminal Block with box terminals has 13 terminals, each of which accommodates one AWG #14 (avg 2.1mm² cross section) to AWG #22 (avg 0.36mm² cross section) wire, or two wires up to AWG #18 (avg. 0.86mm² cross section). The Auxiliary Terminal Block with barrier terminals has nine terminals, each of which can accommodate one or two wires up to AWG #14 (avg 2.1mm² cross section).

Example Connections for Wiring Two Isolated Groups

For an I/O Terminal Block with Box Terminals, an Auxiliary Terminal Block with Box Terminals can be used for power connections for one of the groups. Two external power supplies are used to provide isolation between inputs 1-8 and 9-16. Because all terminals on an Auxiliary Terminal Block are common, it can only be used for one group when isolation is needed. For the other group, an external terminal strip or the common terminals on the base might be used.

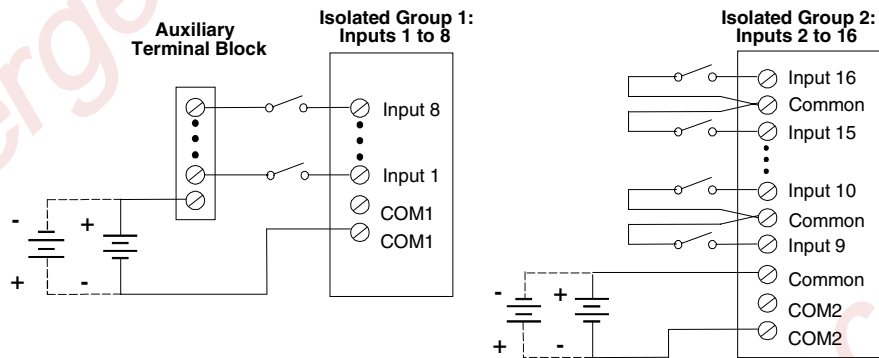

For an I/O Terminal Block with Barrier Terminals or an I/O Terminal Block with Wire to Board Connectors, an Auxiliary Terminal Block can be used for one isolated group as shown on the left above. An external terminal strip must be used for the other group.

Example Connections for Wiring Without Isolation

If two isolated groups are not needed, an Auxiliary Terminal Block might be used for the power connections for all 16 points. The following example shows a Terminal Block and Auxiliary Terminal Block with Barrier Terminals.

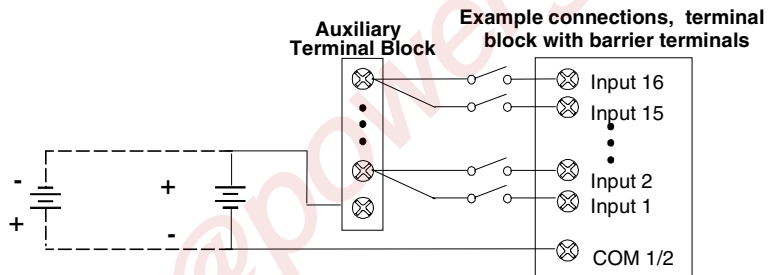

Chapter 10

24VDC Positive/Negative Fast Discrete Input Module IC670MDL644

The 24VDC Positive/Negative Input Module (IC670MDL644) provides a single group of 16 discrete inputs which may be driven by positive or negative logic.

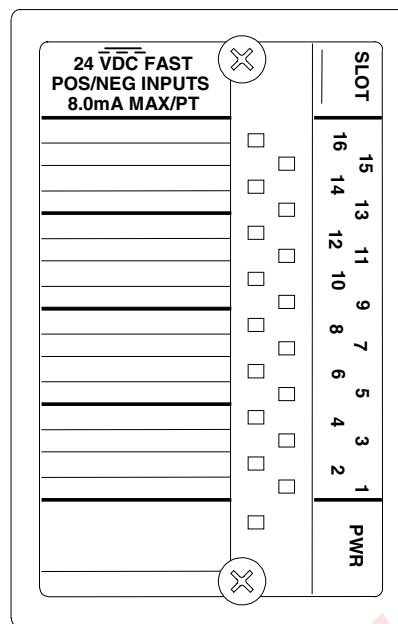

Power Sources

The module receives power from the Bus Interface Unity for its own operation. An external 24VDC supply is needed to power the input devices.

LEDs

Individual LEDs (logic side), visible through the transparent portion of the module top, indicate the on/off status of each input. The PWR LED is on when field and backplane power are present.

Host Interface

Intelligent processing for this module is performed by the Bus Interface Unit or elsewhere in the system. This includes configuring features such as input defaults and fault reporting. The module has 16 bits (two bytes) of discrete input data. A Bus Interface Unit is required to provide this input data to the host and/or local processor.

Module Operation

A network of resistors and capacitors establishes input thresholds and provides input filtering. Optoisolators provide isolation between the field inputs and the module's logic components. Data from all 16 inputs is placed into a data buffer. The module's circuit LEDs show the current states of the 16 inputs in this data buffer.

Parallel-to-serial converters change input data from the data buffer into the serial format needed by the Bus Interface Unit.

After checking the Board ID and verifying that the module is receiving appropriate logic power from the Bus Interface Unit (which is reflected by the state of the module's Power LED), the Bus Interface Module then reads the filtered, converted input data.

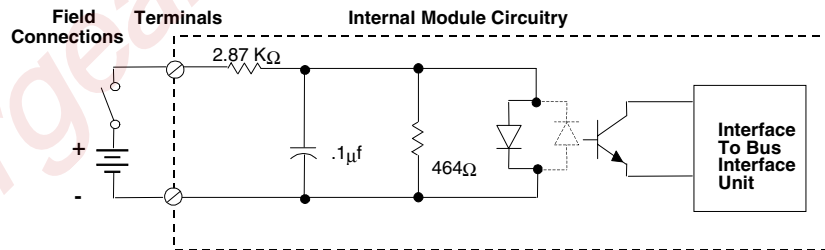

Orientation of the power supply depends upon whether inputs use positive or negative logic.

Positive or Negative Inputs

Inputs for this module can be either positive or negative inputs (all 16 inputs must be the same type). Both types of signal produce a logic 1 (true) when the switch is closed. Selection of positive or negative operation is made by the manner in which the external power supply is connected to the inputs and to the I/O Terminal Block.

Positive inputs receive current from input devices and supply current to the common or negative power bus. Input devices are connected between the positive power bus and the input terminals.

Negative inputs provide current to input devices and accept current from the common or positive power bus. Input devices are connected between the negative power bus and the input terminal.

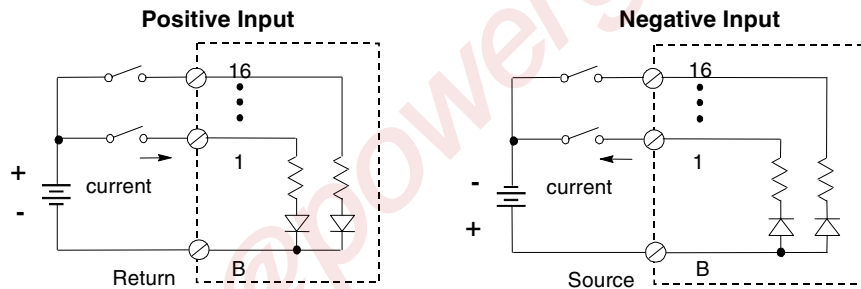

Module Specifications

Module Characteristics	
Rated Voltage	24VDC
Input Voltage Range	0-30 VDC
User Input Current	8.0 mA per point @ 24 VDC
Isolation: User input to logic, user input to frame ground, Point to point	250 VAC continuous, 1500 VAC for 1 minute. No isolation between individual points in a group
Indicators	1 LED per point shows individual point status PWR LED indicates field and backplane power are present
Current drawn from Bus Interface Unit Power Supply	80 mA
Input Characteristics	
Input Impedance	3K Ohms typical
On state voltage	Positive logic: +15V to +30V Negative logic: -15V to -30V
Off state voltage	Positive logic: 0 to +5V Negative logic: 0 to -5V
On state Current Off state Current	3.0mA to 8.0mA 0mA to 1.5mA
On response time Off response time	25 μ s typical, 60 μ s maximum 100 μ s typical, 150 μ s maximum

Keying Locations

Optional keying locations for the 24VDC Positive/Negative Fast Input Module are shown below.

Keying Locations									
A	B	C	D	E	F	G	H	J	K
x		x				x	x		

Field Wiring

The following illustration shows terminal assignments for the 24VDC Positive/Negative Fast Input Module.

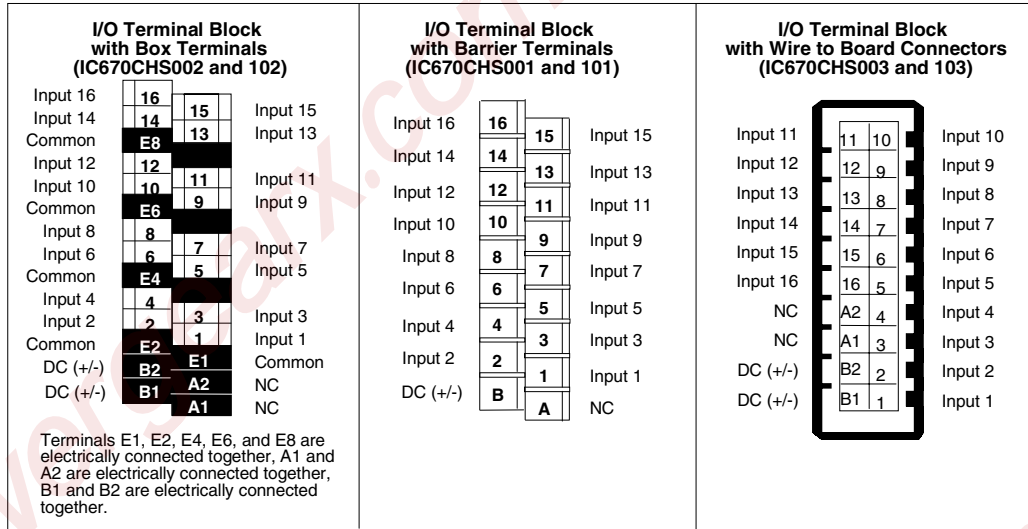

Connection to the A terminals (marked NC in the diagram above) is optional. They can be used as shown on the next page.

The Terminal Block with box terminals has 25 terminals for each module, each of which accommodates one AWG #14 (avg 2.1mm² cross section) to AWG #22 (avg 0.36mm² cross section) wire, or two wires up to AWG #18 (avg. 0.86mm² cross section). When an external jumper is used, the wire capacity is reduced from AWG #14 (2.10mm²) to AWG #16 (1.32mm²).

The I/O Terminal Block with barrier terminals has 18 terminals per module. Each terminal can accommodate one or two wires up to AWG #14 (avg 2.1mm² cross section).

The I/O Terminal Block with Connectors has one 20-pin male connector per module. The mating connector is Amp part number 178289-8. Any tin-plated contact in the AMP D-3000 series can be used with the connector (Amp part number 1-175217-5 for high contact force receptacle for 20-24 gauge (0.20-0.56mm²) wires), 1-175218-5 for high contact force receptacle for 16-20 gauge (0.56-1.42mm²).

Wiring Examples with Auxiliary Terminal Blocks

If the module is installed on an I/O Terminal Block with Barrier Terminals, an Auxiliary Terminal Block can be used to provide additional wiring terminals. For the I/O Terminal Block with Wire to Board Connectors, external connection points are usually preferred, although an Auxiliary Terminal Block can be used.

Auxiliary Terminal Blocks have all terminals connected together internally. The Auxiliary Terminal Block with box terminals has 13 terminals, each of which accommodates one AWG #14 (avg 2.1mm² cross section) to AWG #22 (avg 0.36mm² cross section) wire, or two wires up to AWG #18 (avg. 0.86mm² cross section). The Auxiliary Terminal Block with barrier terminals has nine terminals, each of which can accommodate one or two wires up to AWG #14 (avg 2.1mm² cross section).

The following illustration shows how an Auxiliary Terminal Block with Box Terminals can be used for power connections to an I/O Terminal Block with Box Terminals.

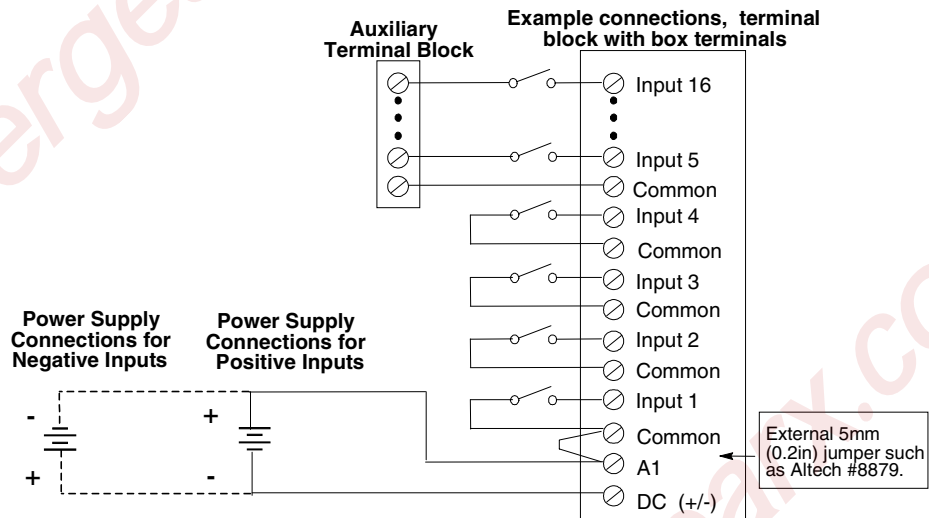

For an I/O Terminal Block with Barrier Terminals, an Auxiliary Terminal Block with Barrier Terminals might be connected as shown in the following example.

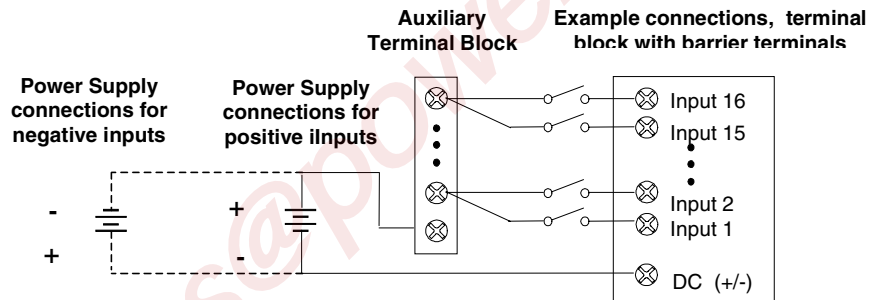

Chapter 11

12-120VAC 1.0A Discrete Output Module IC670MDL330

The 12-120VAC 1.0 Amp Output Module (IC670MDL330) provides a single group of 16 discrete outputs.

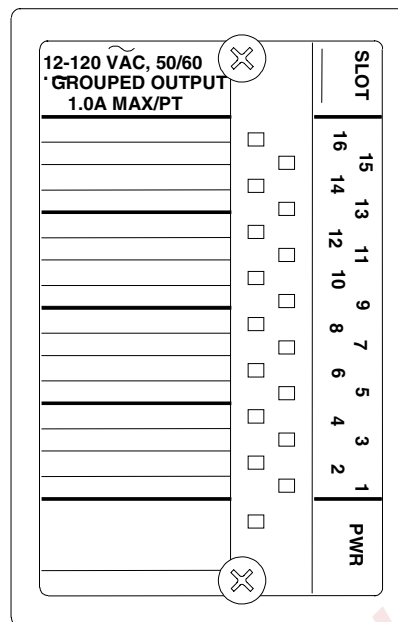

Power Sources

The power that runs the module itself comes from the power supply in the Bus Interface Unit. An external source of AC power must be provided to power the loads.

LEDs

Individual LEDs (logic side), visible through the transparent portion of the module top, indicate the on/off status of each output.

Host Interface

Intelligent processing for this module is performed by the Bus Interface Unit or elsewhere in the system. This includes configuring features such as output default and fault reporting. The module has 16 bits (two bytes) of discrete output data. A Bus Interface Unit is required to obtain this output data from the host and/or local processor.

Module Operation

After checking the Board ID and verifying that the module is receiving appropriate logic power from the Bus Interface Unit (as reflected by the state of the module's Power LED), the Bus Interface Unit then sends output data to the module in serial format. During transmission, the module automatically loops this data back to the Bus Interface Unit for verification. The module also provides the Bus Interface Unit with the diagnostic status of the fuse on the output group. Serial-to-parallel converters convert this data into the parallel format needed by the module. Optoisolators isolate the module's logic components from field outputs. Power from the external power supply is used to power the switches that drive the loads.

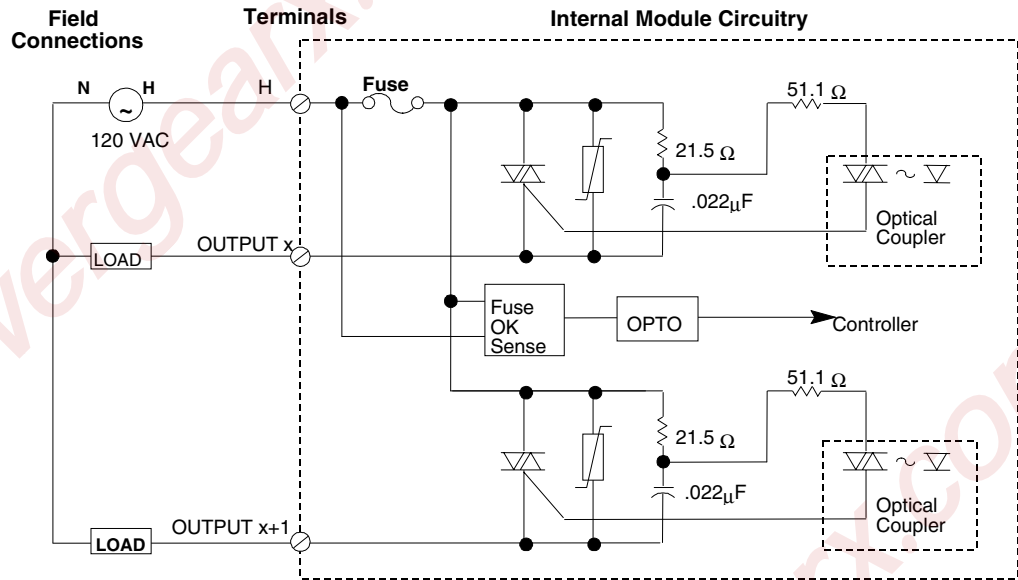

Module Specifications

Module Characteristics	
Rated Voltage	12 to 120 VAC
Output Voltage Range	10 to 132 VAC, 47 - 63 Hz
Output Current	1 amp maximum per point 4 amps maximum per module (see Maximum Load Rating)
Outputs per module	1 group of 16
Indicators	Logic side LEDs indicate on/off status of each output Fuse OK LED for all 16 groups
Isolation:	
User input to logic, user input to frame ground	250 VAC continuous, 1500 VAC for 1 minute
Point to point	No isolation between individual points in a group.
Current Drawn from Bus Interface Unit Power Supply	275 mA with all points on. See the BIU power requirements chart on the next page.
Output Characteristics	
Inrush Current	10A maximum for one cycle (20mS)
Maximum Load Current (resistive)	1.0 A from 10 VAC to 132 VAC
Minimum Load Current	10 mA per point from 10 VAC to 132 VAC
Output Voltage Drop	2.0 volts maximum
Output Leakage Current	less than 2 mA maximum at 120 VAC
Response Time-On	less than 1/2 cycle
Response Time-Off	less than 1/2 cycle
Protection (each output)	Snubber: (R=21.5 ohms, C=0.022 μ fd)

Keying Locations

Optional keying locations for the 12-120VAC 1.0A Output Module are shown below.

Keying Locations									
A	B	C	D	E	F	G	H	J	K
	x			x	x		x		

Maximum Load Rating

The maximum rating of 1 Amp per point applies to the long term capacity of each point. Because of overall heat dissipation and current capacity of module pins, the maximum current capacity for each module is limited to 4 Amps with proper derating.

The following illustration shows an example of the relationship between total module load current and ambient temperature.

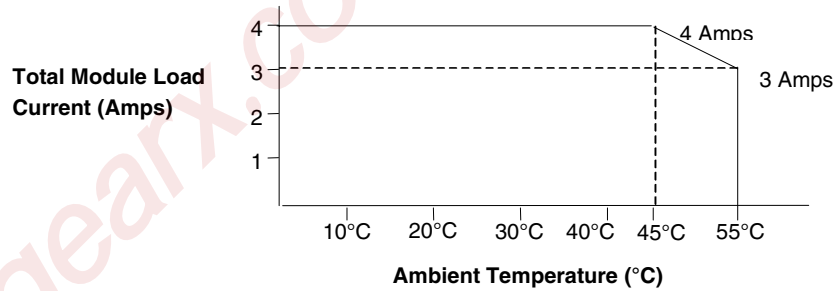

Each output on this module is capable of transiently conducting a surge current that is much greater than its long-term current rating.

The rate at which such surges can be repeated depends on the current rating of the device and the duty cycle (percent of time the device is ON). For typical incandescent devices operating at a 50% duty cycle, the following repetition rates apply:

Steady-state Current (Amps)	Repetition Rate (Hz)
0.5	5
1	1

BIU Power Required, per Point

The module's BIU power requirement increases as the number of points that are simultaneously on increases. The chart below shows the relationship between the power required and the number of points that are on.

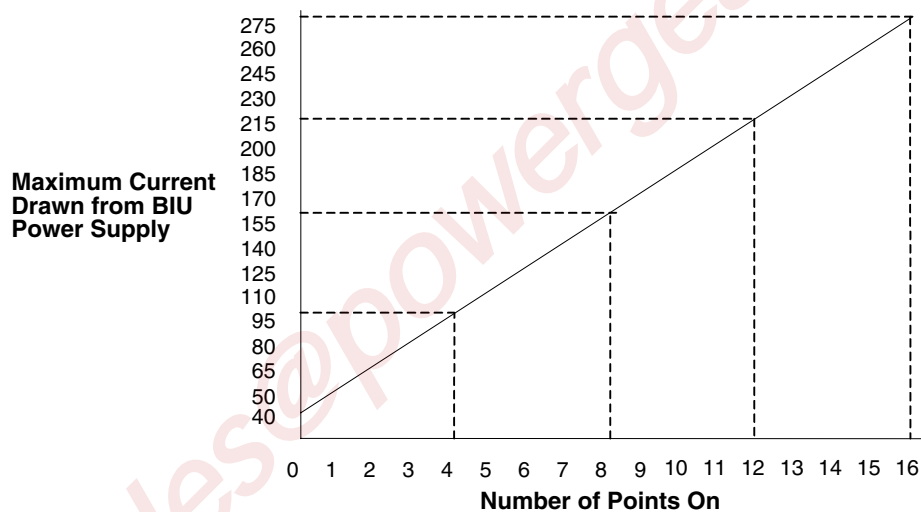

Fusing

The module's 5 Amp fuse protects the entire module from exceeding the maximum current rating. The fuse does not protect output points from exceeding the maximum per-point current rating. If the fuse blows, the module's PWR LED goes off and a Blown Fuse diagnostic is sent to the BIU.

Replacement fuses must be:

5A, 5 x 20mm slow-blow type

If the fuse blows, disconnect power, remove the module and replace the fuse. **CAUTION:** *Electrostatic discharge can damage the module when it is not installed on an I/O Terminal Block. Always observe normal ESD protection practices when handling an un-installed module.*

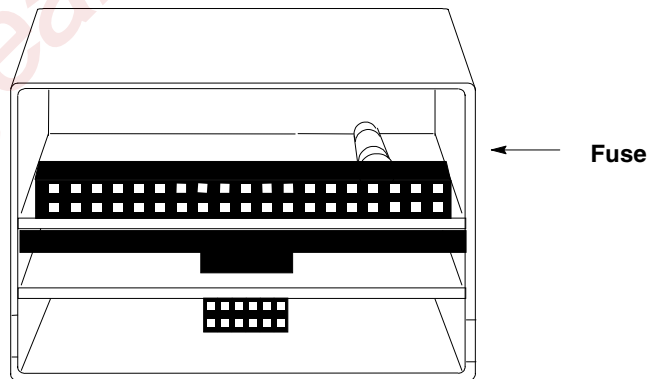

Carefully pry the fuse upward to remove it, taking care not to damage any components in the module. Place the new fuse in position and press it into the holder.

Spare fuses can be stored in the fuse holder compartment of the I/O Terminal Block (under the I/O module).

Field Wiring

The Terminal Block with box terminals has 25 terminals for each module, each of which accommodates one AWG #14 (avg 2.1mm² cross section) to AWG #22 (avg 0.36mm² cross section) wire, or two wires up to AWG #18 (avg. 0.86mm² cross section). When an external jumper is used, the wire capacity is reduced from AWG #14 (2.10mm²) to AWG #16 (1.32mm²).

The I/O Terminal Block with barrier terminals has 18 terminals per module. Each terminal can accommodate one or two wires up to AWG #14 (avg 2.1mm² cross section).

The I/O Terminal Block with Connectors has one 20-pin male connector per module. The mating connector is Amp part number 178289-8. Any tin-plated contact in the AMP D-3000 series can be used with the connector (Amp part number 1-175217-5 for high contact force receptacle for 20-24 gauge (0.20-0.56mm²) wires), 1-175218-5 for high contact force receptacle for 16-20 gauge (0.56-1.42mm²).

I/O Terminal Block wiring assignments for this module are shown below.

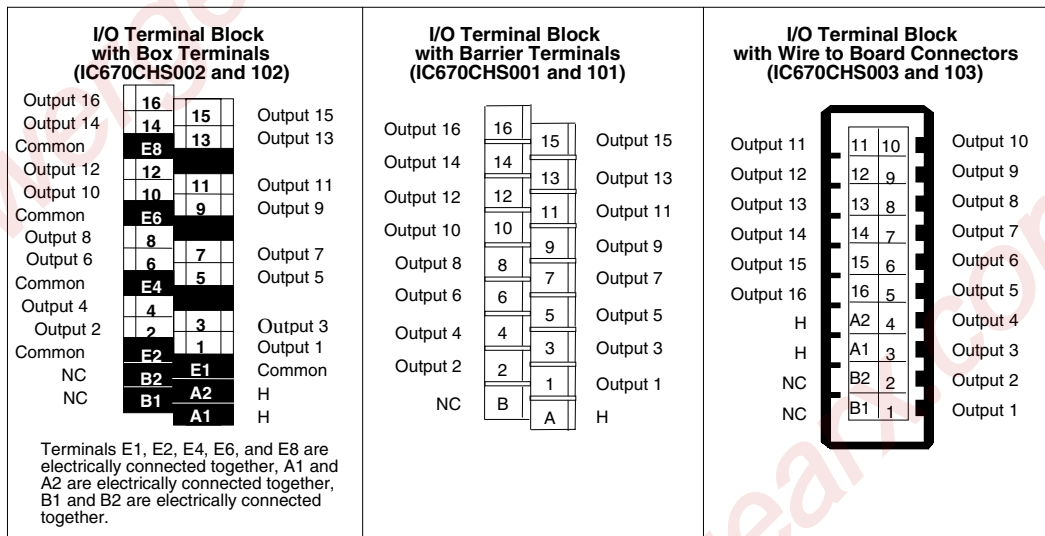

Wiring Examples with Auxiliary Terminal Blocks

If the module is installed on an I/O Terminal Block with Barrier Terminals, an Auxiliary Terminal Block can be used to provide additional wiring terminals. For the I/O Terminal Block with Wire to Board Connectors, external connection points are usually preferred, although an Auxiliary Terminal Block can be used.

Auxiliary Terminal Blocks have all terminals connected together internally. The Auxiliary Terminal Block with box terminals has 13 terminals, each of which accommodates one AWG #14 (avg 2.1mm² cross section) to AWG #22 (avg 0.36mm² cross section) wire, or two wires up to AWG #18 (avg. 0.86mm² cross section). The Auxiliary Terminal Block with barrier terminals has nine terminals, each of which can accommodate one or two wires up to AWG #14 (avg 2.1mm² cross section).

The following illustration shows how an optional Auxiliary Terminal Block with Box Terminals can be used for power connections when installing this module on an I/O Terminal Block with Box Terminals.

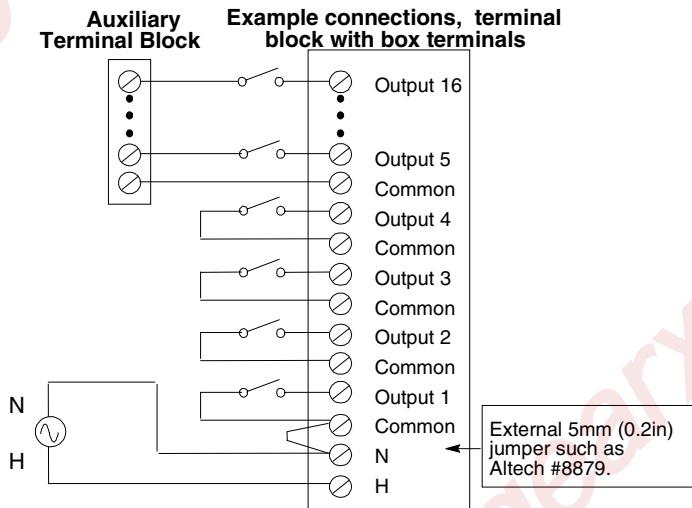

For an I/O Terminal Block with Barrier Terminals or an I/O Terminal Block with Wire to Board Connectors, an Auxiliary Terminal Block with Barrier Terminals might be connected as shown in the following example.

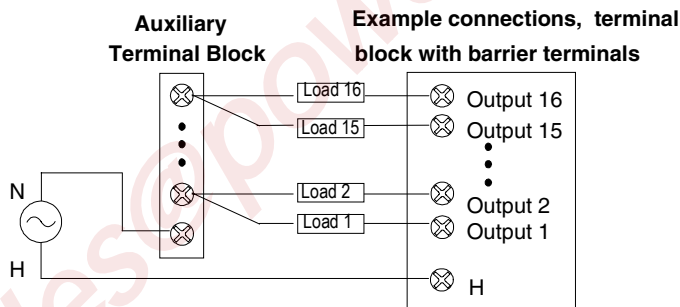

Chapter 12

120VAC Isolated 2A Discrete Output Module IC670MDL331

The 120VAC Isolated 2 Amp Output Module (IC670MDL331) provides 8 outputs arranged as four groups of 2. Each group is isolated from the others.

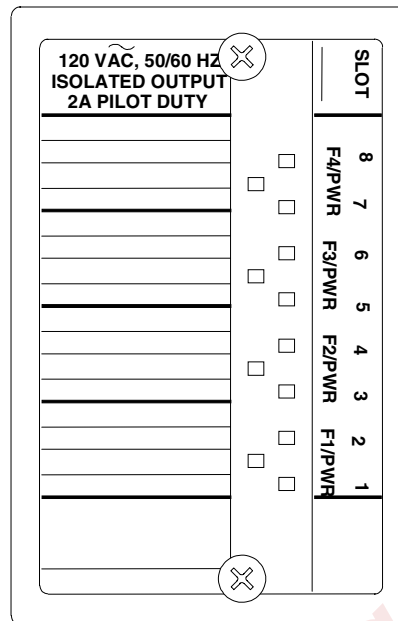

Power Sources

The power that runs the module itself comes from the power supply in the Bus Interface Unit. An external source of AC power must be provided to power the loads.

LEDs

Individual LEDs (logic side), visible through the transparent portion of the module top, indicate the on/off status of each output. The abbreviations F1/PWR, F2/PWR, F3/PWR, and F4/PWR refer to the Fuse OK LED for each of the four groups.

Host Interface

Intelligent processing for this module is performed by the Bus Interface Unit or elsewhere in the system. This includes configuring features such as output default and fault reporting. The module has 8 bits (one byte) of discrete output data. A Bus Interface Unit is required to obtain this output data from the host and/or local processor.

Module Operation

After checking the Board ID and verifying that the module is receiving appropriate logic power from the Bus Interface Unit (as reflected by the state of the module's Power LED), the Bus Interface Unit then sends output data to the module in serial format. During transmission, the module automatically loops this data back to the Bus Interface Unit for verification. The module also provides the Bus Interface Unit with the diagnostic status of the fuse on each output group.

Serial to parallel converters convert this data into the parallel format needed by the module. Optoisolators isolate the module's logic components from field outputs. Power from the external power supply is used to power the switches that drive the loads.

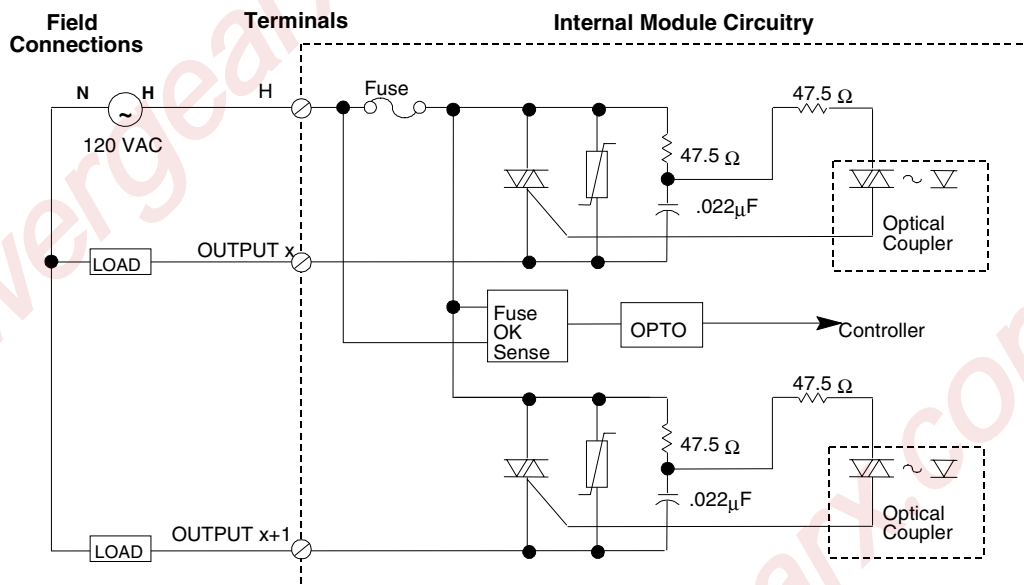

Module Specifications

Module Characteristics	
Rated Voltage	120 VAC
Output Voltage Range	85 to 132 VAC, 47 - 63 Hz
Output Current	2 amps maximum per point (2 A max. per group) 6 to 8 amps maximum per module (see Maximum Load Rating)
Outputs per module	8 (4 groups of 2 outputs each)
Indicators	Logic side LEDs indicate on/off status of each output Fuse OK LED for each of the four groups
Isolation: User input to logic, user input to frame ground, group to group	250 VAC continuous, 1500 VAC for 1 minute. No isolation between individual points in a group.
Current Drawn from Bus Interface Unit Power Supply	154 mA maximum
Output Characteristics	
Inrush Current	20A maximum for one cycle (20mS)
Maximum Load Current (resistive)	2.0 Amps from 93 VAC to 132 VAC
Minimum Load Current	10 mA per point
Output Voltage Drop	3.0 volts maximum
Output Leakage Current	2 mA at 120VAC
Response Time?On	1 ms (max)
Response Time?Off	1/2 cycle (max)
Protection (each output)	Fuse: Metric 5 x 20 mm - 3 Amp, 250 V, Slow Acting Snubber: (R=47.5 ohms, C=0.022 μ fd)

Keying Locations

Optional keying locations for the 120VAC Isolated Output Module are shown below.

Keying Locations									
A	B	C	D	E	F	G	H	J	K
	x			x	x		x		

Maximum Load Rating

The maximum rating of 2 Amp per point applies to the long term capacity of each point. Because of overall heat dissipation and current capacity of module pins, the maximum current capacity for each group is limited to 2 Amps. (Each group consists of two outputs).

The following illustration shows an example of the relationship between total module load current and ambient temperature.

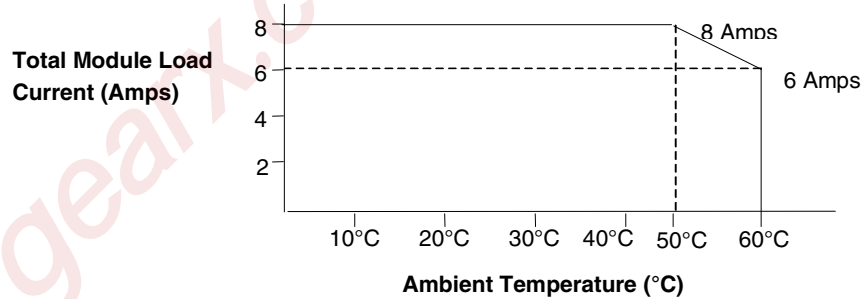

Each output on this module is capable of transiently conducting a surge current that is much greater than its long-term current rating.

The rate at which such surges can be repeated depends on the current rating of the device and the duty cycle (percent of time the device is ON). For typical incandescent devices operating at a 50% duty cycle, the following repetition rates apply:

Steady-state Current (Amps)	Repetition Rate (Hz)
0.5	5
1	1
2	0.1

Field Wiring

This module has eight outputs arranged as four groups of 2. Each group is isolated from the others. Connect each pair of output devices to a pair of Output terminals (1/2, 3/4, 5/6, 7/8) on the I/O Terminal Block. Connect the other side of the output devices to the N side of the power supply. Connect the H side of the power supply to the appropriate H terminal for the two output points.

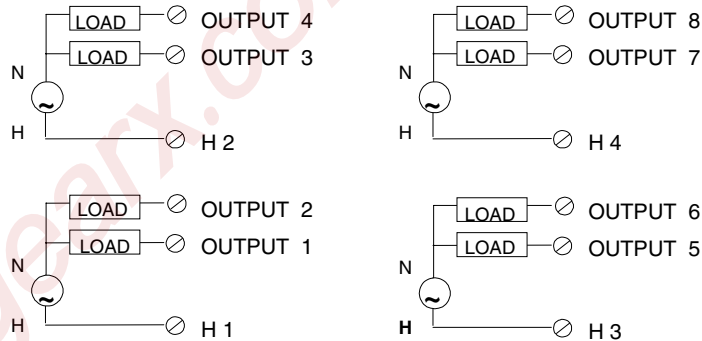

The Terminal Block with box terminals has 25 terminals for each module. Each terminal accommodates one AWG #14 (avg 2.1mm² cross section) to AWG #22 (avg 0.36mm² cross section) wire, or two wires up to AWG #18 (avg. 0.86mm² cross section). When an external jumper is used, the wire capacity is reduced from AWG #14 (2.10mm²) to AWG #16 (1.32mm²).

The I/O Terminal Block with barrier terminals has 18 terminals per module. Each terminal can accommodate one or two wires up to AWG #14 (avg 2.1mm² cross section).

The I/O Terminal Block with Connectors has one 20-pin male connector per module.

I/O Terminal Block wiring assignments for this module are shown below.

I/O Terminal Block with Box Terminals (IC670CHS002 and 102)			I/O Terminal Block with Barrier Terminals (IC670CHS001 and 101)			I/O Terminal Block with Wire to Board Connectors (IC670CHS003 and 103)				
NC	16		NC	16		Output 6	11	10	H3	
H4	14	15	H4	14	15		12	9	Output 5	
	E3	13	NC	12	13	Output 7	NC	13	8	NC
NC	12		H3	10	11	Output 6	Output 7	14	7	Output 4
H3	10	11		H3	10	Output 5	H4	15	6	H2
	E6	9		NC	8	Output 4	Output 8	16	5	Output 3
NC	8			H2	6	Output 3	NC	A2	4	NC
H2	6	7		NC	4	Output 2	NC	A1	3	Output 2
	E4	5		H1	2	Output 1	NC	B2	2	H1
NC	4			NC	4		NC	B1	1	Output 1
H1	2	3		H1	2		NC			
	E2	1		NC	4					
NC	B2	E1		H1	2					
NC	B1	A2		NC	2					
		A1		NC	B					
					A					

Terminals E1, E2, E4, E6, and E8 are electrically connected together, A1 and A2 are electrically connected together, B1 and B2 are electrically connected together.

Fusing

Each group of two outputs is fused with a 3 Amp fuse. Replacement fuses must be:

Metric 5 x 20 mm - 3 Amp, 250 V, Slow Acting

If a fuse blows, its corresponding LED goes off. In addition, the module provides a Blown Fuse diagnostic message to the BIU.

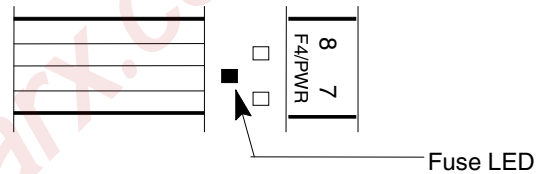

If a fuse blows, disconnect power, remove the module and replace the fuse. **CAUTION:** Electrostatic discharge can damage the module when it is not installed on an I/O Terminal Block. Always observe normal ESD protection practices when handling an un-installed module.

Fuse locations correspond to the LED positions (F1/PWR through F4/PWR) in the front of the module. See below for fuse locations.

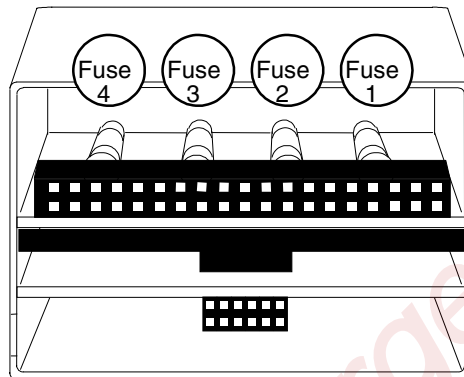

Carefully pry the fuse upward to remove it, taking care not to damage any components in the module. Place the new fuse in position and press it into the holder.

Spare fuses can be stored in the fuse holder compartment of the I/O Terminal Block (under the I/O module).

Chapter 13

24VDC Positive Logic ESCP Discrete Output Module IC670MDL730

The 24 VDC Electronic Short-Circuit Protection Output Module (IC670MDL730) provides a single group of 8 discrete outputs. Each point has electronic overcurrent and short circuit protection, and generates a fault if either condition exists.

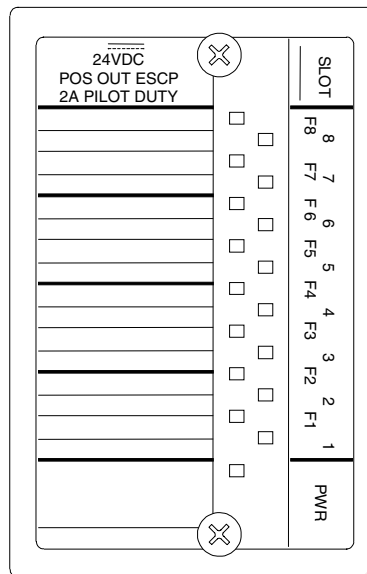

Power Sources

Power for the module itself comes from the power supply in the Bus Interface Unit. An external source of DC power must be provided for the switches that power the loads.

LEDs

Individual green LEDs (logic side) indicate the on/off status of each output. The green LEDs remain off when user power is not present, regardless of the state of the outputs. Individual yellow LEDs show the fault status of each output. The green PWR LED is on when field and backplane power are present.

Host Interface

Intelligent processing for this module is performed by the Bus Interface Unit or elsewhere in the system. This includes configuring features such as output default and fault reporting. The module has 8 bits (one byte) of discrete output data. A Bus Interface Unit is required to obtain this output data from the host and/or local processor.

Compatibility

This module must be used with a Genius Bus Interface Unit IC670GBI002 (revision 2.10) or later. This module can be used with a Profibus Bus Interface Unit or Interbus-S Bus Interface Unit version 1.0 or later.

Module Operation

After checking the Board ID, the Bus Interface Unit sends output data to the module in serial format. During transmission, the module automatically loops this data back to the Bus Interface Unit for verification. Serial to parallel converters convert this data into the parallel format needed by the module. Opto-isolators isolate the module's logic components from field outputs. Power from the external power supply is used to drive the FETs that source current to the loads.

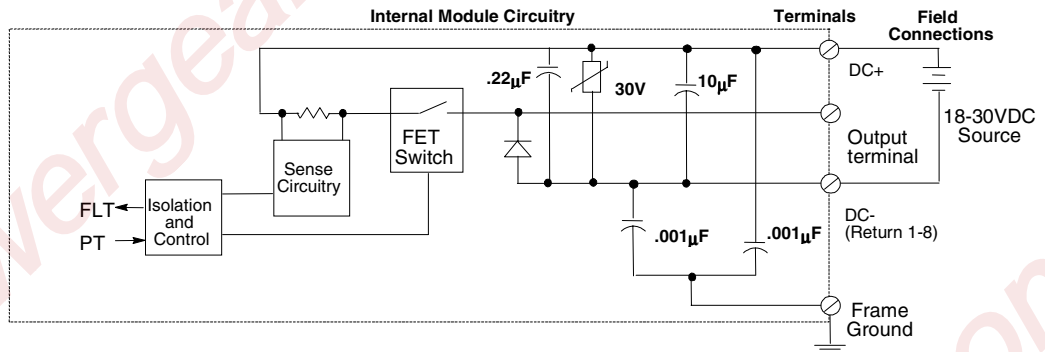

A MOV across the power supply lines protects the module from transient voltage surges. Capacitors across the supply lines and from each supply line to frame ground provide further noise protection.

Current Limit Per Point

The illustration below shows the current limits for the inrush cycle and steady-state conditions.

Built-in overcurrent protection trips if the current exceeds the specified value or duration or if the steady state current exceeds the specified value. The short circuit protection trips if the load is shorted. An automatic 1.5mS retry feature helps prevent false circuit trips caused by noise. Once an overcurrent or short circuit is detected, retry circuitry will turn the point off and back on within 1.5mS. If the problem remains, the module generates a circuit fault. The module then turns the point off, regardless of its commanded state. Both LEDs are on when a fault occurs. When a fault is present, the state of the point cannot be changed--the fault must be cleared before the point can be turned on. Faults can be cleared by sending the appropriate datagram or clearing the fault table or by cycling user power. The steady state overcurrent protection is set to trip at approximately 2.5 Amps. This protects the module from excessive currents that do not trip the short circuit protection.

Caution

Steady state current must be limited to 2 Amps per point and 8 Amps per module. Failure to observe these maximum load guidelines could result in misoperation or destruction of the module.

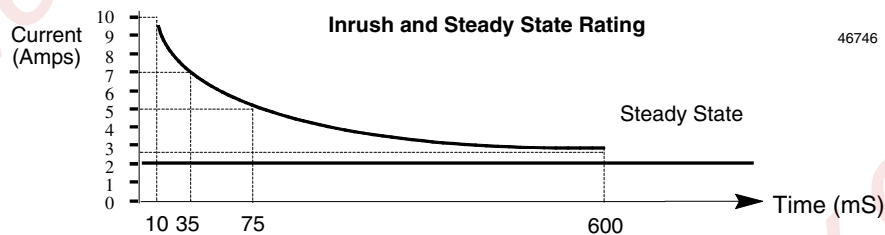

External Power Supply Requirements

The external power supply used with the module must provide sufficient field power for the module during short circuit events.

When a load is shorted, an inadequate external power supply may allow field power to drop below the specified operating range, causing misoperation of the module. The external power supply must be capable of providing short circuit energy without degradation of output voltage levels. The amount of energy required depends on the number of simultaneously-shortened points that might occur. Refer to power supply short circuit operation specifications prior to selecting the power supply to be used with the module.

Local energy storage (either batteries or capacitors) can be used to compensate for insufficient power supply characteristics.

Important Note: Additional best practices including minimizing wiring resistance from the external power supply to the module, preventing voltage drop during short circuit energy transfer.

Module Specifications

Module Characteristics	
User Input Voltage	18 - 30 VDC, 24 VDC nominal
Output Voltage Range	17.5 VDC to 29.5 VDC
Continuous Load Current	2.0 Amps maximum per point 8 Amps maximum per module
Outputs per module	8
Indicators	Individual point status (green) Individual fault status (yellow) On = fault Internal 5V status from BIU and external supply (green)
Isolation: User terminal to logic, User terminal to frame ground, Group to group	250 VAC continuous, 1500 VAC for 1 minute. No isolation between individual points in a group.
Current Drawn from Bus Interface Unit Power Supply	125 mA maximum
Output Characteristics	
Inrush Current per point	10 Amps maximum for 10mS
Steady State Overcurrent Trip Point	Nominal range 2.25 Amps - 2.75 Amps
Output Voltage Drop	0.5 volt maximum
Output Leakage Current	0.5mA at 30 VDC maximum
Response Time-On	500 μ s maximum
Response Time-Off	500 μ s maximum
Short circuit response time	20 Amps for 100 μ s
Time between retries	1.5mS maximum
Protection (each output)	Short Circuit protection, Overcurrent protection, MOV

Keying Locations

Optional keying locations for the 24 VDC Electronic Short Circuit Protection Output Module are shown below.

Keying Locations									
A	B	C	D	E	F	G	H	J	K
x		x						x	x

Field Wiring

The Terminal Block with box terminals has 25 terminals per module, each of which accommodates one AWG #14 (avg 2.1mm² cross section) to AWG #22 (avg 0.36mm² cross section) wire, or two wires up to AWG #18 (avg. 0.86mm² cross section). Using an external jumper reduces wire capacity from AWG #14 (2.10mm²) to AWG #16 (1.32mm²).

The I/O Terminal Block with barrier terminals has 18 terminals per module. Each terminal can accommodate one or two wires up to AWG #14 (avg 2.10mm² cross section).

The I/O Terminal Block with Connectors has one 20-pin male connector per module.

The following illustration shows terminal assignments for the 24 VDC Electronic Short Circuit Protection Output Module. The eight outputs form one group, with a common return.

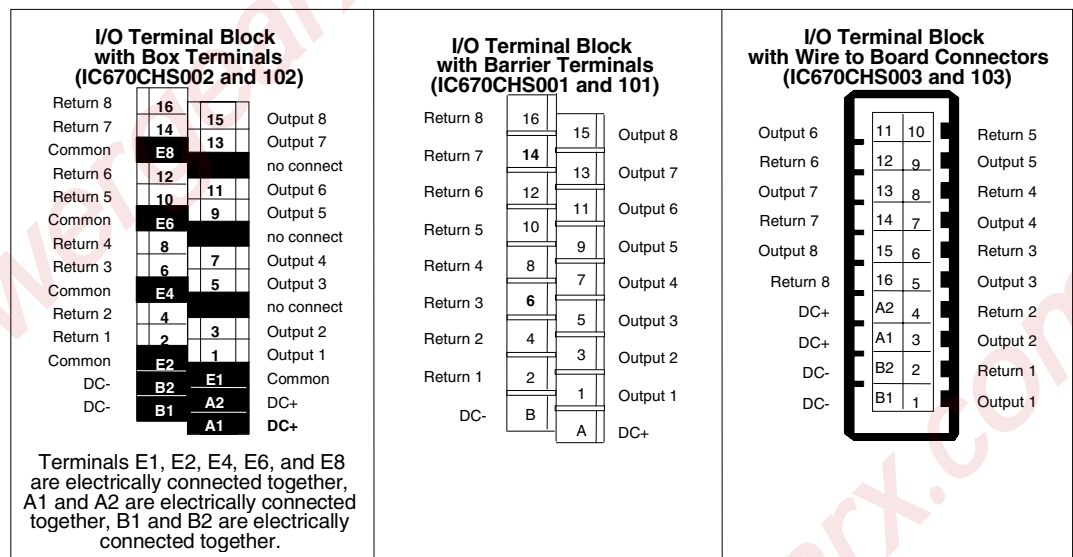

Wiring Examples with Auxiliary Terminal Blocks

The following illustration shows example module wiring to the module.

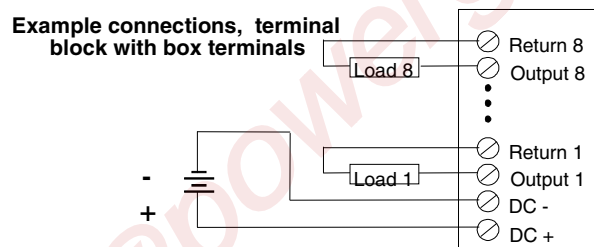

Chapter 14

12/24VDC Positive Output Module IC670MDL740

The 12/24 VDC Positive Output Module (IC670MDL740) provides a single group of 16 discrete outputs. The outputs are positive logic or sourcing-type outputs. They switch the loads to the positive side of the DC supply, and thus supply current to the load.

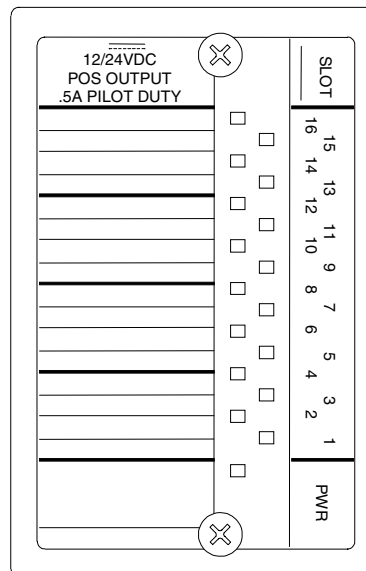

Power Sources

The power that runs the module itself comes from the power supply in the Bus Interface Unit.

An external source of DC power must be provided for the switches that power the loads. Within the module, the external power supply is connected to a 5A fuse. During operation, the module monitors this power to be sure it is above 9.8VDC. If not, it is interpreted as a fault by the BIU.

LEDs

Individual LEDs (logic side), visible through the transparent portion of the module top, indicate the on/off status of each output. The PWR LED is on when field and backplane power are present and the module fuse is not blown.

Host Interface

Intelligent processing for this module is performed by the Bus Interface Unit or elsewhere in the system. This includes configuring features such as output default and fault reporting. The module has 16 bits (two bytes) of discrete output data. A Bus Interface Unit is required to obtain this output data from the host and/or local processor.

Module Operation

After checking the Board ID and verifying that the module is receiving appropriate logic power from the Bus Interface Unit (as reflected by the state of the module's Power LED), the Bus Interface Unit then sends output data to the module in serial format. During transmission, the module automatically loops this data back to the Bus Interface Unit for verification.

Serial to parallel converters convert this data into the parallel format needed by the module. Optoisolators isolate the module's logic components from field outputs. Power from the external power supply is used to drive the FETs that source current to the loads.

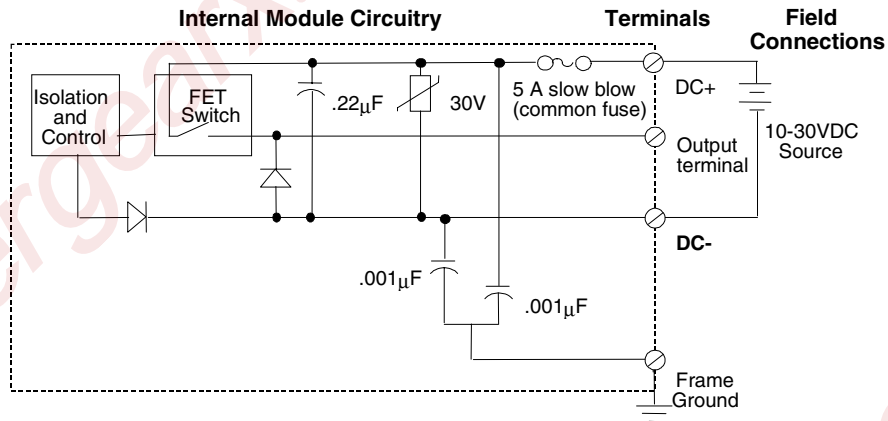

Maximum Load Rating

The outputs can switch loads over the range of 10 to 30 VDC and are capable of sourcing a maximum of 0.5A per point. The total maximum steady-state load for the entire module is 4A.

Caution

Failure to observe this maximum load guideline could result in misoperation or destruction of the module.

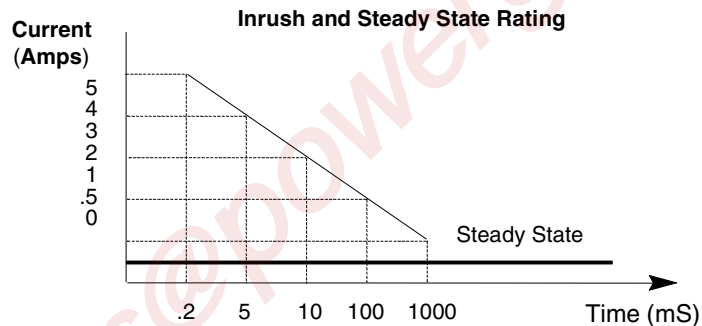

Module Specifications

Module Characteristics	
User Input Voltage	10 - 30VDC, 24VDC nominal, 4A maximum
Output Voltage Range	9.2 VDC to 29.5 VDC
Output Current	0.5 Amps maximum per point 4 Amps maximum per module
Outputs per module	16
Indicators	Logic side LEDs indicate on/off status of each output; blown fuse fault and user supply below 9.8VDC.
Isolation: User input to logic, user input to frame ground, group to group	250 VAC continuous, 1500 VAC for 1 minute. No isolation between individual points in a group.
Current Drawn from Bus Interface Unit Power Supply	111 mA maximum
Output Characteristics	
Inrush Current	2A maximum for 100ms (see Inrush and Steady State Rating diagram)
Maximum Load Current (resistive)	0.5 Amps from 10 VDC to 30 VDC
Minimum Load Current	1 mA per point
Output Voltage Drop	0.5 volts maximum
Output Leakage Current	0.5 mA at 30 VDC
Response Time-On	200 μ s maximum with 0.5A resistive load
Response Time-Off	200 μ s maximum with 0.5A resistive load
Protection (each output)	Fuse: -Metric 5 x 20 mm - 5 Amp, 250 V, Slow Acting Common to all outputs

Module Fuse

The module's 5 Amp fuse protects outputs against the effects of polarity reversal of the external power supply or excessive current through the output points.

If incorrect connection of the power supply blows the fuse, it is indicated by the module's LED. In addition, the module provides a Blown Fuse diagnostic message to the BIU. If the fuse blows, disconnect power, remove the module and replace the fuse. *CAUTION: Electrostatic discharge can damage the module when it is not installed on an I/O Terminal Block. Always observe normal ESD protection practices when handling an un-installed module.*

Fuse location is shown below. Pry the fuse upward to remove it, taking care not to damage any components in the module. Place the new fuse in position and press it into the holder.

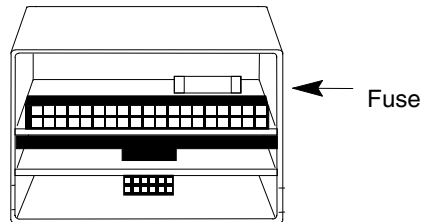

Spare fuses can be stored in the fuse holder compartment of the I/O Terminal Block (under the I/O module). The fuse should be a 5A, 5x20mm 250VAC slow-blow type.

Keying Locations

Optional keying locations for the 12/24 VDC Positive Output Module are shown below.

Keying Locations									
A	B	C	D	E	F	G	H	J	K
x		x						x	x

Field Wiring

The Terminal Block with box terminals has 25 terminals for each module, each of which accommodates one AWG #14 (avg 2.1mm² cross section) to AWG #22 (avg 0.36mm² cross section) wire, or two wires up to AWG #18 (avg. 0.86mm² cross section). When an external jumper is used, the wire capacity is reduced from AWG #14 (2.10mm²) to AWG #16 (1.32mm²).

The I/O Terminal Block with barrier terminals has 18 terminals per module. Each terminal can accommodate one or two wires up to AWG #14 (avg 2.1mm² cross section).

The I/O Terminal Block with Connectors has one 20-pin male connector per module.

The following illustration shows terminal assignments for the 12/24 VDC Positive Output Module.

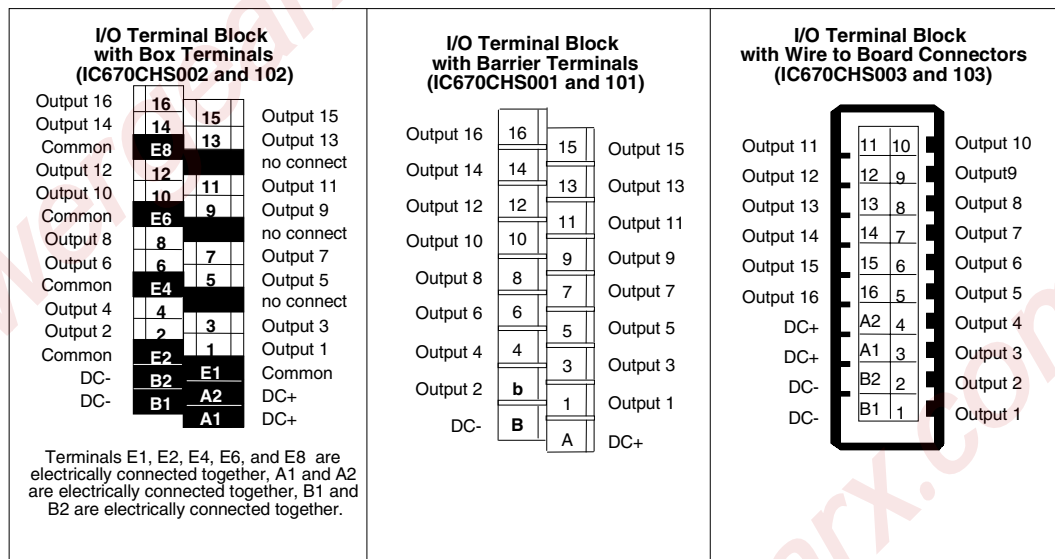

Wiring Examples with Auxiliary Terminal Blocks

If the module is installed on an I/O Terminal Block with Barrier Terminals, an Auxiliary Terminal Block can be used to provide additional wiring terminals. For the I/O Terminal Block with Wire to Board Connectors, external connection points are usually preferred, although an Auxiliary Terminal Block can be used..

Auxiliary Terminal Blocks have all terminals connected together internally. The Auxiliary Terminal Block with box terminals has 13 terminals, each of which accommodates one AWG #14 (avg 2.1mm² cross section) to AWG #22 (avg 0.36mm² cross section) wire, or two wires up to AWG #18 (avg. 0.86mm² cross section). The Auxiliary Terminal Block with barrier terminals has nine terminals, each of which can accommodate one or two wires up to AWG #14 (avg 2.1mm² cross section).

The following illustration shows how an optional Auxiliary Terminal Block with Box Terminals can be used for power connections when installing this module on an I/O Terminal Block with Box Terminals.

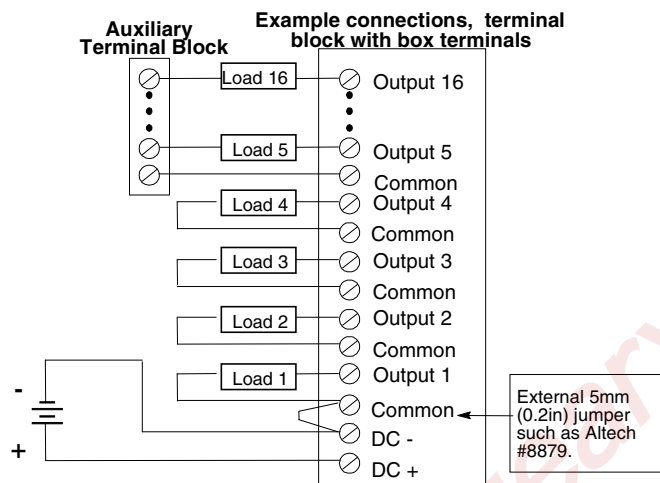

For an I/O Terminal Block with Barrier Terminals or an I/O Terminal Block with Wire to Board Connectors, an Auxiliary Terminal Block with Barrier Terminals might be connected as shown in the following example.

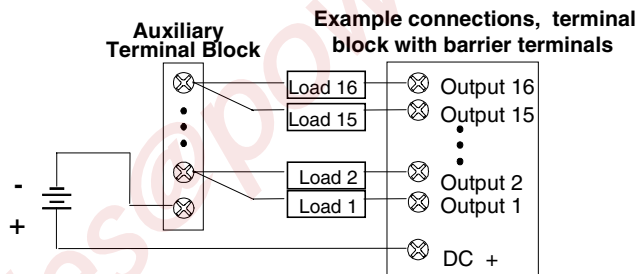

Chapter 15

5/12/24VDC Negative Output Module IC670MDL742

The 5/12/24 VDC Negative Output Module (IC670MDL742) provides a single group of 16 discrete outputs. The outputs are negative logic or current-sinking outputs. They switch the loads to the negative side of the DC supply, and thus sink current through the load.

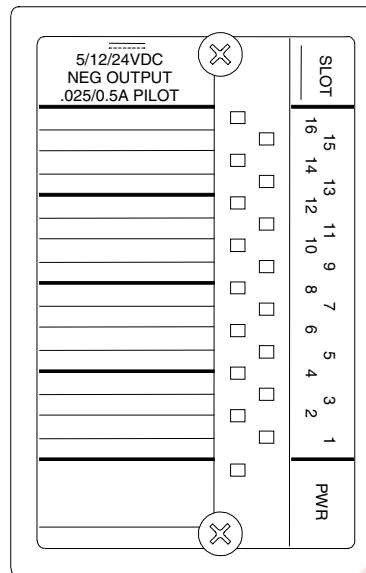

Power Sources

The power for the module itself comes from the power supply in the Bus Interface Unit. An external source of DC power must be provided for the switches that power the loads. Within the module, the external power supply is connected to a 10 Amp fuse. During operation, the module monitors this power to be sure it is above 4.2 VDC. If not, it is interpreted as a fault by the Bus Interface Unit.

LEDs

Individual LEDs (logic side), visible through the transparent portion of the module top, indicate the on/off status of each output. The PWR LED is on when field and backplane power are present and the module fuse is not blown.

Host Interface

Intelligent processing for this module is performed by the Bus Interface Unit or elsewhere in the system. This includes configuring features such as output default and fault reporting. The module has 16 bits (two bytes) of discrete output data. A Bus Interface Unit is required to obtain this output data from the host and/or local processor.

Module Operation

After checking the Board ID and verifying that the module is receiving appropriate logic power from the Bus Interface Unit (as reflected by the state of the module's Power LED), the Bus Interface Unit then sends output data to the module in serial format. During transmission, the module automatically loops this data back to the Bus Interface Unit for verification.

Serial to parallel converters convert this data into the parallel format needed by the module. Opto-isolators isolate the module's logic components from field outputs. Power from the external power supply is used to drive the FETs that source current to the loads.

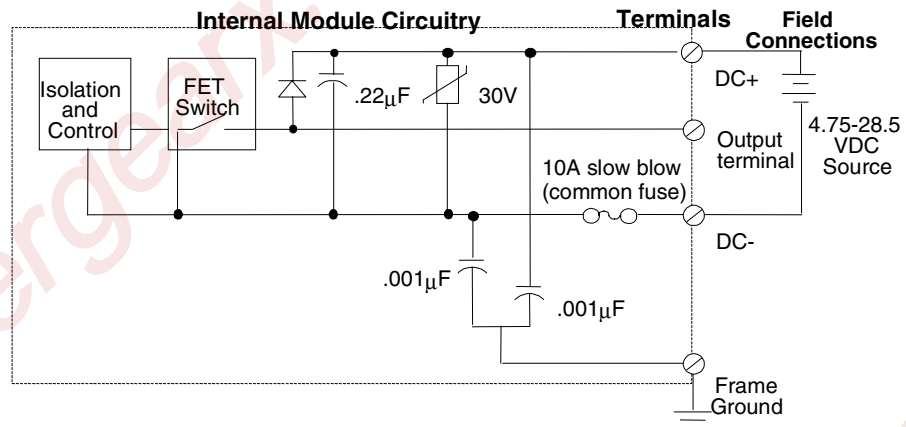

Maximum Load Rating

The outputs can switch loads over the range of 4.5 to 28.5 VDC and are capable of sinking up to a maximum of 0.5 Amp per point. The total maximum steady-state load for the entire module is 8 Amps.

Caution

Failure to observe this maximum load guideline could result in misoperation or destruction of the module.

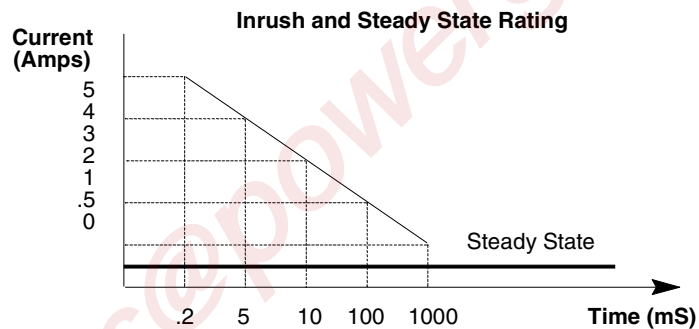

Module Specifications

Module Characteristics	
User Input Voltage	4.75 - 5.25 / 10.5 - 28.5 VDC, 8A maximum
Output Voltage Range	4.5 VDC to 28.25 VDC
Output Current	25mA maximum for 5-volt operation, 0.5 Amp maximum for 10.5 - 28.5 volt operation 8 Amps maximum per module 0.025A pilot duty at 4.75-5.25 VDC 0.5A pilot duty at 10.5-28.5 VDC
Outputs per module	16
Indicators	PWR LED indicates backplane power. Logic side LEDs indicate on/off status of each output; blown fuse fault and user supply below 4.2 VDC.
Isolation: User input to logic, user input to frame ground, group to group	250 VAC continuous, 1500 VAC for 1 minute. No isolation between individual points in a group.
Current Drawn from Bus Interface Unit Power Supply	111 mA maximum
Output Characteristics	
Inrush Current	2A max. for 100mS (see Inrush and Steady State diagram)
On state voltage: -5 volts -10.5 - 28.5 volts	0.25V maximum at 25mA maximum 0.25V maximum at 0.5 Amp maximum
Minimum Load Current	1 mA per point
Output Voltage Drop	0.25 volts maximum at rated currents
Output Leakage Current	250 μ A at 28.5 VDC
Response Time-On	200 μ s maximum with 0.5A resistive load
Response Time-Off	200 μ s maximum with 0.5A resistive load
Protection (each output)	Fuse: Metric 5 x 20 mm - 10 Amp, 250 V, Slow Acting Common to all outputs

Module Fuse

The module's 10 Amp fuse protects outputs against the effects of polarity reversal of the external power supply or excessive current through the output points. If incorrect connection of the power supply blows the fuse, it is indicated by the module's PWR LED. In addition, the module provides a Blown Fuse diagnostic message to the BIU. IF the fuse blows, disconnect power, remove the module and replace the fuse. *CAUTION: Electrostatic discharge can damage the module when it is not installed on an I/O Terminal Block. Always observe normal ESD protection practices when handling an un-installed module.*

Fuse location is shown below. Pry the fuse upward to remove it, taking care not to damage any components in the module. Place the new fuse in position and press it into the holder.

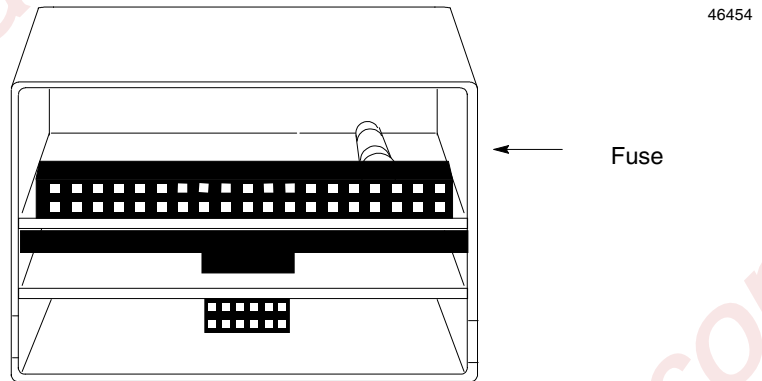

Keying Locations

Optional keying locations for the 5/12/24 VDC Negative Output Module are shown below.

Keying Locations									
A	B	C	D	E	F	G	H	J	K
x	x						x		x

Field Wiring

The Terminal Block with box terminals has 25 terminals for each module, each of which accommodates one AWG #14 (avg 2.1mm² cross section) to AWG #22 (avg 0.36mm² cross section) wire, or two wires up to AWG #18 (avg. 0.86mm² cross section). When an external jumper is used, the wire capacity is reduced from AWG #14 (2.10mm²) to AWG #16 (1.32mm²).

The I/O Terminal Block with barrier terminals has 18 terminals per module. Each terminal can accommodate one or two wires up to AWG #14 (avg 2.1mm² cross section).

The I/O Terminal Block with Connectors has one 20-pin male connector per module.

The following illustration shows terminal assignments for the 15/2/24 VDC Negative Output Module.

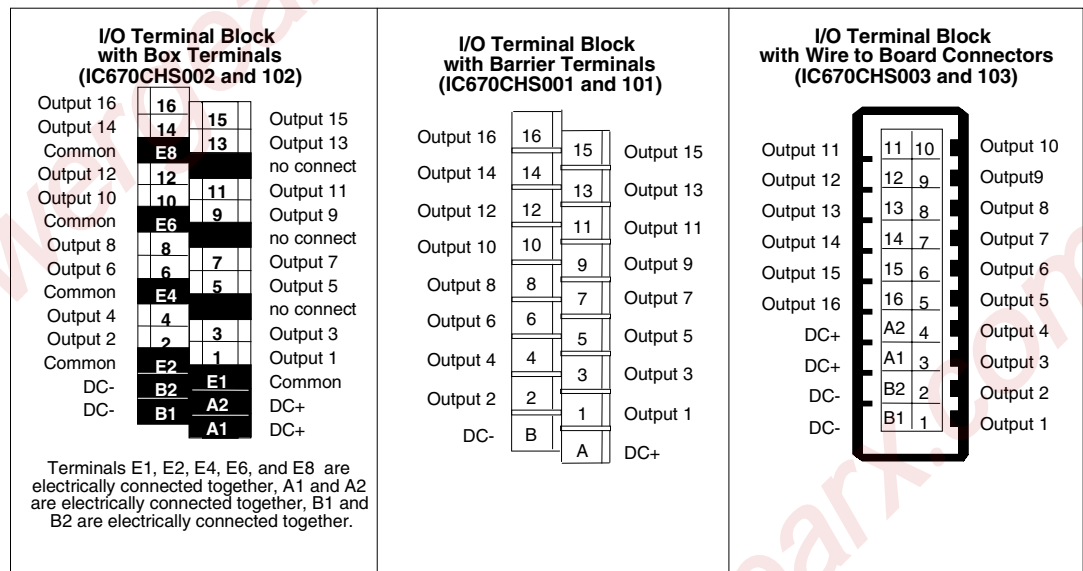

Wiring Examples with Auxiliary Terminal Blocks

If the module is installed on an I/O Terminal Block with Barrier Terminals, an Auxiliary Terminal Block can be used to provide additional wiring terminals. For the I/O Terminal Block with Wire to Board Connectors, external connection points are usually preferred, although an Auxiliary Terminal Block can be used..

Auxiliary Terminal Blocks have all terminals connected together internally. The Auxiliary Terminal Block with box terminals has 13 terminals, each of which accommodates one AWG #14 (avg 2.1mm² cross section) to AWG #22 (avg 0.36mm² cross section) wire, or two wires up to AWG #18 (avg. 0.86mm² cross section). The Auxiliary Terminal Block with barrier terminals has nine terminals, each of which can accommodate one or two wires up to AWG #14 (avg 2.1mm² cross section).

The following illustration shows how an optional Auxiliary Terminal Block with Box Terminals can be used for power connections when installing this module on an I/O Terminal Block with Box Terminals.

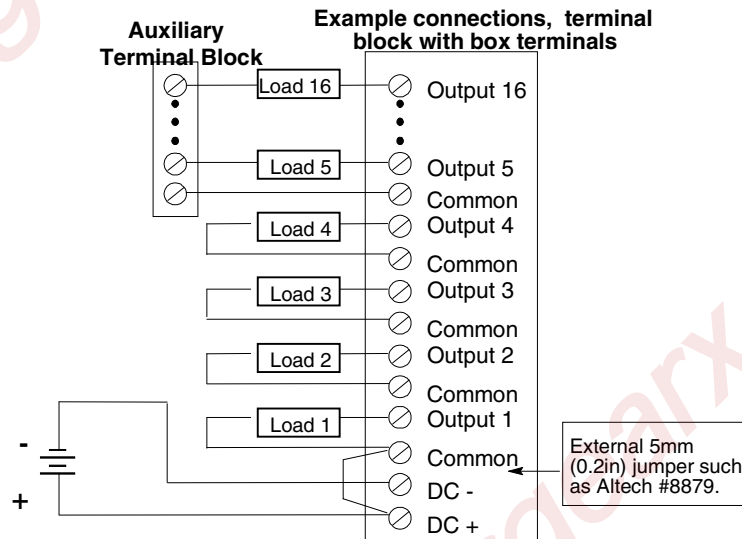

For an I/O Terminal Block with Barrier Terminals or an I/O Terminal Block with Wire to Board Connectors, an Auxiliary Terminal Block with Barrier Terminals might be connected as shown in the following example.

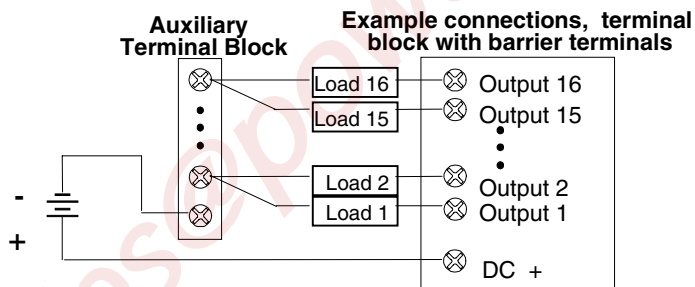

Chapter 16

Relay Isolated NO/NC Output Module IC670MDL930

The Isolated, NO/NC Relay Output Module (IC670MDL930) provides eight isolated outputs. The outputs consist of six normally–open (Form A) contacts and two normally–open or normally–closed (Form C) contacts. Six form ‘A’ relays provide the NO outputs while two form ‘C’ relays provide the NO/NC points.

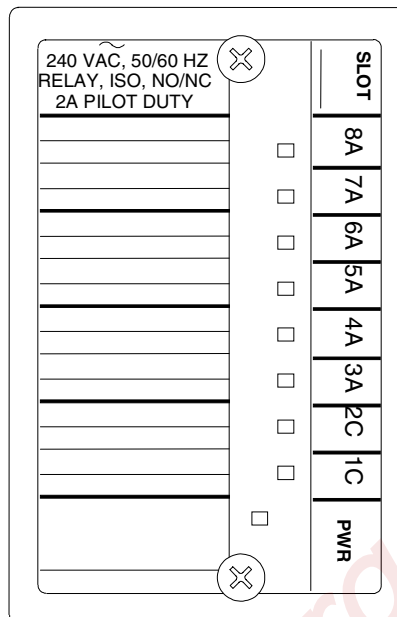

Power Sources

The power that runs the module itself comes from the power supply in the Bus Interface Unit. An external source of AC and/or DC power must be provided for the loads driven by the contacts.

LEDs

Individual LEDs (logic side), visible through the transparent portion of the module top, indicate the on/off status of each output. The PWR LED is on when backplane power is present.

Host Interface

Intelligent processing for this module is performed by the Bus Interface Unit or elsewhere in the system. This includes configuring features such as output default and fault reporting. The module has 8 bits (one byte) of discrete output data. A Bus Interface Unit is required to obtain this output data from the host and/or local processor.

Module Operation

After checking the Board ID and verifying that the module is receiving appropriate logic power from the Bus Interface Unit (as reflected by the state of the module's Power LED), the Bus Interface Unit then sends output data to the module in serial format. During transmission, the module automatically loops this data back to the Bus Interface Unit for verification.

Serial to parallel converters convert this data into the parallel format needed by the module. Opto-isolators isolate the module's logic components from field outputs. Power from the external power supply is used to power the loads connected to the contacts.

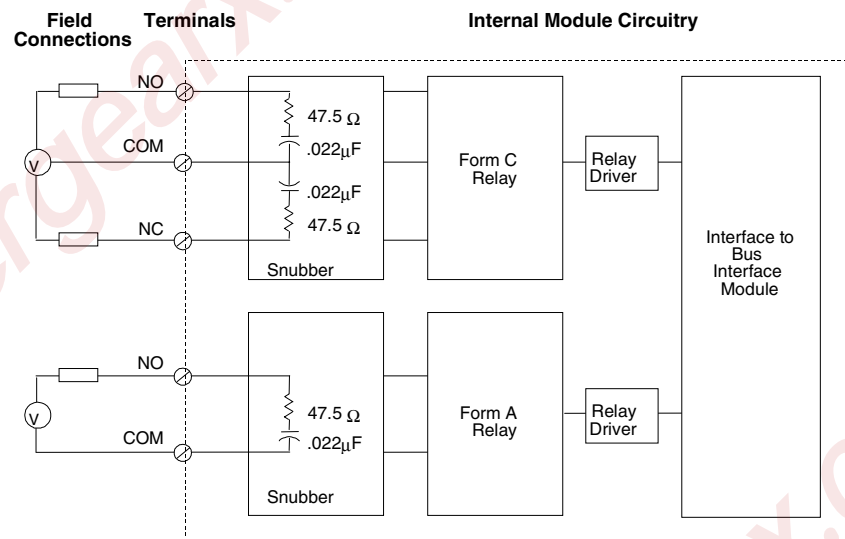

Maximum Load Rating

The resistive rating of the module is 2 amps per point at 120/240 VAC or 24 VDC and 0.2 amps per point for 125 VDC. Power to energize the relay coils is supplied by the module. An RC snubber is used across the contacts.

Suppression

Each output is suppressed with an RC snubber to reduce high frequency noise transients. Proper suppression of the switched load is still recommended and will contribute to improved system reliability. *Suppression at the load will not only lengthen contact life, but will also reduce noise transients in the control wiring.*

Module Specifications

Module Characteristics	
Configuration	6 points – Form A (each point isolated) 2 points – Form C (each point isolated)
Rated Voltage	5/24/125 VDC, 120/240 VAC
Voltage Range	0-130 VDC, 0-265 VAC (47-63 Hz)
Maximum Load Current (resistive)	16 amps per module
Indicators	Individual logic side LEDs indicate the status of each output. The PWR LED indicates the presence of backplane power.
Isolation: User input to logic, user input to frame ground, group to group	250 VAC continuous, 1500 VAC for 1 minute. No isolation between individual points in a group.
Relay Type	Fixed coil, moving armature
Current Drawn from BIU Power Supply	313 mA maximum (see chart on the next page)
Output Characteristics	
Maximum Load Current (resistive)	2.0 Amps from 5 to 265VAC 2.0 Amps from 5 to 30VDC 0.2 Amps from 31 to 125VDC
Maximum Inrush	5 Amps for 20mS
Minimum Load Current	10 mA per point
Output Leakage	2 mA at 120 VAC maximum
Response Time–On	10 ms (max)
Response Time–Off	10 ms (max)
Switching Frequency	20 cycles/minute (inductive load)
Contact Type	Silver Alloy
Contact Resistance	0.2 (initial) at 1 A, 6 VDC
Contact Life	Mechanical: 20 x 10 ⁶ operations Electrical: 10 ⁵ operations at rated resistive load
Protection (each output)	Snubber (R=47.5 ohms, C=0.022 ufd). No fuse
Vibration (this module)	IEC68–2–6: 10 to 57 Hz 0.012in displacement (peak to peak) -57 to 500 Hz at 1.5 G-

BIU Power Drain per Point

The Relay Output Module's BIU power requirement increases as the number of points that are simultaneously on increases. The chart below shows the relationship between the power required and the number of points that are on.

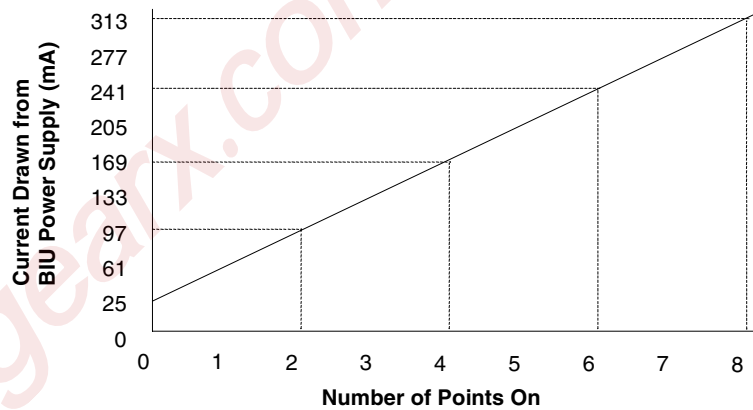

Typical Contact Life versus Load Conditions

Operating Voltage	Maximum Current for Load Type		Typical Contact Life (number of operations)
	Resistive	Inductive *	
24 - 120 VAC	2.0 Amp	1.0 Amp	300,000
24 - 120 VAC	-	2.0 Amp	150,000
24 - 120 VAC	1.0 Amp	0.5 Amp	500,000
24 - 120 VAC	0.1 Amp	0.05 Amp	1,000,000
240 VAC	2.0 Amp	1.0 Amp	150,000
240 VAC	-	2.0 Amp	50,000
240 VAC	1.0 Amp	0.5 Amp	200,000
240 VAC	0.1 Amp	0.05 Amp	500,000
24 VDC	2.0 Amp	1.0 Amp	300,000
24 VDC	-	2.0 Amp	100,000
24 VDC	1.0 Amp	0.5 Amp	500,000
24 VDC	0.1 Amp	0.05 Amp	1,000,000

* Power Factor = 0.4 minimum for AC inductive loads
Time Constant - 7mS for DC inductive loads

Keying Locations

Optional keying locations for the Isolated, NO/NC, Relay Output Module are shown below:

Keying Locations									
A	B	C	D	E	F	G	H	J	K
		x	x	x	x	x	x		

Field Wiring

The diagram below shows input and power connections for the module's two normally-open or normally-closed (Form C) contacts (labeled 1C and 2C on the module) and six normally-open (Form A) contacts (labeled 3A, 4A, 5A, 6A, 7A, and 8A).

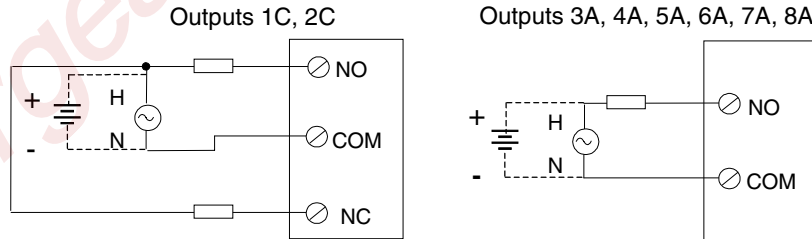

I/O Terminal Block wiring assignments for this module are shown below.

Note: COM 1 through COM 8 may be connected together if a single supply is required. However, the maximum current through any one terminal may not exceed 10 Amps.

I/O Terminal Block with Box Terminals (IC670CHS002 and 102)		I/O Terminal Block with Barrier Terminals (IC670CHS001 and 101)		I/O Terminal Block with Wire to Board Connectors (IC670CHS003 and 101)	
Com 8A	16	NO 8A	15	NO 6A	11
Com 7A	14	NO 7A	13	Com 6A	12
	E8			NO 7A	9
Com 6A	12	NO 6A	11	Com 7A	14
Com 5A	10	NO 5A	9	NO 8A	15
	E6			Com 3A	16
Com 4A	8	NO 4A	7	Com 8A	5
Com 3A	6	NO 3A	5	Com 1C	4
	E4			Com 1C	A1
NO 2C	4	NO 1C	3	Com 2C	3
NC 2C	2	NC 1C	1	Com 1C	A2
	E2			Com 2C	B2
Com 2C	B2	Com 1C	1	Com 2C	B1
Com 2C	B1	Com 1C	A		1

Terminals E1, E2, E4, E6, and E8 are electrically connected together. A1 and A2 are electrically connected together. B1 and B2 are electrically connected together.

Chapter 17

24 VDC Mixed Discrete Input/Output Module IC670MDD441

The 24 VDC Mixed Input/Output Module with Electronic Short-Circuit Protection (IC670MDD441) provides 10 discrete input circuits and 6 discrete output circuits sharing the same common line. Each output point has electronic overcurrent and short circuit protection, and generates a fault if either condition exists.

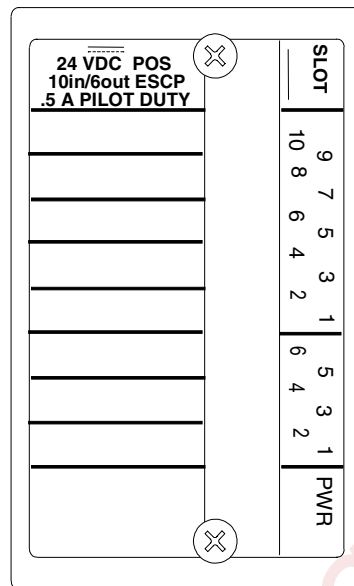

An overcurrent or short-circuit fault on an output point causes the point to turn off. A module fault is reported to the BIU.

Power Sources

Power for the module itself comes from the power supply in the Bus Interface Unit. An external source of DC power must be provided for the switches that power the loads. The common line on DC power is also the return for the input circuits.

LEDs

Individual logic side LEDs indicate the presence of input voltage for each input point (green = ON).

A logic side bi-color LED for each output indicates that an output circuit is ON (green) or that a fault condition has occurred (orange). The green LEDs will continue to operate when user power is not present. If a point fault occurs, the point is automatically turned OFF. The fault is cleared by sending a clear command from the HHM or by cycling power on either the backplane or the user side.

The PWR LED indicates logic and user power is available to operate the module (green = OK, OFF = loss of power).

Host Interface

Intelligent processing for this module is performed by the Bus Interface Unit or elsewhere in the system. The module uses 16 discrete input data bits (two bytes) and 8 discrete output data bits (one byte). The remaining 6 unused input data bits and 2 unused output data bits are not used. A Bus Interface Unit is required to exchange this I/O data in a byte format with the host and/or a local processor.

Compatibility

This module must be used with a Genius Bus Interface Unit IC670GBI002 (revision 2.20) or later. This module can be used with a Profibus Bus Interface Unit or Interbus-S Bus Interface Unit version 2.20 or later.

Module Operation

After checking the Board ID, the Bus Interface Unit sends output data to the module and receives input data from the module. Input, output, and Board ID data are in serial format. During transmission, the module automatically loops output data back to the Bus Interface Unit for verification. A serial to parallel conversion converts output data into the parallel format needed by the module. Conversely, a parallel to serial conversion converts input data into the serial format needed by the BIU. Opto-isolators isolate the module's inputs and outputs from the field. Power from the external power supply is used to drive the FET switches that source current to the loads.

Input Circuit

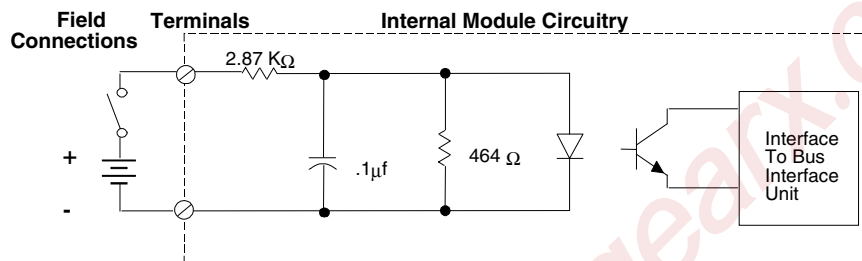

Output Circuit

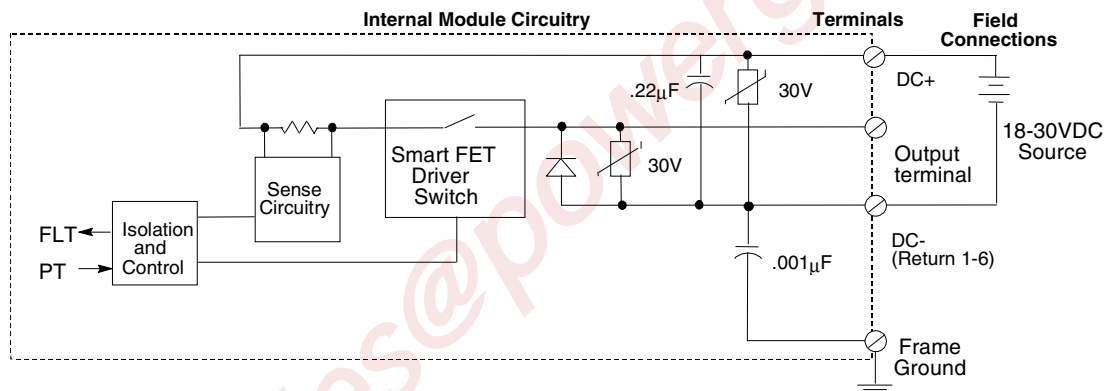

A MOV across the power supply lines protects the module from transient voltage surges. Capacitors across the supply lines and from each supply line to frame ground provide further noise protection.

External Power Supply Requirements

The external power supply used with the module must provide sufficient field power for the module during short circuit events.

When a load is shorted, an inadequate external power supply may allow field power to drop below the specified operating range, causing misoperation of the module. The external power supply must be capable of providing short circuit energy without degradation of output voltage levels. The amount of energy required depends on the number of simultaneously-short-circuited points that might occur. Refer to power supply short circuit operation specifications prior to selecting the power supply to be used with the module.

Local energy storage (either batteries or capacitors) can be used to compensate for insufficient power supply characteristics.

Important Note: Additional best practices including minimizing wiring resistance from the external power supply to the module, preventing voltage drop during short circuit energy transfer.

Module Specifications

Input Circuits	
Rated Input Voltage	24 VDC
Inputs per module	10 Pos/Neg Logic Inputs
Input Voltage Range	0 to +30 VDC
User Input Current	8.0mA per point @ 24 VDC
Isolation to case, ground, logic side	250 VAC continuous, 1500 VAC for 1 minute. No isolation between individual points in a group.
Indicators	1 LED per point shows individual point status
Input Impedance	2.87k typical
On-state voltage	+15 VDC to +30 VDC
OFF-state voltage	0 to +5 VDC
On-state current	3.0 mA to 8.0 mA
OFF-state current	0 to 1.5 mA
Response Time-On	25µs typical, 60µs maximum
Response Time-Off	100µs typical, 150µs maximum
Output Circuits	
Rated Output Voltage	24 VDC
Output Voltage Range	15 VDC to 30 VDC
Output Current	0.5 A maximum per point
Outputs per module	6
Indicators	1 Bi-color LED per point indicating on/off status of output circuits (green) and short/over current circuit fault (orange)
Isolation to case, ground, logic side	250 VAC continuous, 1500 VAC for 1 minute. No isolation between individual points in a group.
Steady State Overcurrent Trip Point	1.6 A typical, 0.7 A to 2.5 A max range
Maximum Load Current (resistive)	0.5 A @ 30 VDC
Output Voltage Drop	0.2 V maximum
Output Leakage Current	0.5 mA @ 30 VDC maximum
Response Time-On	100µs typical, 150µs maximum
Response Time-Off	400µs typical, 500µs maximum
Protection (each output)	short circuit protection, over current protection, MOV and freewheeling diodes
Input/Output Circuits	
Total Current Drawn from BIU	110mA
Indicators backplane	PWR LED indicates field and backplane power are present

Keying Locations

Optional keying locations for the 24 VDC Mixed Input/Output Module are shown below.

Keying Locations									
A	B	C	D	E	F	G	H	J	K
x		x				x	x		

Field Wiring

The Terminal Block with box terminals has 25 terminals per module, each of which accommodates one AWG #14 (avg 2.1mm² cross section) to AWG #22 (avg 0.36mm² cross section) wire, or two wires up to AWG #18 (avg. 0.86mm² cross section). Using an external jumper reduces wire capacity from AWG #14 (2.10mm²) to AWG #16 (1.32mm²).

The I/O Terminal Block with barrier terminals has 18 terminals per module. Each terminal can accommodate one or two wires up to AWG #14 (avg 2.10mm² cross section).

The I/O Terminal Block with Connectors has one 20-pin male connector per module.

The following illustration shows terminal assignments for the 24 VDC Electronic Short Circuit Protection Output Module. The eight outputs form one group, with a common return.

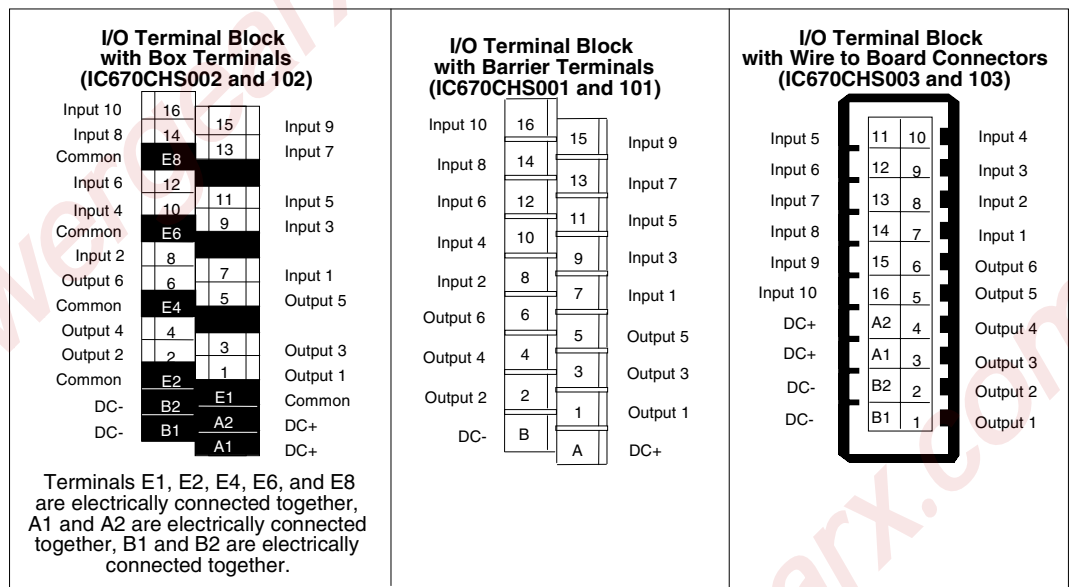

Wiring Example

The following illustration shows example wiring to the module.

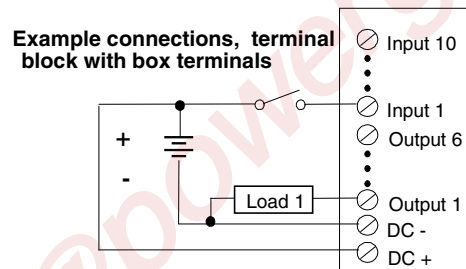

Discrete Input/Output Module

24VDC Mixed Discrete Input/Output Module

GFK-1486
August 1997

Chapter 18

Current Source Analog Input Module IC670ALG230

The Current Source Analog Input Module (IC670ALG230) accommodates 8 inputs on a common power supply.

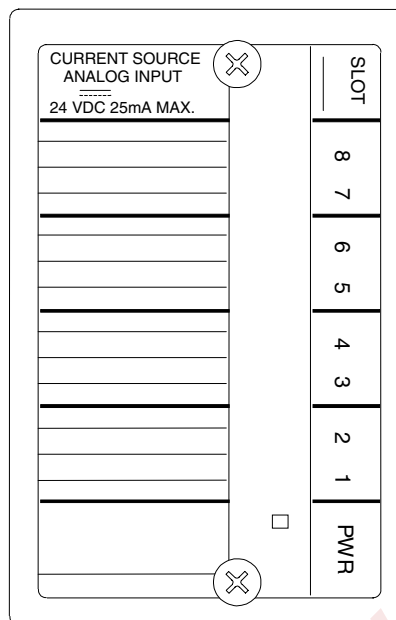

Power Sources

The same 24 volt power supply used for the Bus Interface Unit can provide loop power in most cases. Separate power supply(s) must be used if isolation between circuits is required. The most common application uses a loop supply local at the module to drive multiple isolated transducers, isolated analog inputs, or differential analog inputs.

LED

An LED, visible through the transparent portion of the module top, is on when both backplane and field power are present, and the fuse is not blown.

Host Interface

The Current-Source Analog Input Module converts current levels to unscaled analog input data. Analog scaling is performed by the Bus Interface Unit, which provides the scaled data to the host. Software Range selections of 0 to 20 mA and 4 to 20 mA are configurable on a per-channel basis. The default range is 0 to 20 mA. The default scaling for the module is:

Eng Lo	=	0
Eng Hi	=	20,000
Int Lo	=	0
Int Hi	=	20,000

The module has 8 words (16 bytes) of analog input data. A Bus Interface Unit is required to provide this input data to the host and/or local processor.

Module Operation

The 250 ohm resistor converts input current to a voltage with respect to common. The input R-C filters high-frequency noise, while the opamp buffers the signal to the analog/digital converter. All eight +24 VDC Out terminals are common to each other. The chassis ground goes to the I/O Terminal Block ground terminal.

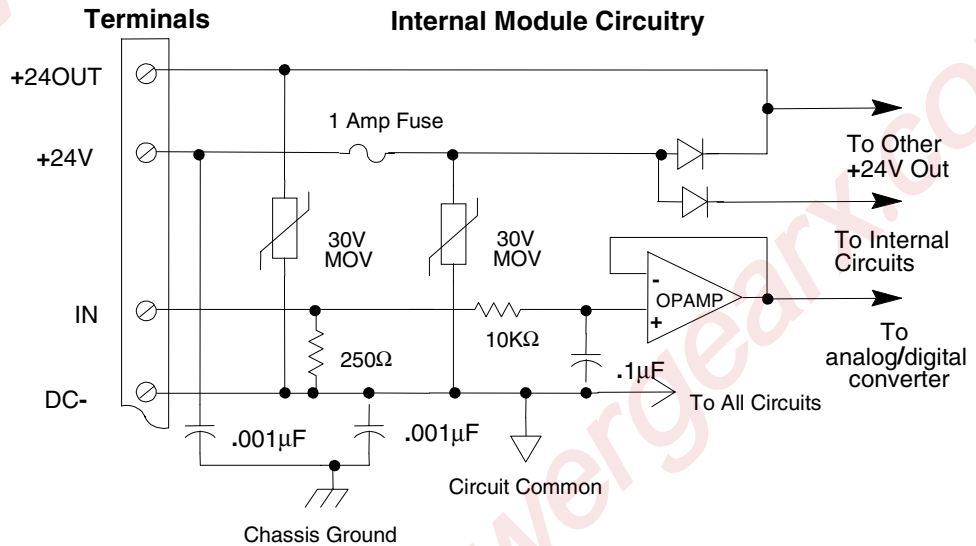

Module Specifications

Module Characteristics	
Input or channel to channel common mode	None; single ended grouped input
Power supply voltage, including minimum/maximum ripple	18 Volts minimum 24 Volts typical 30 Volts maximum
24V Power input current Module only Including loop	50 mA minimum 210 mA (including loop current), maximum
Isolation to ground and logic	1500 VAC for 1 minute, 250 VAC continuous.
Current drawn from BIU power supply	51mA maximum
Input Characteristics	
Digital Resolution	12 bits, typical
Analog Resolution	5.0 microAmps
Input current span	0.1 mA minimum, 20mA maximum
Input Over-range fault indication	20.000 mA minimum, 20.500 mA maximum (note 1)
Maximum Input	30 mA
Input Open Wire (4-20mA scaling only)	2.0mA typical (note 2)
Input impedance	249.75 to 250.25 Ohms
Conversion time @ 1MHz clock	60 Microseconds per channel, typical
Input filter Type Transition frequency	1st order RC 160 Hz typical
Maximum error at 25 degrees C (note 3)	+/- .05% full scale, 0.1 < Input < 20mA
Non-linearity	+/- .025% of full scale
Temperature coefficient	+/- .002% of value per degree C, typical, +/- .005% of value per degree C, maximum

note 1: BIU produces the over-range diagnostic if the input data is over full scale.

note 2: BIU produces the open wire diagnostic if input data is below minimum value for 4-20 scaling.

note 3: In the presence of severe RF interference (IEC 801-3, 10V/m), accuracy may be degraded to 5% of full scale.

Keying Locations

Optional keying locations for the Current Source Analog Input Module are:

Keying Locations									
A	B	C	D	E	F	G	H	J	K
x			x			x	x		

Field Wiring

The input signals share a single signal common return. For good noise immunity, establish system signal commons, power supply reference points, and grounds close to such single-ended points. Signal common (as defined by most Standards) for the input module is the negative side of the 24 volt supply. The module's chassis ground goes to the I/O Terminal Block ground terminal. To improve noise immunity, connect this to the enclosure chassis with a short length of wire.

Two wire loop powered transmitters (type 2) should have isolated or ungrounded sensor inputs. Loop powered devices should use the same power supply as the input module. If a different supply must be used, connect the signal common to the module common. Also, ground only one point on the signal common, preferably at the input module. If the power supply is not grounded, the entire analog network is at a floating potential (except for the cable shields). Thus this circuit can be isolated if it has a separate isolated supply.

If shielded wire is used to reduce noise pickup, the shield drain wires should have a separate path to ground from any loop power supply ground to avoid inducing noise due to drain current.

Three wire transmitters require a third wire to provide power. The shield may be used as the power supply return. If the system is isolated, a third wire (triad cable) should be used instead of the shield for the power, and the shields grounded.

A separate, remote power supply can also be used. A floating supply should be used for best results. Grounding both supplies creates a ground loop. The circuit may still work despite this, however achieving good results requires very good voltage compliance of the transmitter.

Isolated 4 wire transmitters can avoid ground loop problems with remotely powered sensors.

If the module is installed on an I/O Terminal Block with Barrier Terminals or an I/O Terminal Block with Wire to Board Connectors, additional wiring terminals are needed. For an I/O Terminal Block with Barrier Terminals, an Auxiliary Terminal Block can be used. For the I/O Terminal Block with Wire to Board Connectors, external connection points are usually preferred, although an Auxiliary Terminal Block can also be used.

Auxiliary Terminal Blocks have all terminals connected together internally. The Auxiliary Terminal Block with box terminals has 13 terminals, each of which accommodates one AWG #14 (avg 2.1mm² cross section) to AWG #22 (avg 0.36mm² cross section) wire, or two wires up to AWG #18 (avg. 0.86mm² cross section). The Auxiliary Terminal Block with barrier terminals has nine terminals, each of which can accommodate one or two wires up to AWG #14 (avg 2.1mm² cross section).

Current Source Analog Input Module

For 3-wire and 4-wire transmitters, an I/O Terminal Block with box terminals and Auxiliary I/O Terminal Block can be used without any additional terminal strip. An additional terminal strip is needed for an I/O Terminal Block with barrier terminals and an Auxiliary Terminal Block. The +24V Out terminals are a common fused output from DC+ to drive loop-powered 2 wire sensors. For anything other than 2-wire transmitters, jumper the Auxiliary Terminal Block to DC-.

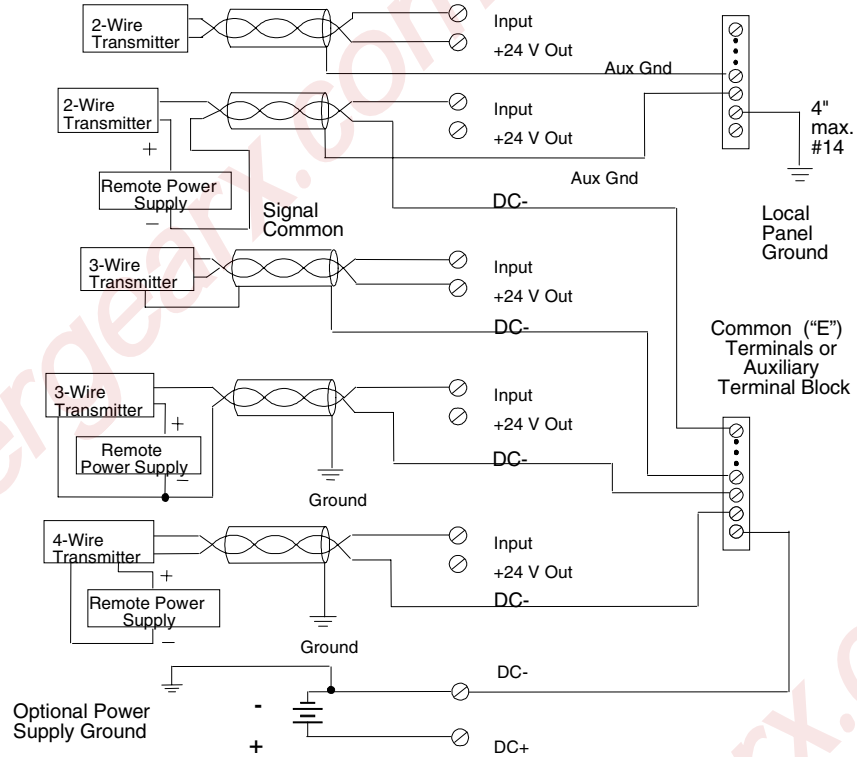

I/O Terminal Block wiring assignments for this module are shown below.

I/O Terminal Block with Box Terminals (IC670CHS002 and 102)	I/O Terminal Block with Barrier Terminals (IC670CHS001 and 101)	I/O Terminal Block with Wire to Board Connectors (IC670CHS003 and 103)
+24 V Out 16	+24V Out 16	Input 6 11
+24 V Out 14	+24V Out 14	+24V Out 12
Common E3	+24V Out 13	Input 5 13
+24 V Out 12	+24V Out 12	+24V Out 14
+24 V Out 10	+24V Out 11	Input 7 13
Common E6	+24V Out 10	+24V Out 14
+24 V Out 8	+24V Out 9	Input 4 15
+24 V Out 7	+24V Out 8	+24V Out 16
+24 V Out 6	+24V Out 7	Input 8 15
Common E4	+24V Out 6	+24V Out 5
+24 V Out 4	+24V Out 5	Input 3 A2
+24 V Out 2	+24V Out 4	DC+ A1
Common E2	+24V Out 3	DC- B2
DC- B2	+24V Out 2	DC- B1
DC- B1	DC- B	DC- B1
Input 8 15	Input 8 15	+24V Out 10
Input 7 13	Input 7 13	Input 5 9
Input 6 11	Input 6 11	+24V Out 8
Input 5 9	Input 5 9	Input 7 10
Input 4 7	Input 4 7	+24V Out 6
Input 3 5	Input 3 5	Input 8 6
Input 2 3	Input 2 3	+24V Out 4
Input 1 1	Input 1 1	+24V Out 5
Common E1	Common A	DC+ 4
DC+ A2	DC+ A	+24V Out 2
DC- A1	DC- A	+24V Out 3
DC+ A2	DC+ A	Input 1 1
DC+ A1	DC+ A	

Terminals E1, E2, E4, E6, and E8 are electrically connected together, A1 and A2 are electrically connected together, B1 and B2 are electrically connected together.

Chapter 19

16 Point Grouped Analog Input Module IC670ALG240

The 16 Point Grouped Analog Input Module (IC670ALG240) accommodates 16 current loop inputs on a common power supply. It accepts inputs from two-wire or three-wire current transmitters and converts input levels to digital values.

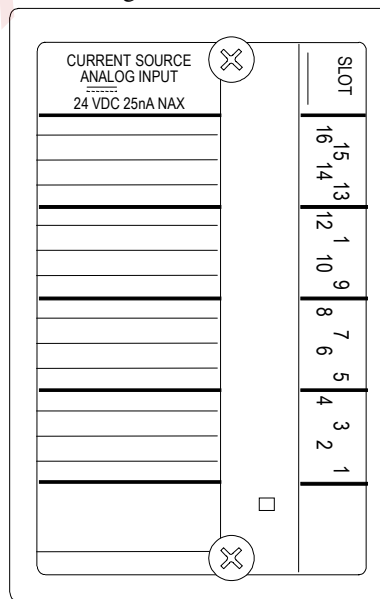

- Supports 16 channels of input currents ranging from 0 to 25 mA.
- Uses both word and bit data types.
- Can be field-recalibrated or reset to factory calibration. Calibration data stored in FLASH memory.
- Two data acquisition rates based on 50 Hz and 60 Hz line frequencies.
- Individual channel configuration.
- 10mS or 20mS digital filtering may be used to eliminate noise.
- Selectable scaling of input data.
- Configurable high and low alarm values.
- Reports High/Low, Under/Ovrange, and Open Wire alarms.

Power Sources

The module does not require a separate power supply to operate. However, power for the current loops must be provided externally. The most common application would have the loop supply local at the module, driving 2-wire loop-powered transmitters.

LED

A single indicator shows module status:

- ON: normal operation
- Intermittent flashing: Diagnostic code indication. The module does not send inputs.
- OFF: No backplane power, or fatal fault.

Module Operation

Following a successful powerup, the module begins scanning data.

Input current signals are applied to a 250-ohm input shunt resistor which changes this to a voltage with respect to a common. All inputs are referenced to the same return, as shown in the equivalent input circuit.

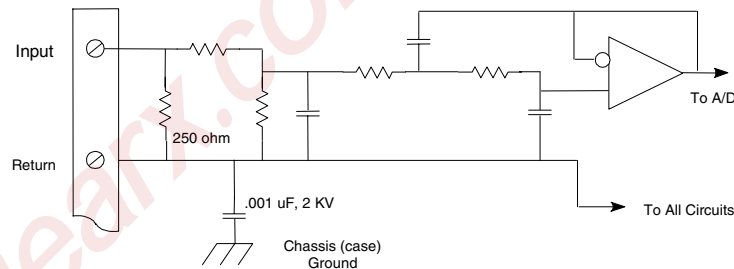

The module stores the most recent 16 samples for each channel in a buffer. The outputs of the buffer amplifiers are sequentially connected by an analog multiplexer to a 16-bit A/D converter. All channels are converted approximately once every millisecond. The input span of the A/D is fixed, presenting binary values of 0 to 65535 for 0 to 25 milliAmps, with one LSB = 0.38 microAmps.

Samples are filtered according to the configured software filter. After filtering is performed, the module adjusts data using scaling and offset constants. These are pre-calculated for each channel from the calibration data, selected range, and specified engineering units.

The module checks scaled data against configurable alarm limits and against predefined values for overrange, underrange, and broken wire conditions. If one of the following error conditions occurs on a channel, the module sets a corresponding diagnostic bit (flag) in its configured discrete input (%I) data, which can be monitored by the application logic. These faults are latched and can be reset by sending appropriate fault-clearing (%Q) data to the module.

- **High Alarm/Low Alarm:** These diagnostics indicate that a scaled analog value is greater than its high alarm or less than its low alarm limit. Each channel can have a High Alarm and Low Alarm limit.
- **Open Wire:** This diagnostic indicates that a channel which has a low span value for scaling that is greater than 2mA, and its actual input current is less than approximately 2mA.
- **Overrange/Underrange Alarm:** Indicates input value has reached A/D converter limits.

All analog user side connections are isolated from the Field Control backplane.

Host Interface

The 16 Point Grouped Analog Input module uses the following types of data:

- 16 analog inputs (16 words)
- 88 bits of discrete input data for module and channel status (use of this data is optional).
- 16 bits of discrete output data for fault-clearing commands to the module (also optional).

The module exchanges data with a Bus Interface Unit in the same manner as other types of I/O modules-it provides all its input data and status bits when requested by the BIU, and receives fault-clearing commands from the BIU via its assigned output bits.

Compatibility

This module must be used with a Bus Interface Unit revision 2.0 or later.

Module Configuration Overview

Like other Field Control modules, the 16 Point Analog Input module is usually configured from the Bus Interface Unit, using a compatible hand-held programmer. The module's configuration can also be read or written from the bus when used in a system that supports such configuration. The table below summarizes configuration choices and defaults. The module will power up with the default configuration settings. For configuration instructions, refer to the *Bus Interface Unit User's Manual*.

Module Parameter	Description	Default	Choices
Analog Input Data Length	Word length of the module's analog input data in the BIU's analog input (AI) data table.	16	0-16
Analog Input Data Reference	Starting offset for the module's analog input data in the BIU's analog input (AI) table.		user selected
Discrete Input Data Length	Bit length for the module's optional status data in the BIU's discrete input (I) table.	88	0-88
Discrete Input Data Reference	Starting offset for the module's status data in the BIU's discrete input (I) table.		user selected
Discrete Output Data Length	Bit length for the module's optional fault-clearing bits in the BIU's discrete output (Q) table.	16	0-16
Discrete Output Data Reference	Starting offset for the module's optional fault-clearing bits in the BIU's discrete output table.		user selected
Filtering Method	Determines how the module will perform input filtering.	20mS	10mS, 20mS
Line Frequency	Specifies the line frequency. The module uses this data to control the sampling rate.	60 Hz	50 Hz, 60 Hz
Channel Active	Specifies if the channel should return data and alarms. If a channel is "inactive" space is still allocated for it.	Active	Inactive (off) Active (on)
Range	Specifies the range for the input. (1) 4mA = 4000, 20mA = 20000 (2) 4mA = 0, 20mA = 32000 (3) 0mA = 0, 20mA = 32000 (4) 0mA = 0, 24mA = 32000	1	1, 2, 3, 4
Span Low	Actual current in microAmps to be scaled to low engineering units value	4000	0 to 25000
Span High	Actual current in microAmps to be scaled to the high engineering units value	20000	0 to 25000
Engineering Low	The engineering units value that is considered equivalent to the low span (actual) value.	4000	-32,768 to +32,757.
Engineering High	The engineering units value that is considered equivalent to the high span (actual) value.	20000	-32,768 to +32,767
Alarm Low	The low alarm limit for the channel, in engineering units.	4000	-32,768 to +32,767
Alarm High	The high alarm limit for the channel, in engineering units.	20000	-32,768 to +32,767

Module Features

Channel Active

Each channel can be configured as either active or inactive. If a channel is inactive, it is not scanned. The filtering, scaling, calibration, and alarm checks are omitted for that channel, and a value of 0 is returned to the BIU.

Filtering

The module uses an input filter, a line filter, and an averaging filter to reduce the effect of disturbances due to noise. Typical noise sources include high frequency signals superimposed on the input signal and AC variations. AC noise can be caused by power supply ripple in analog sources, line pickup, or other random pickup. The module's input filter is hardware-controlled while the line and averaging filters are software-configurable for any active channel. Filtering does not eliminate the need to control input signal quality by providing stable signal sources, stable power supplies, proper signal shielding, and appropriate signal separation.

Input Filter

The input signal passes through a low-pass input filter. This filter is a second-order active RC filter with a transition (corner) frequency of 10Hz.

Line Filter

Disturbances due to AC noise cause variations around the desired DC level. These variations appear at a beat, or "alias" frequency. The amplitude of these variations can be reduced by configuring the rate at which the module scans inputs for the operating frequency. Line frequency is configurable as 50 or 60 Hz. If the line frequency is configured at 60 Hz, the module scans each input channel every 1.04 milliseconds. If the line frequency is configured at 50 Hz, the module scans each input channel every 1.25 mS.

Averaging Filter

The software filter is an averaging filter that runs at the line frequency. This filter provides additional low-pass response, and high rejection at line frequency and select harmonics of the line frequency. The averaging filter configuration choices are:

1. **20 mS:** The average value of 16 A to D conversion samples taken over a full line cycle (16.67mS at 60 Hz, 20 mS at 50 Hz). This filter provides additional rejection at 60, 120 and 180 Hz for 60Hz operation. The 50 Hz response is similar, with the rejection notches at 50, 100, and 150 Hz.
2. **10 mS:** The average value of 8 samples over a half line cycle (8.3 mS at 60 Hz, 10 mS at 50 Hz). This option improves the signal-to-noise ratio due to the integrating effect of an 8-sample average. The 10 mS filter does not significantly improve AC line rejection because additional rejection is only offered at 120Hz for 60Hz operation and 100Hz for 50Hz operation.

Because frequency tolerance for the 20mS and 10mS filter options is relatively narrow, it is important to configure line frequency properly. Also, low frequency noise is not affected by this averaging filter as shown by the following example. If required, additional averaging or exponential filters may be set up in the CPU to further process the data.

Input Frequency Response

The graph shows the effects of configurable filtering on module response when the module is configured for operation at 60Hz. The response of both 10mS and 20mS filter options is shown. As explained, maximum line frequency rejection is obtained with the 20mS filter option.

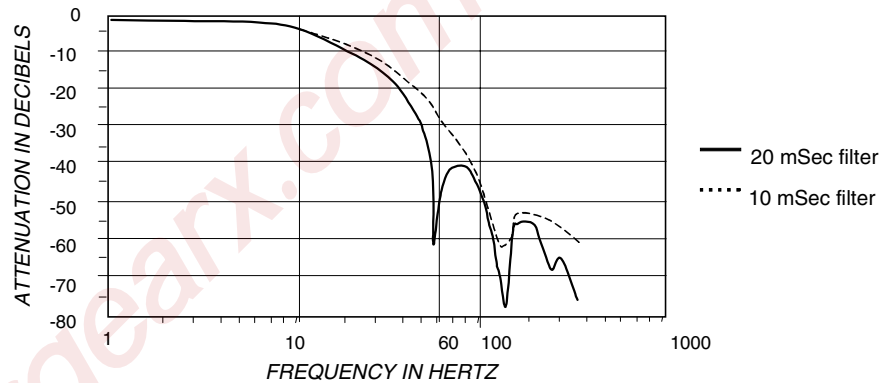

Line Frequency Rejection Calculations - Examples

The response curve above can be used to calculate maximum permissible AC line variations for a given data stability. For example, using the 20mS input filter, the best possible rejection of AC noise is -62dB or $20 \log(1/562)$ assuming a clean 60Hz signal. The actual rejection may be less if the frequency deviates. This ratio (1/562) is the relationship between data stability and the error signal. For a system with a full scale of 20,000 microAmps and an LSB resolution of 1 microAmp, stability resolving 1 part in 20000 requires the maximum AC line frequency component of the signal be less than 562 microAmps peak-to-peak.

It is also possible to calculate the best resolution for a given AC disturbance. For example, a full scale (20,000 microAmp) 60 Hz AC disturbance on the above system would produce a data variation of 35 microAmps ($20,000/562$) or 0.18% of full scale.

Low Alarm Limit and High Alarm Limit

Each input channel can have a low alarm limit and a high alarm limit. If an input reaches one of its limits, the module reports the actual value and sends the appropriate diagnostic bit in the %I table of the BIU. Alarms do not stop the process or change the value of the input.

Alarm limits can be set anywhere over the dynamic range of the signal. The range for each is -32,768 to +32,767. The high alarm limit must be greater than the low alarm limit. If alarm reporting is not wanted, alarm limits can be set beyond the dynamic range of the signal so they will never be activated.

Range Selection

There are four predetermined range and data scaling combinations, plus custom scaling.

Selection	Input Current (μ A) = Data Range (Engineering Units)	Open Wire
1	4000 to 20000 = 4000 to 20000 (default)	Enabled
2	4000 to 20000 = 0 to 32000	Enabled
3	0 to 20000 = 0 to 32000	Disabled
4	0 to 24000 = 0 to 32000	Disabled
none	Custom; scaling by user	Selectable

Selection 2 will actually convert the full input current span down to 0 milliAmps and produce negative values below 4 mA. Selection 1 produces engineering unit data in microAmps. The others are binary-weighted. "None" permits selectable scaling.

Input conversions over full scale at about 25mA input produce an Overrange diagnostic. Input conversions below a minimum 2mA value when selected range low span value is greater than 2mA produce an Open Wire diagnostic. Input conversions at approximately 0mA value when 0-25mA range is selected produce an Underrange diagnostic.

Scaling

Scaling defines a linear relationship between a channel's input current in microAmps (μ A) and the value in engineering units returned to the BIU. The default scaling configuration provides values from 4,000 to 20,000 for an input current range of 4mA (low span value) to 20mA (high span value). The illustration below shows scaling for the default range selections.

To scale a channel, choose a high and low point and enter the actual input value (span) and a corresponding engineering units value for each. During operation, the module will use these values to convert input currents into digital values that represent engineering units. The "Open Wire" diagnostic bit is enabled if actual input current value used for the "Low Point" is greater than 2 milliamps.

Engineering units values are 16-bit signed integers from -32767 to +32767. Span values are unsigned integers ranging from 0 to 25,000.

If the scaled data falls below the minimum for engineering units, the module returns the minimum engineering units value (-32768). If the scaled data rises above the maximum for engineering units, the module returns the maximum engineering units value (+32767).

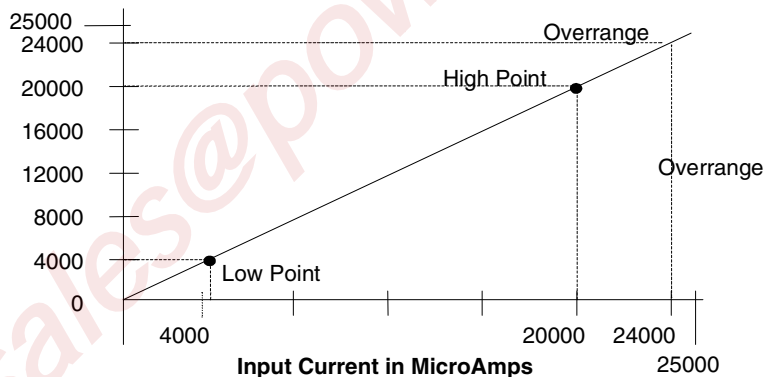

Module Specifications

Number of channels (single ended)	16
Converter resolution	16 bits (unscaled)
Converter LSB weight, referenced to input	381 NanoAmps, typical
Input current span for 16 bits	0 mA minimum, 25 mA maximum
Operating temperature range	0 to 55 degrees C ambient
Current Loop Power Supply	20-28V nominal, 10% ripple maximum
Current Drawn from BIU Power Supply	251 mA maximum
Maximum Input (without damage)	35mA, continuous, maximum
Non-linearity	1 microAmp or 1 LSB
Temperature coefficient	+/- .002% of value per degree C, typical, +/- .005% of value per degree C, maximum
Isolation to ground and logic	1500 VAC for 1 minute. 250 VAC continuous.
Input or channel to channel common mode voltage	None; single-ended input
Maximum error at 25 deg. C	+/- 0.05% of full-scale value or +/- 10 microAmps referred to input (see note)
Input hardware filter type	2nd order, active RC
Input filter transition frequency	10Hz
Software normal mode filter type	Averaging, comb response
Normal mode filter notch frequency	50 or 60 Hz, selectable. (Also rejects harmonics of selection)
Software filter time selection	10 millisecc, or 20 millisecc
Normal mode rejection (approximate)	at 50 Hz +/- 1 Hz at 60 Hz +/- 1 Hz
Filter "10 millisecc"	--25 dB --28 dB
Filter "20 millisecc"	--50 dB --50 dB
Common mode rejection (all channels to ground)	86 dB minimum voltage
Common mode rejection, channel to channel	None (single ended input with common return)
Input impedance	250 Ohms
Open wire (4-20mA scaling only)	2.0 mA, typical
Overrange	25 mA, typical
Underrange (0-25 scaling)	0 mA, minimum

note: Calibration as corrected by using factory calibration data stored in module. Based on 4-20mA span. Under severe electrical ambient conditions, such as 10 Volt/meter (IEC 801-3), accuracy may be temporarily degraded as follows: , filter "10mS" 0.5%, filter "20mS": 0.25%.

Keying Locations

Optional keying locations for the Current Source Analog Output Module are:

Keying Locations									
A	B	C	D	E	F	G	H	J	K
x			x			x	x		

Field Wiring

Instrumentation grade Shielded Twisted Pair wire should be used for best noise immunity. The shield should be terminated at a local panel ground near the module.

All inputs are referenced to a common return point for the negative side of the loop power supply, brought out to the B terminal. The A terminal is not used. Three wire or negative-referenced sources may require connection to terminal B. An additional external terminal strip may be needed for the returns.

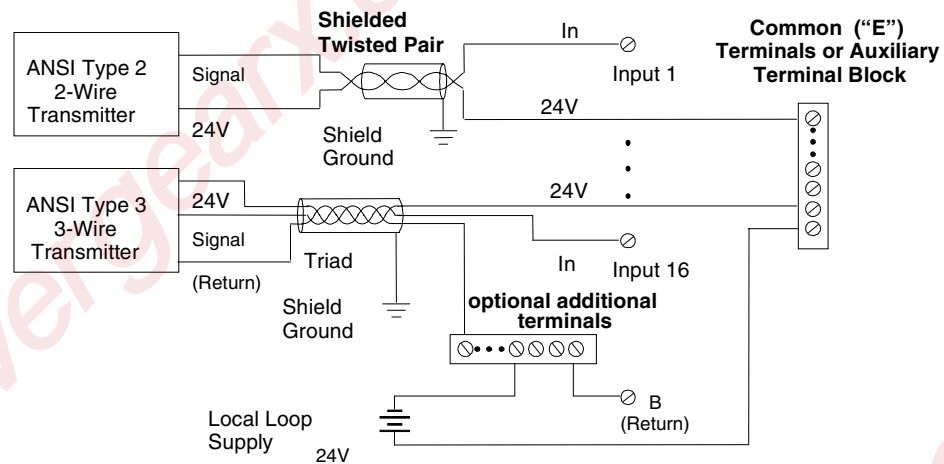

If the module is installed on an I/O Terminal Block with Barrier Terminals, an Auxiliary Terminal Block can be used as shown to provide the additional wiring terminals. For the I/O Terminal Block with Wire to Board Connectors, external connection points are usually preferred, although an Auxiliary Terminal Block can be used. Auxiliary Terminal Blocks have all terminals connected together internally.

The Auxiliary Terminal Block with box terminals has 13 terminals, each of which accommodates one AWG #14 (avg 2.1mm² cross section) to AWG #22 (avg 0.36mm² cross section) wire. The Auxiliary Terminal Block with barrier terminals has nine terminals, each of which can accommodate one or two wires up to AWG #14 (avg 2.1mm² cross section).

I/O Terminal Block Terminal Assignments

The diagrams below show terminal assignments for the different types of I/O Terminal Block that can be used with the module. The Terminal Block with Box Terminals has 25 terminals for each module. Each accommodates one AWG #14 (avg 2.1mm² cross section) to AWG #22 (avg 0.36mm² cross section) wire, or two wires up to AWG #18 (avg. 0.86mm² cross section). When an external jumper is used, single-wire capacity is reduced from AWG #14 (2.10mm²) to AWG #16 (1.32mm²).

The I/O Terminal Block with Barrier Terminals has 18 terminals per module. Each terminal can accommodate one or two wires up to AWG #14 (avg 2.1mm² cross section).

The I/O Terminal Block with Connectors has one 20-pin male connector per module.

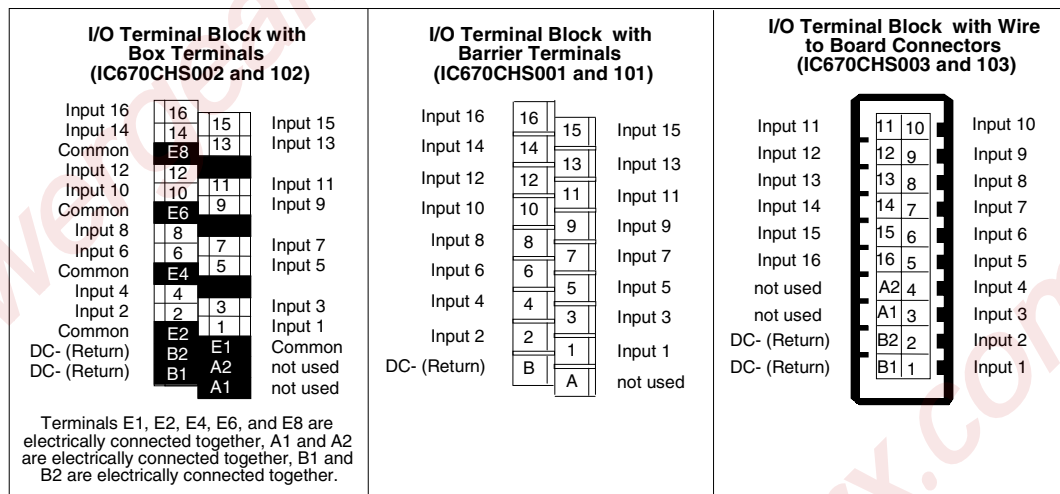

Diagnostics Data

The 16 Point Grouped Input module performs diagnostics and provides 88 bits (11 bytes) of diagnostic data to the BIU. The module sets the appropriate bit when a diagnostic condition is detected. The bit remains set until cleared by the appropriate discrete output bit, as described on the next page. Use of this data is optional. The module is easily configured to use of all, some, or none of it.

Module Diagnostics Bits (byte 0)

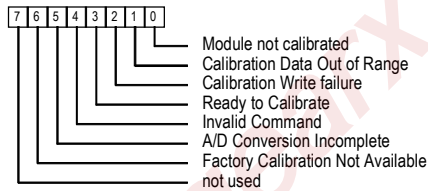

Channel Alarm Bits (bytes 1-4)

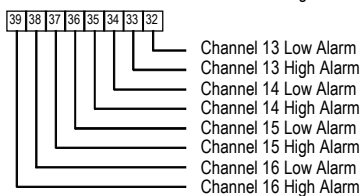
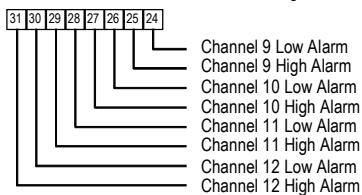
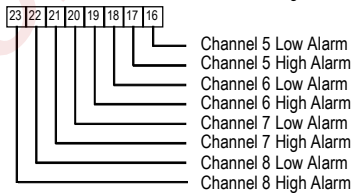
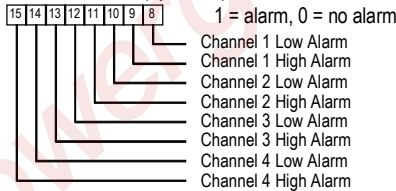

Channel Under/Overrange Bits (bytes 5-8)

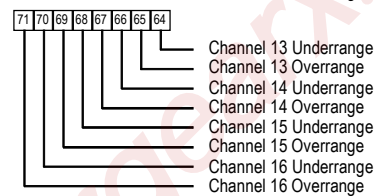
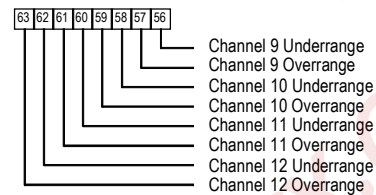
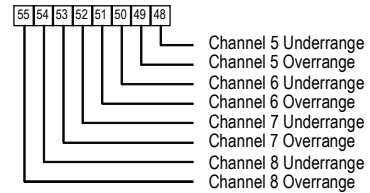
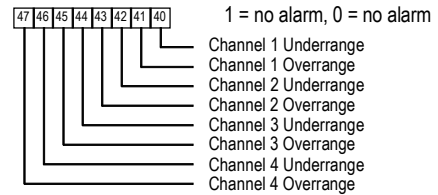

Channel Open Wire Bits (bytes 7, 8)

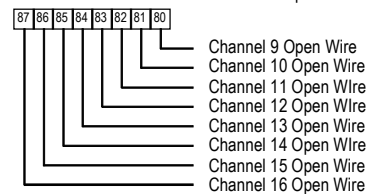
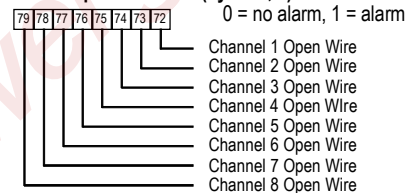

Clearing Faults and Alarms

Two bytes of discrete output data can be used to clear module faults and alarms. These alarm bits start at the module's configured discrete output reference.

Setting the output bit for a channel to 1 clears all the fault bits for that channel that are currently set.

Output Command Bits to Clear Diagnostics

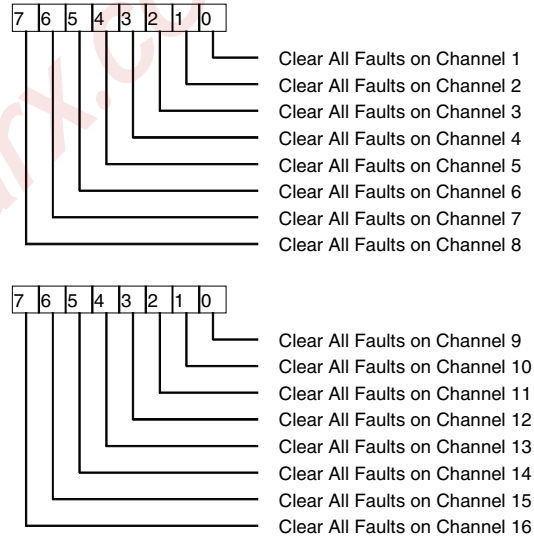

Chapter 20

RTD Analog Input Module IC670ALG620

The RTD Analog Input Module (IC670ALG620) accepts inputs from 4 independent 3-wire and/or 4-wire platinum, nickel, nickel/iron, or copper RTDs.

Module features include:

- Selectable resistance measurements in tenths of ohms, tenths of degrees Fahrenheit, or tenths of degrees Celsius
- Individual channel configuration
- Selectable resistance ranges: 0 - 500 ohms and 0 - 3000 ohms
- Selectable RTD input as resistance or temperature (Celsius or Fahrenheit)
- Reports high/low, underrange/overrange, open wire and input short alarms.
- Uses optional discrete inputs and outputs for status and control.
- Two data acquisition rates based on 50 Hz and 60 Hz line frequencies
- Configurable channel activation

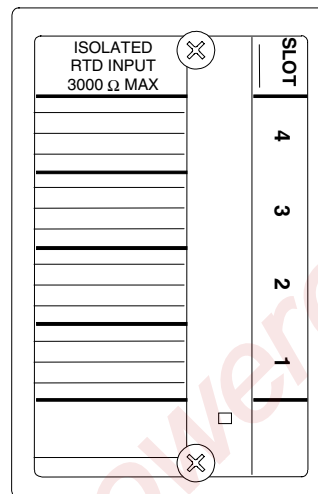

Power Sources

No loop power is required for this module. The excitation current for the RTDs is provided by the module, which automatically matches the excitation current to each configured RTD type.

LED

A single indicator shows module status:

- ON: normal operation
- Intermittent flashing: module fault
- OFF: loss of backplane power or fatal fault

Module Operation

The RTD Input Module accepts four inputs from three-wire or four-wire RTDs and converts the input level to a digital value. Input spans support a variety of RTD types, as listed in the Module Specifications section.

The analog/digital converter reads the voltage generated by each of the four inputs. The A/D converter converts the differential measurement into a binary value (15 bits plus sign), which is read by the block's microprocessor. The microprocessor sets the gain required in the analog/digital converter for each individual input. The gain is based on the RTD type that has been configured for that input.

The microprocessor selects the input by means of a solid state, optically-coupled multiplexer. Three measurements are made for each input: Excitation current, RTD resistance including field wire drop, and field wire drop. From these three measurements, the module calculates the RTD resistance. A DC/DC converter circuit isolates the field side from the logic circuits.

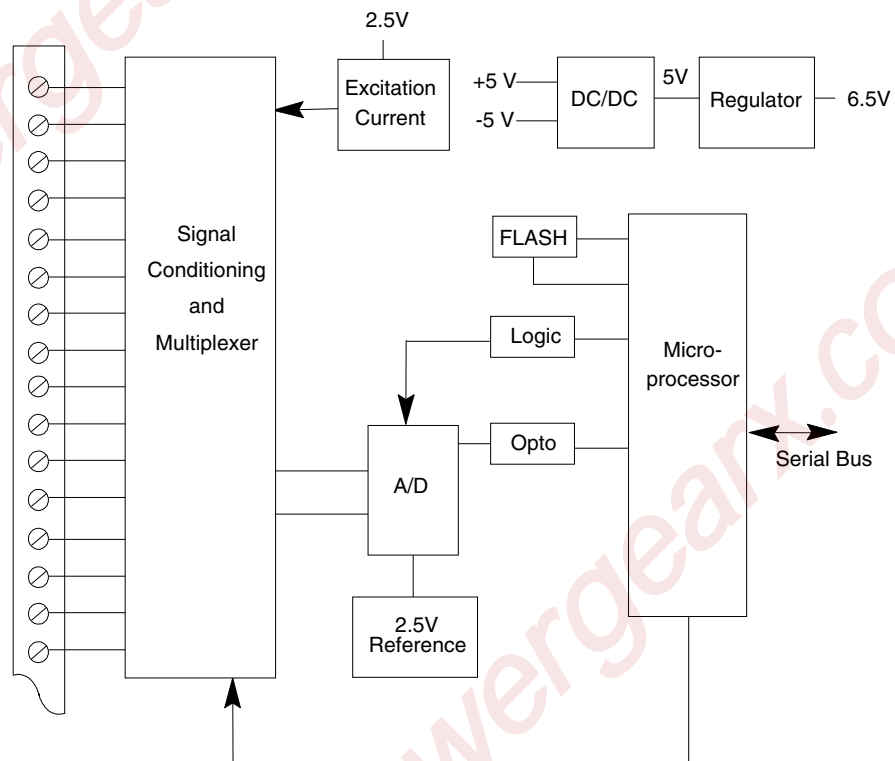

46723

Calibration

The module automatically performs A/D calibration at powerup. Automatic calibration is then repeated every minute to compensate for changes in the ambient temperature. The module stores the calibration constants for each gain in RAM memory.

Host Interface

The RTD Input module has the following data types:

- 4 analog inputs (4 words)
- 32 bits of discrete input data for module and channel status (use of this data is optional)
- 8 bits of discrete output data for fault clearing to the module (also optional)
- Analog output data defaults to a length of 0, and should NOT be used for most applications.

A starting reference and length in the Bus Interface Unit (BIU) data tables for each data type is selected during module configuration. Depending on the configuration that has been set up for each RTD, the input data can be reported as tenths of ohms, tenths of degrees Fahrenheit, or tenths of degrees Celsius.

This module exchanges data with a BIU in the same manner as other types of I/O modules-it provides all its input data and status bits when requested by the BIU, and receives fault-clearing commands from the BIU via its assigned output bits. Note that the BIU can be configured not to send status data over the network.

The module can also be configured for "Group" data transfer with the BIU or with other intelligent devices in the same Field Control station. Group data transfer, and the steps for configuring it, are described in the *Bus Interface Unit User's Manual*.

Units Selected	Integer Ranges	Engineering Units Ranges
Tenths of Degrees	-32767 to +32767	-3276.7deg. to +3276.7 deg.
Tenths of Ohms	0 to 65535	0 Ohms to 6553.5 Ohms

Compatibility

This module must be used with a Bus Interface Unit revision 2.0 or later.

Module Configuration Overview

Like other Field Control modules, the RTD Input module is usually configured from the Bus Interface Unit, using a compatible hand-held programmer. The module will also accept configuration data from the bus when used in a system that supports such configuration. The table below summarizes configuration choices and defaults. The module will power up with the default configuration settings. For configuration instructions, refer to the *Bus Interface Unit User's Manual*.

Module Parameter	Description	Default	Choices
Analog Input Data Length	Word length of the module's analog input data in the BIU's analog input (AI) data table.	4	0-4
Analog Input Data Reference	Starting offset for the module's analog input data in the BIU's analog input (AI) table.		user selectable
Discrete Input Data Length	Bit length for the module's optional status data in the BIU's discrete input (I) table.	32	0-32
Discrete Input Data Reference	Starting offset for the module's status data in the BIU's discrete input (I) table.		user selectable
Discrete Output Data Length	Bit length for the module's optional fault-clearing bits in the BIU's discrete output (Q) table.	8	0-8
Discrete Output Data Reference	Starting offset for the module's optional fault-clearing bits in the BIU's discrete output table.		user selectable
Analog Output Data Length	Word length for analog output data in the BIU's analog output (AQ) table. Should not be used for most applications.	0	0-4
Analog Output Data Reference	Starting offset for the module's analog output data in the BIU's AQ table.		user selectable
Line Frequency	Specifies the line frequency.	60 Hz	50 Hz, 60 Hz
Channel Active	Specifies if the channel should return data and alarms. If a channel is "inactive" space is still allocated for it.	Active	Inactive (off), Active (on)
Units	The conversion type for each RTD.	Deg C	tenths of ohms, tenths of degrees C, or tenths of degrees F
RTD Type	The type of RTD used for each channel.	100 PT 385	10 PT, 25 PT, 25.5 PT 392, 100 PT 385, 100 PT 3902, 100 PT 392, 100 PT 3923, 100 PT 3916, 1K PT 375, 10 CU, 10 CU 427, 50 CU 427, 100 CU 427, 100 NI, 100 NI 618, 120 NI 672 604 NI/FE 518, 1K NI/FE 527, 500 Ohm, 3000 Ohm
Wire Type	The type of field wiring for each RTD.	3 Wire	3 Wire, 4 Wire
Alarm Low	The low alarm limit for the channel, in engineering units.	-200	-32,768 to +32,767
Alarm High	The high alarm limit for the channel, in engineering units.	800	-32,768 to +32,767
Resistance	An optional resistance adjustment, in tenths of ohms. This adjustment scales the measured resistance before it is converted to degrees. The scaling is: (RTD-type-ohms/resistance* measured ohms) When the resistance adjustment is set to 0, it is not used.	0	0 to 3276.7

Module Features

Channel Active

Each channel can be configured as either active or inactive.

If a channel is inactive, it is not scanned and a value of 0 is returned to the BIU.

If a channel is active, and the configured analog input data length is not long enough to accommodate the data for a particular channel, the data for that channel is still processed, since the response to a group command may be used to transmit that channel's data to the BIU.

Low Alarm Limit and High Alarm Limit

Each input channel can have a low alarm limit and a high alarm limit. If an input reaches one of its limits, the module reports the actual value and sends the appropriate diagnostic bit in the discrete input table of the BIU. Alarms do not stop the process or change the value of the input.

Alarm limits can be set anywhere over the dynamic range of the signal. The range for each is -32,768 to +32,767. The high alarm limit must be greater than the low alarm limit. If alarm reporting is not wanted, alarm limits can be set beyond the dynamic range of the signal so they will never be activated.

Input Selection to Include RTD Type

Each input channel can have a different RTD type, selectable from a list of many different RTDs.

If the actual RTD resistance does not match the defined type, an adjustment factor can be configured in tenths of ohms.

Selection	Comments	Selection	Comments	Selection	Comments
10 PT	10 Ohm Platinum (PT)	100 PT 3916	100 Ohm Platinum, $\alpha=.003916$	100 NI 618	100 Ohm Nickel At 0 deg.C, DIN43760, $\alpha=.00618$
25 PT	25 Ohm Platinum IPTS-68	1K PT 375	1 KOhm Platinum, $\alpha=.00375$	120 NI 672	120 Ohm Nickel, at 0 deg.C, $\alpha=.00672$
25.5 PT 392	25.5 Ohm Platinum, $\alpha=.00392$ at 0 deg.C Lab Std	10 CU	10 Ohm Copper, at 25deg. C, IPTS-68	604 NI/FE 518	604 Ohm Nickel/Iron, at 0deg. C, $\alpha=.00518$
100 PT 385	100 Ohm Platinum, DIN43760, $\alpha=.00385$	9.035 CU 427	9.035 Ohm Copper, at 25 deg.C, $\alpha=.00427$	1K NI/FE 527	1 KOhm Nickel/Iron, at 70 deg.F, $\alpha=.00527$
100 PT 3902	100 Ohm Platinum, $\alpha=.003902$	50 CU 427	50 Ohm Copper, $\alpha=.00427$	500 OHM	Select UNITS of 1/10 Ohms
100 PT 392	100 Ohm Platinum, $\alpha=.00392$ IPTS-6 8	100 CU 427	100 Ohm Copper, $\alpha=.00427$	3000 OHM	Select UNITS of 1/10 Ohms
100 PT 3923	98.13 Ohm Platinum, $\alpha=.003923$	100 NI	100 Ohm Nickel, IPTS-68		

RTD Limits

The table below lists the ohms and temperature limits for different RTD types.

RTD Type	Low α Limit	High α Limit	Low Temp. deg.C	High Temp. deg. C
10 Ohm Copper @ 25deg. C	6.13600	14.8200	-75.00	150.00
10 Ohm Platinum @ 25deg. C	7.02000	37.2599	-70.00	1000.00
25 Ohm Platinum	4.14500	74.3089	-201.1111	537.77
100 Ohm Nickel	80.88890	147.7700	-40.00	140.00
1 KOhm Platinum, $\alpha=.00375$	199.4880	2754.620	-200.00	500.00
100 Ohm Platinum $\alpha=.00385$	27.01	389.936	-180.0	850.0
100 Ohm Platinum, $\alpha=.003902$	93.5400	135.000	-17.7777	99.9999
100 Ohm Platinum IPTS68 (PA)	26.5	327.744	-200.0	630.0
100 Ohm Platinum SAMA-RC21-4 (PC)	26.5	311.874	-200.0	600.0
100 Ohm Platinum JISC-1604-'81	26.5	323.780	-200.0	620.0
25.5 Ohm Platinum Lab Std (PJ)	4.50	83.575	-200.0	630.0
9.035 Ohm Copper (CA)	6.05	16.400	-100.0	260.0
50 Ohm Copper (CB/2)	28.379	105.787	-100.0	260.0
100 Ohm Copper (CB)	56.757	211.574	-100.0	260.0
100 Ohm Nickel (NB)	69.520	223.221	-60.0	180.0
120 Ohm Nickel (NA)	66.600	380.310	-80.0	260.0
604 Ohm Nickel/Iron (FA)	372.789	1318.722	-100.0	204.0
1 KOhm Nickel/Iron (FB)	566.576	1985.891	-100.0	204.0

Module Specifications

Module Characteristics	
Number of Channels	Four 3-wire and/or 4-wire RTDs
Scan time	60 Hz: approximately 210 milliseconds per point 50 Hz: approximately 230 milliseconds per point,
Fault detection	Open RTD, input short, underrange, overrange, and high/low alarm
Normal mode rejection	60dB, at 50/60 Hz, 100% span
Common mode rejection	120 dB at 50/60Hz, 100 ohm imbalance
Common mode voltage	250 Vrms (350 VDC or peak AC)
Normal mode voltage	100% overrange DC or peak AC operational 28 VDC or peak AC maximum
Isolation: User input to logic, user input to frame ground. Channel to Channel	1500 VAC for 1 minute, 250 VAC continuous. 250 VAC continuous.
Current drawn from BIU power supply	190 mA maximum
Digital Resolution	15 bits plus sign
Operating temperature range	0 to 55 Degrees C ambient
Channel Characteristics	
RTD types	10, 25, 100, and 1000 ohm platinum 10 and 100 ohm copper 100, 50, and 120 ohm nickel 604 ohms and 1000 ohms nickel/iron
Resistance ranges	0 to 500 ohms 0 to 3000 ohms
Accuracy, at 25deg. C	RTD: +/-0.15% of reading, +/-0.3 to 0.5 degree Celsius, depending on type
Temperature sensitivity (0deg. to 60deg. C)	+/-0.004% of reading, +/-1.5µV per deg. C referred to input
Maximum lead resistance	5 ohms per lead

Keying Locations

Optional keying locations for the RTD Module are:

Keying Locations									
A	B	C	D	E	F	G	H	J	K
x			x				x	x	

Field Wiring

The following illustration shows connections for 3-wire and 4-wire RTDs.

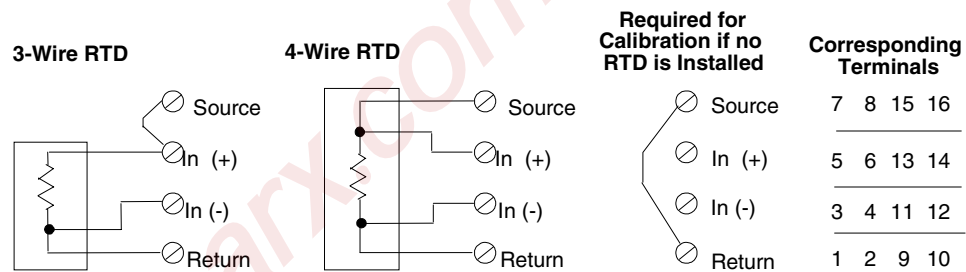

No loop power is required for this module. The excitation current for the RTDs is provided by the module, which automatically matches the excitation current to each configured RTD type.

I/O Terminal Block Terminal Assignments

The Terminal Block with box terminals (IC670CHS002) has 25 terminals for each module. Each accommodates one AWG #14 (avg 2.1mm² cross section) to AWG #22 (avg 0.36mm² cross section) wire, or two wires up to AWG #18 (avg. 0.86mm² cross section). When an external jumper is used, wire capacity is reduced from AWG #14 (2.10mm²) to AWG #16 (1.32mm²).

The I/O Terminal Block with barrier terminals (IC670CHS001) has 18 terminals per module. Each terminal can accommodate one or two wires up to AWG #14 (avg 2.1mm² cross section).

The I/O Terminal Block with Connectors (IC670CHS003) has one 20-pin male connector per module.

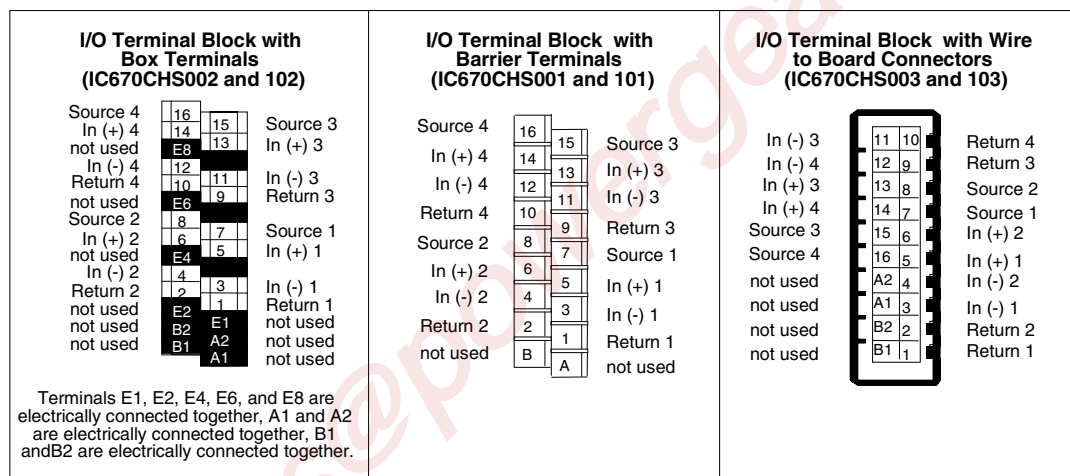

Diagnostics

The RTD module performs diagnostics and provides the diagnostic data to the BIU using its configured discrete input (I) references, starting at the configured reference offset.

The RTD sets the appropriate bit when a diagnostic condition is detected. The bit remains set until cleared.

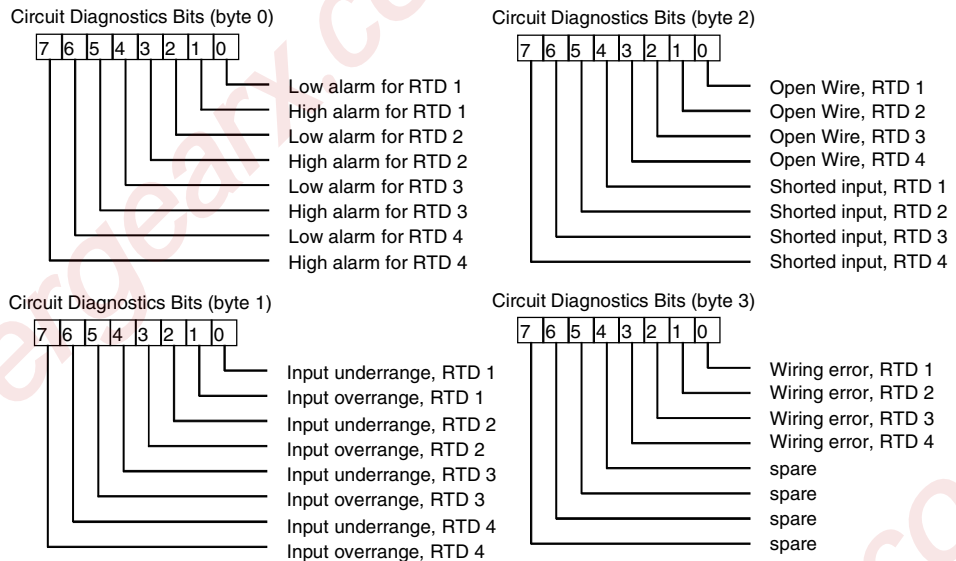

Clearing Faults and Alarms

Four optional discrete output bits in the BIU's discrete output (Q) table can be used to clear module faults and alarms.

Setting the discrete output bit for an RTD clears all diagnostic bits for that RTD that may be set.

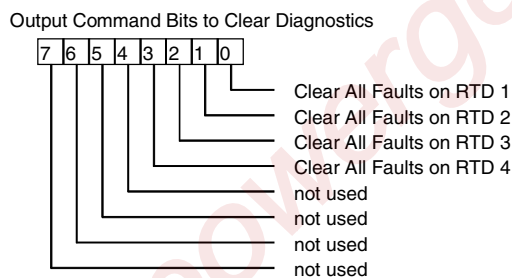

Chapter 21

Thermocouple Analog Input Module IC670ALG630

The Thermocouple Analog Input Module (IC670ALG630) accepts 8 independent thermocouple or millivolt inputs.

Module features include:

- Self-calibration
- Two data acquisition rates based on 50 Hz and 60 Hz line frequencies
- Individual channel configuration
- Configurable high alarm and low alarm levels
- Reports open thermocouple and out of range alarms

Each input channel can be configured to report:

- millivolts ranges as 1/100 of millivolts,

OR: thermocouples as linearized temperature in tenths of degrees Celsius or Fahrenheit, with or without cold junction compensation.

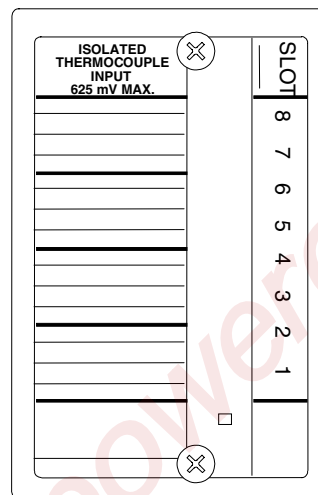

Power Sources

This module does not require a separate power supply to operate.

LED

- A single indicator shows module status:
- ON: normal operation
- Intermittent flashing: module fault
- OFF: no backplane power

Module Operation

The Thermocouple Input Module accepts eight inputs from thermocouples and converts the input level of each to a digital value. The module support a variety of thermocouple types, as listed in the Module Specifications section.

Each input can be configured to report data as millivolt or temperature (tenths of degrees Celsius or Fahrenheit) measurements.

When thermocouples are measured, the module can be configured to monitor the thermocouple junction temperature and correct the input value for cold junction.

On command from the module's internal microprocessor, the solid-state, optically-coupled multiplexer circuitry provides the present analog value of a specified input to the analog-to-digital converter. The converter turns the analog voltage into a binary (15 bits plus a sign bit) value representing tenths (1/10) of degrees Celsius or Fahrenheit. The result is read by the module's microprocessor. The microprocessor determines if the input is over or under its configured range, or if an open thermocouple condition exists.

When the module is configured to measure millivolts instead of inputs from thermocouples, the result of the analog-to-digital conversion is a value reported in hundredths (1/100) of millivolts.

A Bus Interface Module handles the exchange of all I/O data for the modules in the I/O Station over the communications bus.

The illustration below represents the main functional operations of the Thermocouple module.

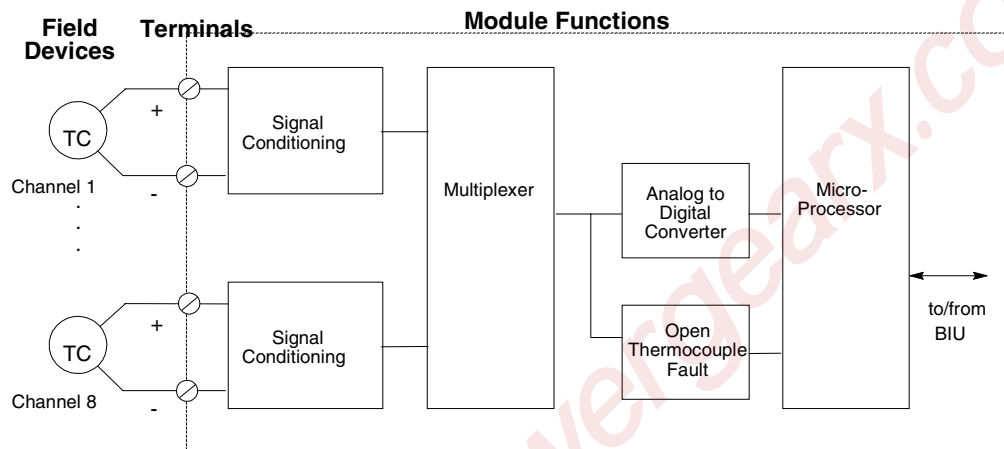

Calibration

The module automatically performs A/D calibration at powerup. Automatic calibration is then repeated every minute to compensate for changes in the ambient temperature. New calibration values are filtered into the current calibration values.

Host Interface

The Thermocouple Input module uses the following data types:

- 8 words of analog input data.
- 8 words of analog output data. This data is written to the module by the Bus Interface Unit (BIU). It contains the Reference Junction Compensation value, which is a 16-bit temperature value in degrees C. Use of this data is optional; it is needed only when Remote Compensation is configured for one or more channels on the module.
- 48 bits of discrete inputs for module and channel status data (use of this data is optional).
- 16 bits of discrete outputs for fault-clearing commands to the module (also optional).

The module exchanges data with a Bus Interface Unit in the same manner as other types of I/O modules—it provides all its input data and status bits when requested by the BIU, and receives fault-clearing commands from the BIU via its assigned output bits. Note that the BIU can be configured not to send status data over the network.

The module can also be configured for “Group” data transfer with the BIU or with other intelligent devices in the same Field Control station. Group data transfer, and the steps for configuring it, are described in the *Bus Interface Unit User's Manual*.

Compatibility

This module must be used with a Bus Interface Unit revision 2.0 or later.

Thermocouple Limits

The table below lists millivolt and temperature limits for applicable thermocouple types.

TC Type	Low mV Limit	High mV Limit	Low Temperature Limit ((C)	High Temperature Limit (C)
J	-8.0960	57.9420	-210.00	1000.00
K	-5.8910	54.8069	-200.00	1370.00
T	-5.6030	20.2520	-200.00	390.00
E	-8.8240	76.3580	-200.00	1000.00
S	-0.1940	18.5040	-40.00	1750.00
R	-0.1880	20.8780	-40.00	1750.00
B	0.03300	13.8140	100.00	1820.00
N	-0.57480	47.5019	-22.222	1300.00
G	-0.00600	38.5639	4.444	2315.55
C	0.23400	37.0660	-17.7777	2315.55
D	-0.16300	39.5060	-17.7777	2315.55
Platinel II	0.0000	52.25	0.00	1300.00

Module Configuration Overview

Like other Field Control modules, the Thermocouple Input module is usually configured from the Bus Interface Unit, using a compatible hand-held programmer. The module will also accept configuration data from the bus when used in a system that supports such configuration. The table below summarizes configuration choices and defaults.

The module will power up with the default configuration settings. These defaults may be changed as appropriate for the application. For configuration instructions, refer to the *Bus Interface Unit User's Manual*.

Module Parameter	Description	Default	Choices
Analog Input Data Length	Word length of the module's analog input data in the BIU's analog input (AI) table.	8	1 to 8
Analog Input Data Reference	Starting offset for the module's analog input data in the BIU's analog input (AI) table.		user selectable
Analog Output Data Length	Word length of the module's optional Reference Compensation data in the BIU's analog output (AQ) table.	8	0 or 8
Analog Output Data Reference	Starting offset for the module's optional Reference Compensation data in the BIU's analog output (AQ) table.		user selectable
Discrete Input Data Length	Bit length of the module's optional status data in the BIU's discrete input (I) data table.	48	0 or 48
Discrete Input Data Reference	Starting offset for the module's optional status data in the BIU's discrete input (I) data table.		user selectable
Discrete Output Data Length	Bit length of the module's optional fault-clearing commands in the BIU's discrete output (Q) table.	16	0 or 16
Discrete Output Data Reference	Starting offset for the module's optional fault-clearing commands in the BIU's discrete output (Q) table.		user selectable
Line Frequency	Specifies the line frequency. The module uses this data to control the sampling rate.	60 Hz	50 Hz, 60 Hz
Suppress Open Thermocouple	Determines whether or not the module will suppress Open Thermocouple diagnostics on the input data.	No	Yes, No
Channel Active	Specifies if the channel should return data and alarms. If a channel is "inactive" space is still allocated for it.	Active	Inactive (off) Active (on)
Engineering Units	Specifies how the module will report input values	Millivolts	Millivolts, 1/10 degrees-C, 1/10 degrees F
Thermocouple Type	The type of thermocouple present on each channel.	None	None, J, K, T, E, S, R, B, N, G, C, D, Platinel II
Range	For millivolt inputs only, the range for each channel in millivolts.	625	19.53, 39.06, 78.125, 156.25, 312.5, 625.
R J Type	Specifies how or whether the channel will perform Cold Junction compensation.	Local	Local, Remote, Fixed, None
Alarm Low	The low alarm limit for the channel, in engineering units.	-200	-32,768 to +32,767
Alarm High	The high alarm limit for the channel, in engineering units.	800	-32,768 to +32,767
Reference Junction Value	Specifies a reference value if Fixed RJ Type has been configured.	0	
Offset	Specifies optional amount to be added to compensated and linearized input value when a Conversion Type in degrees has been configured.	0	

Module Features

Channel Active

Each channel can be configured as either active or inactive. If a channel is inactive, it is still sampled from the A/D. The filtering, scaling, calibration, and alarm checks are omitted for that channel, and a value of 0 is returned to the BIU. The reference parameter for the analog input data returns the byte length and is independent of the number of active channels.

If a channel is active, and the configured analog input data length is not long enough to accommodate the data for a particular channel, the data for that channel is still processed, since the response to a group command may be used to transmit that channel's data to the BIU.

Low Alarm Limit and High Alarm Limit

Each input channel can have a low alarm limit and a high alarm limit. If an input reaches one of its limits, the module reports the actual value and sends the appropriate diagnostic bit in the BIU's discrete input (I) table. Alarms do not stop the process or change the value of the input. Alarm limits can be set anywhere over the dynamic range of the signal. The range for each is -32,768 to +32,767. The high alarm limit must be greater than the low alarm limit. If alarm reporting is not wanted, alarm limits can be set beyond the dynamic range of the signal so they will never be activated.

Cold Junction Compensation

The Thermocouple module provides four methods of Cold Junction Compensation.

- No Cold Junction Compensation: This is used for millivolt inputs or if cold junction is maintained at 0 degrees C.
- Remote Cold Junction Compensation: With this option, cold junction is measured externally and provided to the module by the BIU, using its %AQ output references. Regardless of which channel or channels use remote compensation, the compensation value must appear in the first analog output entry. This one value is used for all remotely-compensated thermocouples attached to the module. The value is in hundredths of a degree.
- Fixed Cold Junction Compensation: This option uses a fixed compensation value which is provided as part of the module configuration.
- Local Cold Junction Compensation: The best way to provide local compensation is with a Thermocouple Terminal Block. (IC670CHS004), which has two built-in thermistors. It shields thermocouple connections from module heat.

If local compensation is selected and a Thermocouple Terminal Block is not used, separate thermistors must be installed directly at the I/O Terminal Block, using the Thermistor (+) and Thermistor (-) terminals. The thermistor must be BetaTHERM part # 8.5K3A4 (or equivalent) from BetaTHERM Corp., 910 Turnpike Rd., Shrewsbury MA, 01545 (ph: 508 842-0516, FAX: 508 842-0748) **Note:** If local compensation is selected but a Thermocouple Terminal Block or local thermistors are not used, erroneous temperatures may be reported.

Range Selection

The module can be configured for any of six different millivolt ranges (+/-): 19.5mV, 39mV, 78.125mV, 156.25mV, 312.5mV, and 625mV. All but the last provide input readings in hundredths of millivolts. For the 625mV range, inputs are in tenths of millivolts.

Module Specifications

Module Characteristics	
Number of Channels	8 Each channel is individually configurable.
Thermocouple types	J, K, T, E, S R, B, N, G, C, D, Platinel II
Spans (+/-)	19.5mV, 39mV, 78.125mV, 156.25mV, 312.5mV, 625mV
Converter resolution	15 bits + sign
Cold junction compensation	If used, reference junction temperature either measured at thermocouple termination using a precision thermistor, or supplied by system, or by fixed configuration value.
Cold junction temperature error	+/-0.25 degree Celsius (local measurement). To reduce temperature transients, thermocouple terminations should not be installed in the same cabinet as high heat-dissipation assemblies.
Conformity error	+/-0.3 degree Celsius, +/-0.5 degree Fahrenheit.
Operating temperature range	0 to 55 degrees Celsius ambient.
Accuracy, at 25 deg. C on voltage measurement	+/-0.1% of reading, +/-0.05% of span for J, K, T, and E thermocouple types
Temperature sensitivity (0deg. to 60 deg.C)	+/-0.004% of reading, +/-1.5µV per deg. Celsius referred to input
Normal mode rejection	60dB, at 50/60 Hz, 100% span
Common mode rejection	120 dB at 50/60Hz, 100 ohm imbalance
Common mode voltage	250 Vrms (350 VDC or peak AC)
Maximum voltage between channels	250 VAC
Isolation: User input to logic, user input to frame ground. Channel to Channel	1500 VAC for 1 minute, 250 VAC continuous. 250 VAC continuous.
Current drawn from BIU power supply	195 mA maximum
Normal mode voltage	100% overrange DC or peak AC operational 28 VDC or peak AC maximum
Scan time	60 Hz: approximately 60 milliseconds per point 50 Hz: approximately 70 milliseconds per point.
Fault detection	Open Thermocouple, over/under range, and high/low alarm

Keying Locations

Optional keying locations for the Thermocouple module are:

Keying Locations									
A	B	C	D	E	F	G	H	J	K
x			x				x	x	

Installation Instructions

Thermocouples can be wired directly to the I/O Terminal Block on which the Thermocouple module is installed, or wired to an optional Thermocouple Terminal Block (IC670CHS004).

If a Thermocouple Terminal Block is used, installing the Thermocouple Module itself on an I/O Terminal Block with Wire to Board Connectors provides the simplest connection between terminal blocks. However, the module can be installed on any Field Control I/O Terminal Block. Terminal assignments for each type of Field Control I/O Terminal Block are shown below. Note that if a thermistor is connected locally to the I/O Terminal Block on which the module is installed, to achieve "local" cold junction compensation, the thermistor must be electronically identical to the thermistor in the Thermocouple Terminal Block.

The Terminal Block with box terminals has 25 terminals for each module. Each terminal accommodates one AWG #14 (avg 2.1mm² cross section) to AWG #22 (avg 0.36mm² cross section) wire, or two wires up to AWG #18 (avg. 0.86mm² cross section). When an external jumper is used, wire capacity is reduced from AWG #14 (2.10mm²) to AWG #16 (1.32mm²).

The I/O Terminal Block with barrier terminals has 18 terminals per module. Each terminal can accommodate one or two wires up to AWG #14 (avg 2.1mm² cross section).

The I/O Terminal Block with Connectors has one 20-pin male connector per module.

I/O Terminal Block with Box Terminals (IC670CHS002 and 102)	I/O Terminal Block with Barrier Terminals (IC670CHS001 and 101)	I/O Terminal Block with Wire to Board Connectors (IC670CHS003 and 103)																																																																																																																																				
<table border="0"> <tr><td>Input 8 (+)</td><td>16</td><td>15</td><td>Input 7 (+)</td></tr> <tr><td>Input 8 (-)</td><td>14</td><td>13</td><td>Input 7 (-)</td></tr> <tr><td>common</td><td>E8</td><td></td><td></td></tr> <tr><td>Input 6 (+)</td><td>12</td><td>11</td><td>Input 5 (+)</td></tr> <tr><td>Input 6 (-)</td><td>10</td><td>9</td><td>Input 5 (-)</td></tr> <tr><td>common</td><td>E6</td><td></td><td></td></tr> <tr><td>Input 4 (+)</td><td>8</td><td>7</td><td>Input 3 (+)</td></tr> <tr><td>Input 4 (-)</td><td>6</td><td>5</td><td>Input 3 (-)</td></tr> <tr><td>common</td><td>E4</td><td></td><td></td></tr> <tr><td>Input 2 (+)</td><td>4</td><td>3</td><td>Input 1 (+)</td></tr> <tr><td>Input 2 (-)</td><td>2</td><td>1</td><td>Input 1 (-)</td></tr> <tr><td>common</td><td>E2</td><td></td><td>common</td></tr> <tr><td>Thermistor (-)</td><td>B2</td><td>A2</td><td>Thermistor (+)</td></tr> <tr><td>Thermistor (-)</td><td>B1</td><td>A1</td><td>Thermistor (+)</td></tr> </table> <p>Terminals E1, E2, E4, E6, and E8 are electrically connected together, A1 and A2 are electrically connected together, B1 and B2 are electrically connected together</p>	Input 8 (+)	16	15	Input 7 (+)	Input 8 (-)	14	13	Input 7 (-)	common	E8			Input 6 (+)	12	11	Input 5 (+)	Input 6 (-)	10	9	Input 5 (-)	common	E6			Input 4 (+)	8	7	Input 3 (+)	Input 4 (-)	6	5	Input 3 (-)	common	E4			Input 2 (+)	4	3	Input 1 (+)	Input 2 (-)	2	1	Input 1 (-)	common	E2		common	Thermistor (-)	B2	A2	Thermistor (+)	Thermistor (-)	B1	A1	Thermistor (+)	<table border="0"> <tr><td>Input 8 (+)</td><td>16</td><td>15</td><td>Input 7 (+)</td></tr> <tr><td>Input 8 (-)</td><td>14</td><td>13</td><td>Input 7 (-)</td></tr> <tr><td>Input 6 (+)</td><td>12</td><td>11</td><td>Input 5 (+)</td></tr> <tr><td>Input 6 (-)</td><td>10</td><td>9</td><td>Input 5 (-)</td></tr> <tr><td>Input 4 (+)</td><td>8</td><td>7</td><td>Input 3 (+)</td></tr> <tr><td>Input 4 (-)</td><td>6</td><td>5</td><td>Input 3 (-)</td></tr> <tr><td>Input 2 (+)</td><td>4</td><td>3</td><td>Input 1 (+)</td></tr> <tr><td>Input 2 (-)</td><td>2</td><td>1</td><td>Input 1 (-)</td></tr> <tr><td>Thermistor (-)</td><td>B</td><td>A</td><td>Thermistor (+)</td></tr> </table>	Input 8 (+)	16	15	Input 7 (+)	Input 8 (-)	14	13	Input 7 (-)	Input 6 (+)	12	11	Input 5 (+)	Input 6 (-)	10	9	Input 5 (-)	Input 4 (+)	8	7	Input 3 (+)	Input 4 (-)	6	5	Input 3 (-)	Input 2 (+)	4	3	Input 1 (+)	Input 2 (-)	2	1	Input 1 (-)	Thermistor (-)	B	A	Thermistor (+)	<table border="0"> <tr><td>Input 5 (+)</td><td>11</td><td>10</td><td>Input 6 (-)</td></tr> <tr><td>Input 6 (+)</td><td>12</td><td>9</td><td>Input 5 (-)</td></tr> <tr><td>Input 7 (-)</td><td>13</td><td>8</td><td>Input 4 (+)</td></tr> <tr><td>Input 8 (-)</td><td>14</td><td>7</td><td>Input 3 (+)</td></tr> <tr><td>Input 7 (+)</td><td>15</td><td>6</td><td>Input 4 (-)</td></tr> <tr><td>Input 8 (+)</td><td>16</td><td>5</td><td>Input 3 (-)</td></tr> <tr><td>Thermistor (+)</td><td>A2</td><td>4</td><td>Input 2 (+)</td></tr> <tr><td>Thermistor (+)</td><td>A1</td><td>3</td><td>Input 1 (+)</td></tr> <tr><td>Thermistor (-)</td><td>B2</td><td>2</td><td>Input 2 (-)</td></tr> <tr><td>Thermistor (-)</td><td>B1</td><td>1</td><td>Input 1 (-)</td></tr> </table>	Input 5 (+)	11	10	Input 6 (-)	Input 6 (+)	12	9	Input 5 (-)	Input 7 (-)	13	8	Input 4 (+)	Input 8 (-)	14	7	Input 3 (+)	Input 7 (+)	15	6	Input 4 (-)	Input 8 (+)	16	5	Input 3 (-)	Thermistor (+)	A2	4	Input 2 (+)	Thermistor (+)	A1	3	Input 1 (+)	Thermistor (-)	B2	2	Input 2 (-)	Thermistor (-)	B1	1	Input 1 (-)
Input 8 (+)	16	15	Input 7 (+)																																																																																																																																			
Input 8 (-)	14	13	Input 7 (-)																																																																																																																																			
common	E8																																																																																																																																					
Input 6 (+)	12	11	Input 5 (+)																																																																																																																																			
Input 6 (-)	10	9	Input 5 (-)																																																																																																																																			
common	E6																																																																																																																																					
Input 4 (+)	8	7	Input 3 (+)																																																																																																																																			
Input 4 (-)	6	5	Input 3 (-)																																																																																																																																			
common	E4																																																																																																																																					
Input 2 (+)	4	3	Input 1 (+)																																																																																																																																			
Input 2 (-)	2	1	Input 1 (-)																																																																																																																																			
common	E2		common																																																																																																																																			
Thermistor (-)	B2	A2	Thermistor (+)																																																																																																																																			
Thermistor (-)	B1	A1	Thermistor (+)																																																																																																																																			
Input 8 (+)	16	15	Input 7 (+)																																																																																																																																			
Input 8 (-)	14	13	Input 7 (-)																																																																																																																																			
Input 6 (+)	12	11	Input 5 (+)																																																																																																																																			
Input 6 (-)	10	9	Input 5 (-)																																																																																																																																			
Input 4 (+)	8	7	Input 3 (+)																																																																																																																																			
Input 4 (-)	6	5	Input 3 (-)																																																																																																																																			
Input 2 (+)	4	3	Input 1 (+)																																																																																																																																			
Input 2 (-)	2	1	Input 1 (-)																																																																																																																																			
Thermistor (-)	B	A	Thermistor (+)																																																																																																																																			
Input 5 (+)	11	10	Input 6 (-)																																																																																																																																			
Input 6 (+)	12	9	Input 5 (-)																																																																																																																																			
Input 7 (-)	13	8	Input 4 (+)																																																																																																																																			
Input 8 (-)	14	7	Input 3 (+)																																																																																																																																			
Input 7 (+)	15	6	Input 4 (-)																																																																																																																																			
Input 8 (+)	16	5	Input 3 (-)																																																																																																																																			
Thermistor (+)	A2	4	Input 2 (+)																																																																																																																																			
Thermistor (+)	A1	3	Input 1 (+)																																																																																																																																			
Thermistor (-)	B2	2	Input 2 (-)																																																																																																																																			
Thermistor (-)	B1	1	Input 1 (-)																																																																																																																																			

Note: When connecting a thermistor to an I/O terminal block, it is important to be sure that no other connection is made to the thermistor terminals.

Using an Optional Thermocouple Terminal Block

The Thermocouple Terminal Block (IC670CHS004), which has two built-in thermistors, can be used to provide local reference junction compensation. The Thermocouple Terminal Block is installed in the same manner as other Field Control I/O Terminal Blocks.

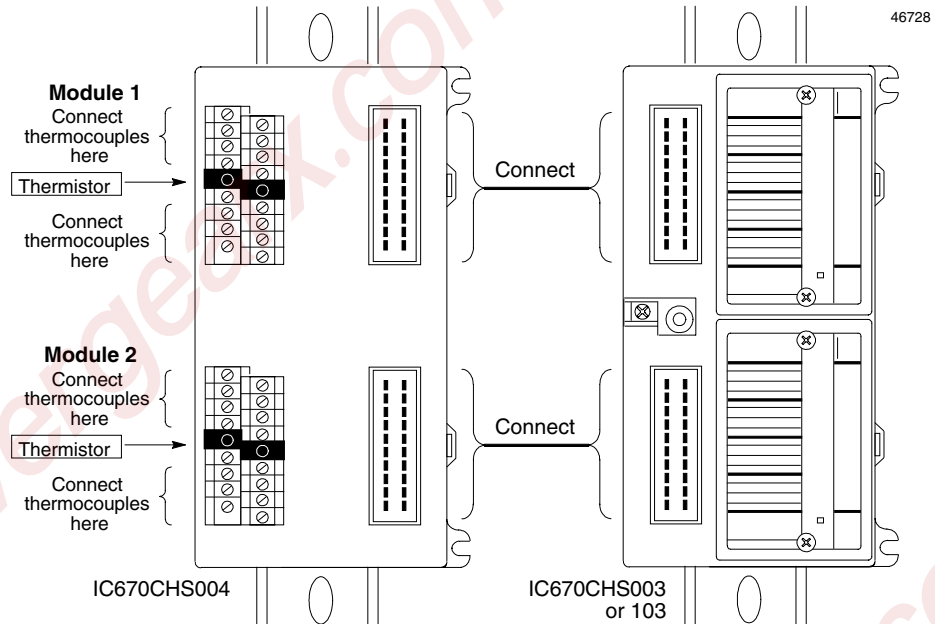

Caution

The Thermocouple Terminal Block must be used with a grounded conductive DIN rail to assure that the assembly screws in the terminal block base cover are connected to chassis ground.

Connecting Thermocouples to a Thermocouple Terminal Block

For each module, the connector pin assignments on terminal block IC670CHS004 with the base mounted in the position shown above are:

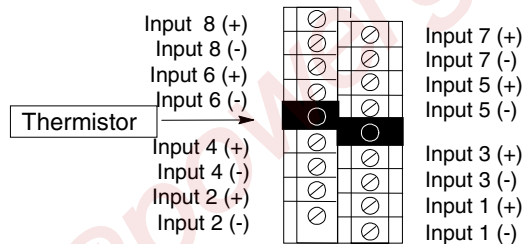

Connecting a Thermocouple Terminal Block to the I/O Terminal Block

Connect a Thermocouple Terminal Block (IC670CHS004) to the I/O Terminal block (IC670CHS003) using an appropriate cable. The diagram below shows the pin assignments for each Wire to Board connector on the Thermocouple Terminal Block (IC670CHS004).

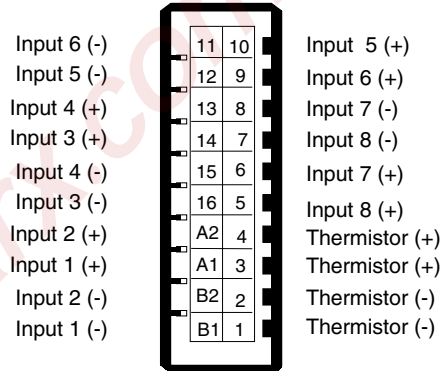
**Using a Crimping Tool**

Pins (catalog number IC670ACC003) must be installed on individual wires using a crimping tool. The AMP™ Pro-Crimper™ II, Hand Tool Assembly 90546-1 is recommended. The tool must be properly adjusted, as detailed in the instructions that come with the tool.

1. Strip the wire 3.96 to 4.75mm (0.156 to 0.187in), taking care not to nick or cut wire strands.
2. Hold the tool with the back (wire side) facing you. Squeeze tool handles together and allow them to open fully.
3. Holding the contact by the mating end, insert the contact-insulation barrel first-through the front of the tool into the appropriate crimp section. Position the contact with the mating end on the locator side of the tool, so that the open "U" of the wire and insulation barrels face the top of the tool. Place the contact up into the nest so that the movable locator drops into the slot in the contact. Butt the front end of the wire barrel against the movable locator.

NOTE: Be sure both sides of the insulation barrel are started evenly into the crimping section. DO NOT attempt to crimp an improperly-positioned contact.

4. Hold the contact in position and squeeze the tool handles together until ratchet engages enough to hold the contact in position. DO NOT deform insulation barrel or wire barrel.
5. Insert stripped wire into contact until it is butted against wire stop as shown.
6. Holding wire in place, squeeze tool handles together until ratchet releases.
7. Check the contact's crimp height as described in the tool instruction sheet. Adjust the crimp height if necessary before continuing.

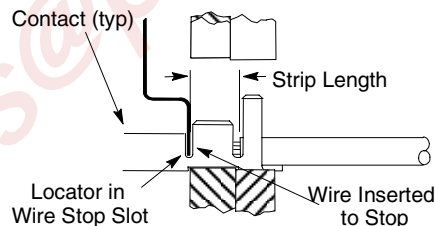

Diagnostics

The Thermocouple module performs diagnostics and provides the diagnostic data to the Bus Interface Unit's discrete input (I) table.

The module sets the appropriate bit when a diagnostic condition is detected. The bit remains set until it is cleared.

Alarm bits are set if the processed value for a channel exceeds its configured alarm limit.

Overrange bits are set if the millivolt value for an input exceeds the limits of its span.

Open circuit is checked every time a thermocouple input is read (unless Open TC checking is disabled). If the circuit is open, the corresponding bit is set, and the input is not processed further.

Circuit Diagnostics Bits (byte 0)

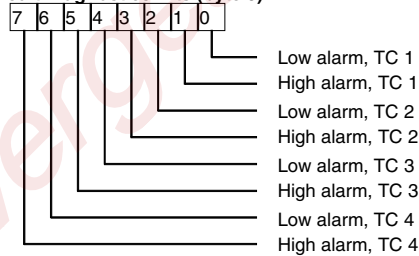

Circuit Diagnostics Bits (byte 1)

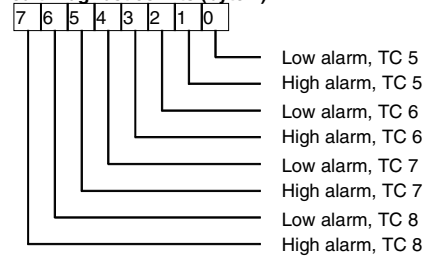

Circuit Diagnostics Bits (byte 2)

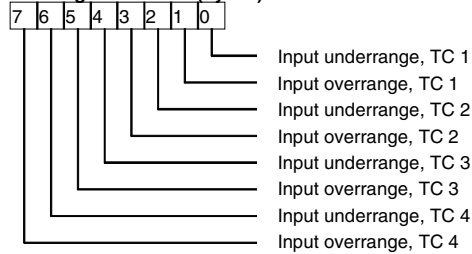

Circuit Diagnostics Bits (byte 3)

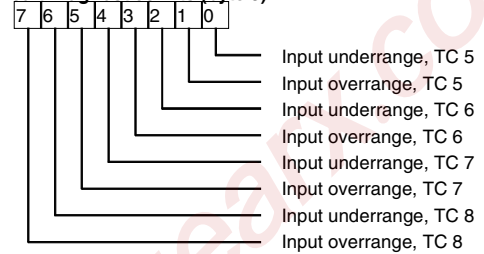

Circuit Diagnostics Bits (byte 4)

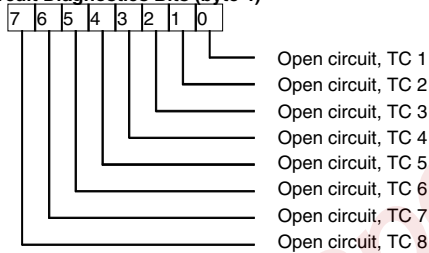

Circuit Diagnostics Bits (byte 5)

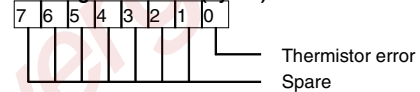

Clearing Faults and Alarms

The host can use a set of 16 discrete output bits in the BIU's discrete output (Q) table to clear and inhibit faults and alarms for the Thermocouple Input module. Setting the appropriate bit from the host clears all diagnostic bits for that thermocouple that may be set.

The discrete input bits for a channel remain clear in the BIU as long as the corresponding discrete output bit is set.

Output Command Bits to Clear Diagnostics (byte 0)

7	6	5	4	3	2	1	0
---	---	---	---	---	---	---	---



Output Command Bits to Clear Diagnostics (byte 1)

7	6	5	4	3	2	1	0
---	---	---	---	---	---	---	---

Clear Errors for Thermistor

A thermistor error occurs if the calculated temperature value from the thermistor is less than -10 degrees C or greater than +75 degrees C.

Chapter 22

8 Point Isolated Analog Voltage-Source Output Module IC670ALG310

The 8 Point Isolated Analog Voltage-source Output Module (IC670ALG310) accommodates eight voltage outputs in two isolated groups of four. It provides eight channels of analog voltage outputs with user-configurable scaling for each channel.

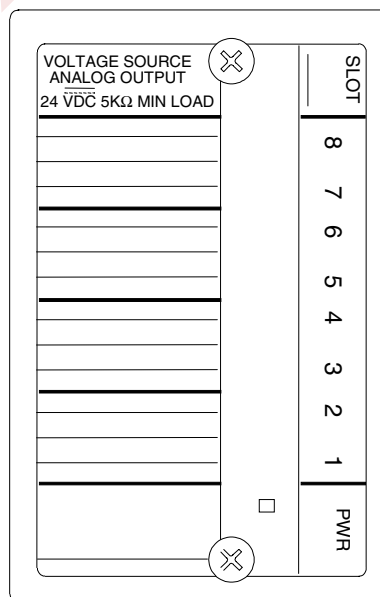

- Supports 8 channels of output voltages ranging from -10V to +10V with 14-bit resolution.
- Output overrange provided for up to approximately 10.25V.
- Uses both word and bit data types.
- Can be field-recalibrated or reset to factory calibration. Calibration data stored in FLASH memory.
- Individual channel configuration including output range and scaling parameters.
- Reports Under/Overage faults.

Power Sources

The 8 Point Isolated Analog Voltage-source Output Module requires a separate source of power for the outputs.

LEDs

A single indicator shows module status:

- ON: normal operation
- Intermittent flashing: module fault
- OFF: No backplane power, no user power, or fatal fault.

Module Operation

During operation, the module receives engineering units output data from the Bus Interface Unit (BIU). It scales this data according to its calibration and configured scaling parameters, then converts the data to output voltage in the range of -10V to +10V.

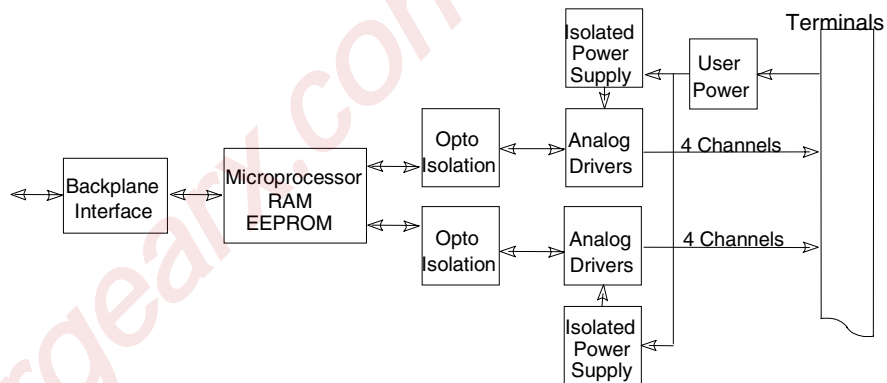

The 8 Point Isolated Analog Voltage-source Output Module provides the following alarms:

- **Over/Underrange:** if an engineering units value sent by the host has resulted in an output value within approximately 50mV of the module's maximum or minimum.
- **Loss of User Power**
- **Uncalibrated Module**

If an alarm occurs, the module sets a bit in its optional discrete input data. These alarm bits can be monitored by the application logic. They can be reset by sending appropriate alarm-clearing discrete output data to the module.

Host Interface

The 8 Point Isolated Analog Voltage-source Output Module uses the following types of data:

- 0-8 words of analog output data
- 0-3 bytes of discrete input data for module and channel status.
- 0-2 bytes of discrete output data for clearing alarms.

The module exchanges data with a Bus Interface Unit in the same manner as other types of I/O modules-it provides all its input data and status bits when requested by the BIU, and receives fault-clearing commands and analog output data from the BIU.

The module can also be configured for "Group" data transfer with the BIU or with other intelligent devices in the same Field Control station. Group data is described in the *Bus Interface Unit User's Manual*.

Compatibility

This module must be used with a Bus Interface Unit revision 2.0 or later.

8 Point Isolated Analog Voltage-Source Output Module

Module Configuration Overview

Like other Field Control modules, the 8 Point Isolated Analog Voltage-source Output Module is usually configured from the Bus Interface Unit, using a compatible hand-held programmer. The module's configuration can also be read or written from the bus in a system which supports such configuration. The table below summarizes configuration choices and defaults. The module will power up with the default configuration settings. For configuration instructions, refer to the *Bus Interface Unit User's Manual*.

Module Parameter	Description	Default	Choices
Analog Output Data Length	Length in words for the module's analog output data in the BIU's analog output (AQ) table.	8 words	0-8
Analog Output Reference	Starting offset for the module's analog output data in the BIU's analog output (AQ) table.		User selected
Discrete Input Data Length	Length in bits for the module's optional discrete input diagnostic data in the BIU's discrete input (I) table.	24 bits	0, 8, 16, 24
Discrete Input Reference	Starting offset for the module's diagnostic data in the BIU's discrete input (I) table.		User selected
Discrete Output Data Length	Length in bits of the module's optional discrete output fault clearing data in the BIU's discrete output (Q) table.	16 bits	0, 8, 16
Discrete Output Reference	Starting offset for the module's fault clearing data in the BIU's discrete output (Q) table.		User selected
(BIU) Defaults: Input data	If the BIU loses communications with the module, the module's discrete input (diagnostic) data can be set to zero or hold its last state.	Zero	Zero, Hold Last State
(BIU) Defaults: Output data	If the BIU loses communications with the network, the module's discrete (fault clearing) and analog output data can be set to zero or hold its last state.	Zero	Zero, Hold Last State
Local Defaults: Outputs	If a reset or local failure occurs, the module can set the actual outputs to zero or hold their last values (this requires local power).	Zero	Zero, Hold Last State
Channel Active	Whether a channel will respond to commanded analog and discrete output data and return alarms. If a channel is inactive its output is zero. If a previously-active channel is reconfigured as inactive, any pre-existing alarms can still be cleared using Q data.	Active	Inactive, Active
Range	There are two preset scaling ranges. +/-10V (bipolar) range: span and engineering units from +/- 10,000. 0 to 10V (unipolar) range: span and engineering units from 0 to 10,000.	+/- 10V	+/-10V, 0 to 10V
Span Low	Actual voltage in millivolts to be scaled to low engineering units.	-10,000	-16,384 to +16,383
Span High	Actual voltage in millivolts to be scaled to high engineering units.	+10,000	
Engineering Low	Engineering units equivalent of the low span value.	-10,000	
Engineering High	Engineering units equivalent of the high span value.	+10,000	

Module Features

Channel Active

Each channel can be configured as either active or inactive.

If a channel is Inactive, its output is 0V and the analog output data for the channel is not used. Alarm (optional discrete input) data for the channel is not updated for a channel that has been configured as Inactive.

If the configuration of a channel is changed from Active to Inactive, the module stops updating its alarm data. Pre-existing alarms can still be cleared using the module's configured discrete output bits.

Local Output Defaults

In addition to being able to configure data defaults of zero or hold last state for the module's data in the BIU, local output defaults for the module are also configurable. These module local defaults determine whether the module will set the actual output voltages to zero volts or hold their last values if a module error occurs.

Hold Last State

If the output default of a channel is Hold Last State and user power is present, the channel output holds its last value if:

1. The BIU resets the module.
2. No output data is received from the BIU within the BIU Timeout period.
3. Backplane power is lost.
4. The module's watchdog timer expires.

Outputs will continue to hold their last states until the module receives output data from the BIU or until user power is removed.

8 Point Isolated Analog Voltage-Source Output Module

Scaling

Scaling defines the constant-slope mapping from the value in engineering units sent by the BIU to a channel's output voltage. There are two preset scaling ranges: +/-10 volts and 0 to 10 volts.

The default range selection of +/-10 volts is for bipolar scaling. Both the span and engineering units can range from -10,000 to +10,000 millivolts.

The other preset range, 0 to +10 volts is for unipolar scaling, gives both span and engineering units of 0 to +10,000 millivolts.

The illustration below represents the two preset ranges.

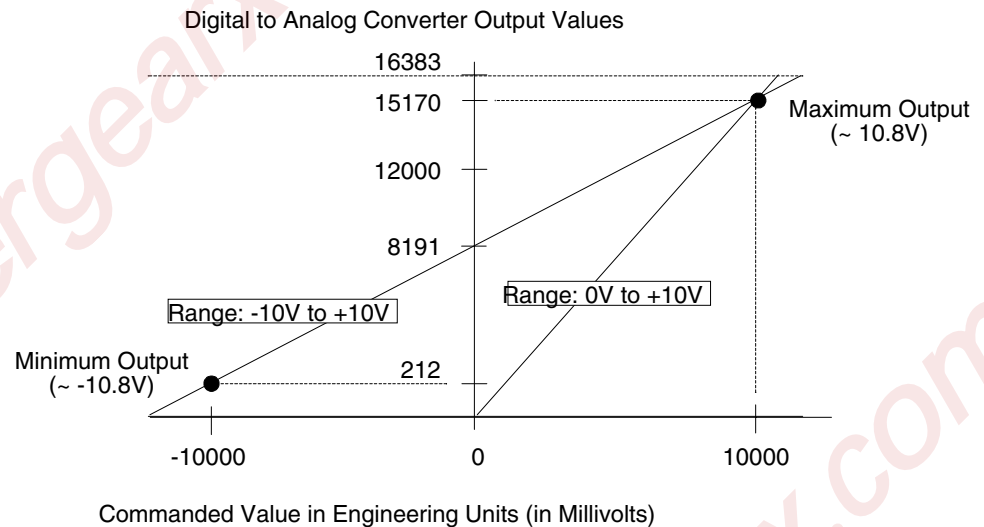

After selecting either the bipolar or unipolar range (see above), scaling for each point can be customized by changing its high or low engineering units and/or output (span) values.

The scaling values selected do not restrict the hardware output range.

Module Specifications

Module Characteristics	
Number of channels (single ended)	8
Power supply range (see note 1)	18 to 30 VDC, 24 VDC typical. 5% maximum ripple
Operating temperature range	0 to 55 degrees C ambient
Isolation to ground and logic	1500 VAC peak for 1 minute, 250 VAC continuous
Current Drawn from BIU power supply	170 mA maximum
Current Drawn from external power supply	275 mA maximum at 18V, all outputs -10V into minimum load
Output Characteristics	
Resolution	14 bits
Magnitude data size	14 bits
Accuracy (see note): at 25deg. C from 0 to +55 deg. C	0.15% of full scale (maximum) 0.25% of full scale (maximum)
Output Range Limits:	-10.25V to +10.25V
Analog resolution	~ □mV per count, maximum resolution
Output load capacitance	1μF maximum
User Load	5000 Ohms minimum
Update time	1.5 mS typical

note: In the presence of severe RF interference (IEC 801-3, 10V/m), accuracy may be degraded to $\pm 2\%$ tolerance.

Keying Locations

Optional keying locations for the 8 Point Isolated Analog Voltage-source Output Module are:

Keying Locations									
A	B	C	D	E	F	G	H	J	K
x			x					x	x

8 Point Isolated Analog Voltage-Source Output Module

Field Wiring

Instrumentation grade Shielded Twisted Pair wire should be used for best noise immunity. The shield should be terminated at a local panel ground near the module. The following illustration shows typical connections for this module.

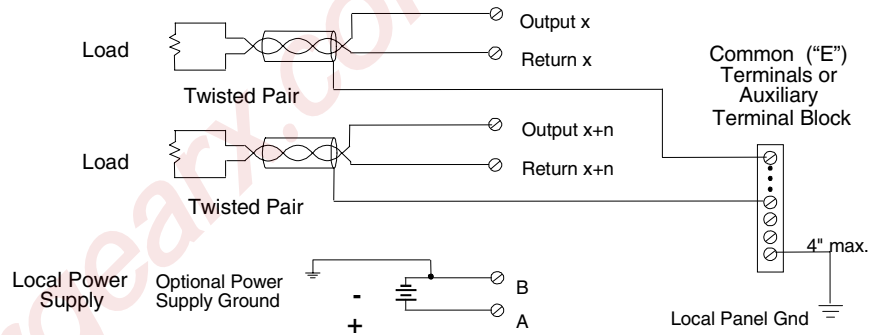

An Auxiliary Terminal Block can be used to provide additional wiring terminals for the shields. Auxiliary Terminal Blocks have all terminals connected together internally. The Auxiliary Terminal Block with box terminals (IC670TBM002) has 13 terminals; each accommodates one AWG #14 (avg 2.1mm² cross section) to AWG #22 (avg 0.36mm² cross section) wire. The Auxiliary Terminal Block with barrier terminals (IC670TBM001) has nine terminals; each can accommodate one or two wires up to AWG #14 (avg 2.1mm² cross section).

I/O Terminal Block Terminal Assignments

An Terminal Block with Box Terminals has 25 terminals per module. Each accommodates one AWG #14 (avg 2.1mm² cross section) to AWG #22 (avg 0.36mm² cross section) wire, or two wires up to AWG #18 (avg. 0.86mm² cross section). If an external jumper is used, single-wire capacity is reduced from AWG #14 (2.10mm²) to AWG #16 (1.32mm²).

An I/O Terminal Block with Barrier Terminals has 18 terminals per module. Each terminal can accommodate one or two wires up to AWG #14 (avg 2.1mm² cross section).

An I/O Terminal Block with Connectors has one 20-pin male connector per module.

All Return terminals are common to each other.

I/O Terminal Block with Box Terminals (IC670CHS002 or 102)	I/O Terminal Block with Barrier Terminals (IC670CHS001 or 101)	I/O Terminal Block with Wire to Board Connectors (IC670CHS003 or 103)																																																																																																																																								
<table border="0"> <tr><td>Return B</td><td>16</td><td>15</td><td>Return B</td></tr> <tr><td>Output B4</td><td>14</td><td>13</td><td>Output B3</td></tr> <tr><td>Common</td><td>E8</td><td></td><td></td></tr> <tr><td>Output B2</td><td>12</td><td>11</td><td>Output B1</td></tr> <tr><td>Return B</td><td>10</td><td>9</td><td>Return B</td></tr> <tr><td>Common</td><td>E6</td><td></td><td></td></tr> <tr><td>Return A</td><td>8</td><td>7</td><td>Return A</td></tr> <tr><td>Output A4</td><td>6</td><td>5</td><td>Output A3</td></tr> <tr><td>Common</td><td>E4</td><td></td><td></td></tr> <tr><td>Output A2</td><td>4</td><td>3</td><td>Output A1</td></tr> <tr><td>Return A</td><td>2</td><td>1</td><td>Return A</td></tr> <tr><td>Common</td><td>E2</td><td></td><td></td></tr> <tr><td>User Return</td><td>B2</td><td>A2</td><td>Common</td></tr> <tr><td>User Return</td><td>B1</td><td>A1</td><td>+24V nominal</td></tr> <tr><td></td><td></td><td></td><td>+24V nominal</td></tr> </table> <p>Terminals E1, E2, E4, E6, and E8 are electrically connected together, A1 and A2 are electrically connected together, B1 and B2 are electrically connected together.</p>	Return B	16	15	Return B	Output B4	14	13	Output B3	Common	E8			Output B2	12	11	Output B1	Return B	10	9	Return B	Common	E6			Return A	8	7	Return A	Output A4	6	5	Output A3	Common	E4			Output A2	4	3	Output A1	Return A	2	1	Return A	Common	E2			User Return	B2	A2	Common	User Return	B1	A1	+24V nominal				+24V nominal	<table border="0"> <tr><td>Return B</td><td>16</td><td>15</td><td>Return B</td></tr> <tr><td>Output B4</td><td>14</td><td>13</td><td>Output B3</td></tr> <tr><td>Output B2</td><td>12</td><td>11</td><td>Output B1</td></tr> <tr><td>Return B</td><td>10</td><td>9</td><td>Return B</td></tr> <tr><td>Return A</td><td>8</td><td>7</td><td>Return A</td></tr> <tr><td>Output A4</td><td>6</td><td>5</td><td>Output A3</td></tr> <tr><td>Output A2</td><td>4</td><td>3</td><td>Output A1</td></tr> <tr><td>Return A</td><td>2</td><td>1</td><td>Return A</td></tr> <tr><td>User Return</td><td>B</td><td>A</td><td>+24V nominal</td></tr> </table>	Return B	16	15	Return B	Output B4	14	13	Output B3	Output B2	12	11	Output B1	Return B	10	9	Return B	Return A	8	7	Return A	Output A4	6	5	Output A3	Output A2	4	3	Output A1	Return A	2	1	Return A	User Return	B	A	+24V nominal	<table border="0"> <tr><td>Output B1</td><td>11</td><td>10</td><td>Return B</td></tr> <tr><td>Output B2</td><td>12</td><td>9</td><td>Return B</td></tr> <tr><td>Output B3</td><td>13</td><td>8</td><td>Return A</td></tr> <tr><td>Output B4</td><td>14</td><td>7</td><td>Return A</td></tr> <tr><td>Return B</td><td>15</td><td>6</td><td>Output A4</td></tr> <tr><td>Return B</td><td>16</td><td>5</td><td>Output A3</td></tr> <tr><td>+24V nominal</td><td>A2</td><td>4</td><td>Output A2</td></tr> <tr><td>+24V nominal</td><td>A1</td><td>3</td><td>Output A1</td></tr> <tr><td>User Return</td><td>B2</td><td>2</td><td>Return A</td></tr> <tr><td>User Return</td><td>B1</td><td>1</td><td>Return A</td></tr> </table>	Output B1	11	10	Return B	Output B2	12	9	Return B	Output B3	13	8	Return A	Output B4	14	7	Return A	Return B	15	6	Output A4	Return B	16	5	Output A3	+24V nominal	A2	4	Output A2	+24V nominal	A1	3	Output A1	User Return	B2	2	Return A	User Return	B1	1	Return A
Return B	16	15	Return B																																																																																																																																							
Output B4	14	13	Output B3																																																																																																																																							
Common	E8																																																																																																																																									
Output B2	12	11	Output B1																																																																																																																																							
Return B	10	9	Return B																																																																																																																																							
Common	E6																																																																																																																																									
Return A	8	7	Return A																																																																																																																																							
Output A4	6	5	Output A3																																																																																																																																							
Common	E4																																																																																																																																									
Output A2	4	3	Output A1																																																																																																																																							
Return A	2	1	Return A																																																																																																																																							
Common	E2																																																																																																																																									
User Return	B2	A2	Common																																																																																																																																							
User Return	B1	A1	+24V nominal																																																																																																																																							
			+24V nominal																																																																																																																																							
Return B	16	15	Return B																																																																																																																																							
Output B4	14	13	Output B3																																																																																																																																							
Output B2	12	11	Output B1																																																																																																																																							
Return B	10	9	Return B																																																																																																																																							
Return A	8	7	Return A																																																																																																																																							
Output A4	6	5	Output A3																																																																																																																																							
Output A2	4	3	Output A1																																																																																																																																							
Return A	2	1	Return A																																																																																																																																							
User Return	B	A	+24V nominal																																																																																																																																							
Output B1	11	10	Return B																																																																																																																																							
Output B2	12	9	Return B																																																																																																																																							
Output B3	13	8	Return A																																																																																																																																							
Output B4	14	7	Return A																																																																																																																																							
Return B	15	6	Output A4																																																																																																																																							
Return B	16	5	Output A3																																																																																																																																							
+24V nominal	A2	4	Output A2																																																																																																																																							
+24V nominal	A1	3	Output A1																																																																																																																																							
User Return	B2	2	Return A																																																																																																																																							
User Return	B1	1	Return A																																																																																																																																							

Diagnostics Data

The 8 Point Isolated Analog Voltage-source Output Module performs diagnostics and provides 24 bits (3 bytes) of diagnostic data to the BIU. Data is placed in the BIU's discrete input (I) data table starting at the configured reference. The module sets the appropriate bit of this data when a diagnostic condition is detected. Diagnostics bits remain set until cleared by the appropriate data outputs, as described below. The condition causing the fault must be corrected, or the module will set the bit again. Use of this data is optional. The module is easily configured to use all, some, or none of the diagnostic data.

Module Diagnostics Bits (byte 0)

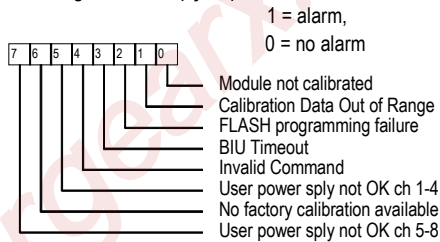

Channel Under/Overrange Bits (byte 2)

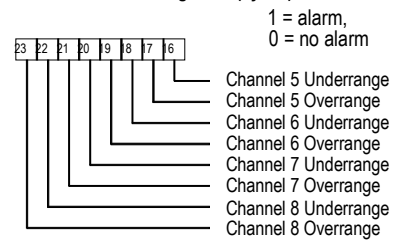

Channel Under/Overrange Bits (byte 1)

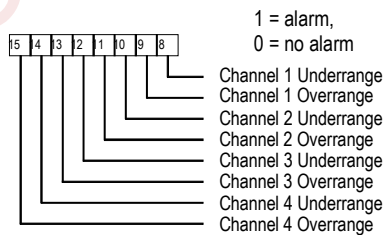

Clearing Faults and Alarms

The BIU uses two bytes of discrete output data to clear the module fault and alarm bits. The fault-clearing bits start at the module's configured discrete output reference in the BIU's discrete output (Q) table. Setting a bit in the first byte of discrete output data to 1 clears the over/underrange alarms for the corresponding channel (even if the alarm conditions are still present).

Bits #0-2, 4, and 6 in the module diagnostics byte are calibration-related and should never be set during normal operation. These bits cannot be cleared using discrete output (Q) data. If any of these bits is set during normal operation (not during calibration), a problem exists and the module should be returned.

Output Command Bits to Clear Alarms (byte 0)

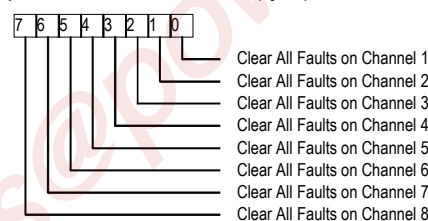

byte 1

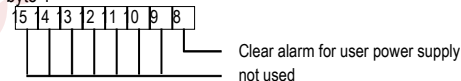

Chapter 23

Current/Voltage-Source Analog Output Module IC670ALG320

The Analog Output Module (IC670ALG320) provides a group of four current/voltage analog outputs. Each output channel provides a span of 4-20mA and 0-10V, which can be changed to 0-20mA and 0-12.5 volts by adding jumper on the I/O Terminal Block. Default scaling is 0 to 20,000. Scaling can be changed in configuration to match the output used or to engineering units.

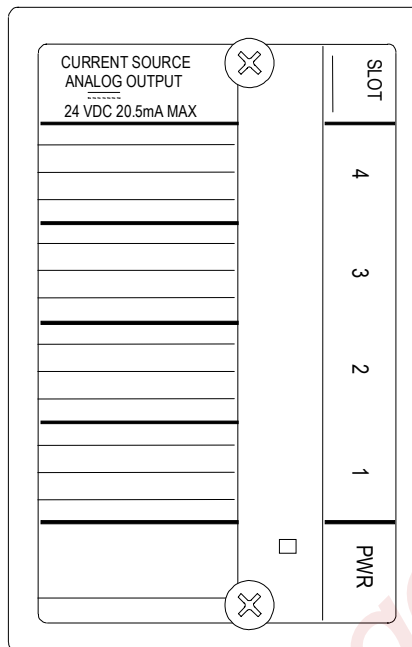

Power Sources

The same 24 volt power supply used for the Bus Interface Unit can provide loop power to the outputs in most cases. If module to module (or Bus Interface Unit) isolation is required, separate power supply(s) must be used.

The most common application would have the loop supply local at the module, driving multiple isolated transducers, isolated analog inputs, or differential analog inputs.

LED

An LED, visible through the transparent portion of the module top, indicates whether field and backplane power are present.

Host Interface

The Current Source Analog Output Module has 4 words (8 bytes) of analog output data. A Bus Interface Unit is required to provide this output data to the host and/or local processor.

The module converts analog values from the host or local processor into output current. Scaling for the module is performed by the Bus Interface Unit. Software Range Selection of 0 to 20mA and 4 to 20mA is available on a per-channel basis. Using the 0 to 20 mA range requires the installation of an external wire jumper between JMP and RET.

The default scaling for this module is:

0-20mA Range		4-20mA Range	
Eng Lo =	0	Eng Lo =	0
Eng Hi =	20,000	Eng Hi =	20,000
Int Lo =	0	Int Lo =	4,000
Int Hi =	20,000	Int Hi =	20,000

The default range is 0 to 20mA. The module is shipped with no wire jumper present. The jumper must be installed to correspond to the module's default range and scaling.

The 4-20mA range provides a fixed 4 milliamp offset (0mA = 4mA signal), with a 16mA signal span. The 4mA offset remains as long as analog loop power is applied, even if the logic power is off. Note that default outputs for loss of host communications require both backplane power and analog field power.

A second output on each channel provides an uncalibrated voltage output. The 4 to 20mA range corresponds to 0 to 10 volts. The 0 to 20 mA range corresponds to 0 to 12.5-volts. A wire jumper is required for the 0 to 20mA range. Both voltage ranges have restricted load current drive capability above 10 volts. Voltage can be used alone, or simultaneously with current to drive meters or voltage input devices.

An OPEN WIRE diagnostic available per channel operates only on the current outputs. If you are using only the voltage output of a channel, you should either disable the fault or connect a dummy load of 250 to 800 ohms across the current terminals of the channel. An OPEN WIRE fault will not affect the operation of the voltage output.

Output register values outside the capability of the module will drive the output to the appropriate minimum or maximum level but will not generate a diagnostic fault.

Keying Locations

Optional keying locations for the Current Source Analog Output Module are:

Keying Locations									
A	B	C	D	E	F	G	H	J	K
x		x						x	x

Scaling

The “Int” units on the HHM configuration screen correspond to actual desired output current values, in microamps, provided the base terminal jumper corresponds to the module range configuration. The Int unit values set in the configuration must be within the limits of the range used. The module will operate with a range-jumper mismatch, but Int units scaling will be invalid. The “Eng” units are the values supplied by the host.

Field Recalibration Using Scaling

Field recalibration can be accomplished by forcing the outputs to the “Eng Hi” and/or “Eng Lo” calibration point values in the module configuration, reading the actual output produced, and updating the configured values to the actual values. Usually, recalibrating the high point only is sufficient. If the low point is done, it should be changed from the default value of 0 volts or 4000 microAmps to get better accuracy. The following example shows a two-point calibration for 0 to 10 volts:

1. Set the analog output scaling for 0 to 10 volts output:

Eng lo	100	(mV)
Eng hi	10,000	(mV)
Internal lo	4,160	(corresponds to 100 mV)
Internal hi	20,000	(corresponds to 100 mV)

2. Force the output to the low point value: 100 (= 0.100 volt)
3. Read the output using an accurate meter on the output. For example, you might get a value of 0.107 volts, instead of 100.
4. Force the output to the high point value: 10000 (=10.000 volts)
5. Read the output using an accurate meter on the output. For example, you might get a value of 9.985 volts, instead of 10.000 volts.
6. Change the scaling to the new calibrated values:

Eng lo	107	(reading in mV from step 3)
Eng hi	9985	(reading in mV from step 5)
Internal lo	4160	(microamps to yield voltage in step 2)
Internal hi	20000	(microamps to yield voltage in step 4)

7. The voltage output is now calibrated to your meter, within the approximately 3-millivolt resolution of the output.

Use the new Eng Hi and Eng Lo values as calibration points when repeating, or go back to step 1 and begin again. The scaling affects both the voltage and current forms of the output point, so only one can be recalibrated.

Module Operation

Four D/A converters provide simultaneous current and voltage outputs from each output channel. Current output spans are 0-20 or 4-20 mA; voltage spans are 0-10 or 0-12.5 volts. All outputs are isolated from ground and logic, but are grouped on a common power supply. Outputs can be isolated as a group from the rest of the system if a separate isolated loop supply is used.

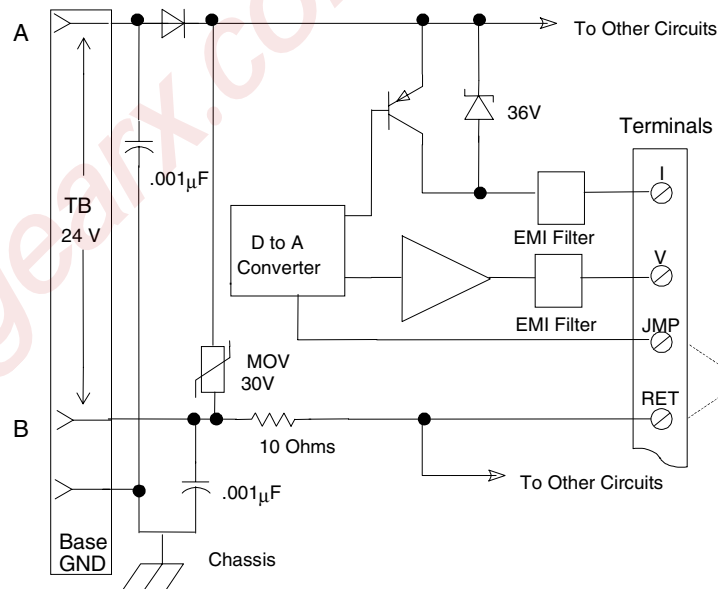

Each circuit provides simultaneous voltage and current outputs from the digital to analog converter. All circuits share a common loop supply and return.

The current driver is a sourcing type. The low side of a load can be connected to RET, the negative side of a 24 V loop supply, or a more negative point that can be up to 36 volts negative with respect to the module 24 volt supply positive terminal.

Voltage output is relative to RET terminal, which is common to all circuits. The module's 10 ohm resistor helps reduce ground loop circulating currents.

The operating range for an output can be changed to 0-20 mA, 0-12.5 volt by connecting the JMP terminal to the RET terminal for that output.

The module contains MOV transient voltage suppressors, and RF bypass capacitors to the module chassis. The chassis point is connected to the module case and the chassis ground terminal on the module base. This should be grounded for best noise immunity.

Outputs default to minimum value upon initial powerup or loss of backplane power.

Module Specifications

Module Characteristics	
Linearity, all ranges & outputs	1 LSB resolution value
Power supply range	20 to 29 volts, DC, 5% maximum ripple
24V Power input current Standby (no output) Operating	80 mA typical 180 mA (including loop current), maximum
Module power dissipation	1.5 Watts, minimum, 4.3 Watts maximum
Temperature coefficient	+/- .002% of value per degree C, typical, +/- .005% of value per degree C, maximum
Isolation to ground and logic	1500 VAC for 1 minute, 250 VAC continuous
Input or channel to channel common mode	None; single ended grouped out
Current Drawn from BIU Power Supply	51 mA maximum
Output Characteristics	
Digital Resolution	12 bits, typical
Current Analog Resolution, LSB current 4 - 20 range 0 - 20 range Output current range JMP open JMP to RET Current load impedance Open wire (current only) Over-range Output error, current (note 4)	4.0 microAmps, typical 5.0 microAmps, typical 4 mA, minimum, 20mA maximum 0.05 mA minimum, 20mA maximum (note 1) 0 Ohms minimum, 600 Ohms maximum (note 2) 800 load Ohms minimum (note 3) 20.000 mA minimum, 20.500 mA maximum +/-20µA +/-0.1% of value, maximum
Voltage Analog Resolution, LSB voltage 0-10 0-12.5 Output voltage range JMP open JMP to RET Voltage load impedance Output error, voltage (note 4)	2.5 mV typical 3.125mV typical 0.02 Volts minimum, 10 Volts maximum (note 1) 0.02 Volts minimum, 12.5 Volts maximum 2K Ohms minimum for 10V output, 5 K for 12.5V output +/-10mV +/-0.25% of value, maximum

note 1: May limit or become non-linear below minimum values given, due to saturation of output drivers.

note 2: Minimum load should be 250 ohms if ambient exceeds 50deg. C. Valid over rated 18-30 supply voltage. Maximum load can be increased to 800 ohms if min. supply voltage is greater than 23.0 volts, including ripple.

note 3: Open wire occurs when there is insufficient compliance voltage to drive output to commanded value. Therefore occurrence of open wire depends on combination of output load and current. The open wire warning may occur continuously on a disconnected output, such as not used, or voltage used instead.

note 4: In the presence of severe RF interference (IEC 801-3, 10V/m), accuracy may be degraded to 1mA or 0.5V.

Field Wiring

The following illustration shows typical connections for this module.

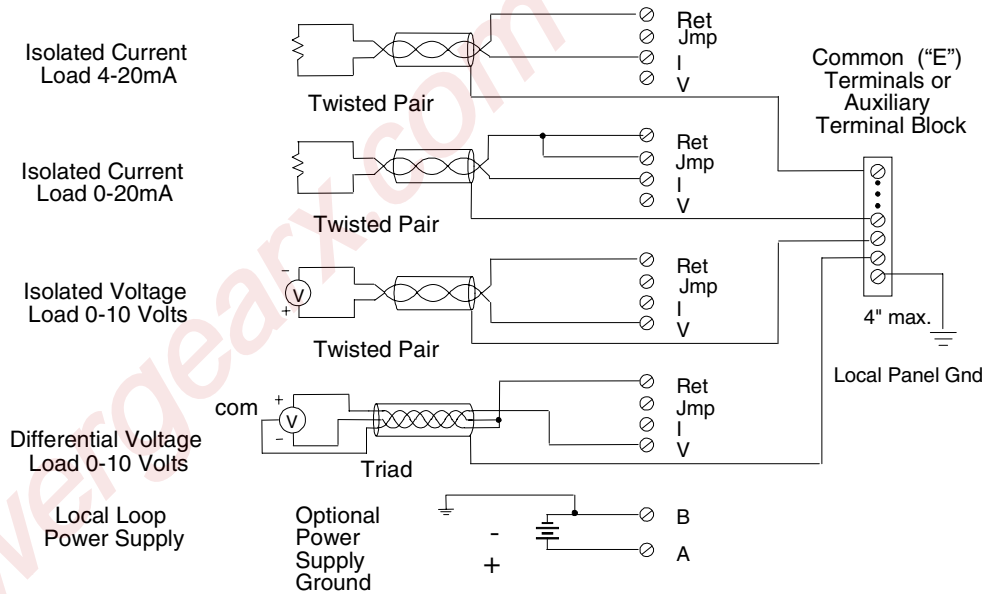

Instrumentation grade shielded twisted pair or 3 wire twisted (triad) wire should be used for best noise immunity. The shield should be terminated at a local panel ground near the module.

The module local loop supply may be either floating or grounded, and may be shared with other similar functions. All loads have a common return bus (RET) available at the module for the negative side of the loads. This is internally connected through a 10-Ohm buffer resistor to the supply negative side B terminal. Normally, only ungrounded loads are recommended.

If a grounded load must be driven, a circulating ground loop current may be set up between the load and ungrounded module supply. (This may reduce accuracy). The internal resistance lessens the effect for small ground voltage differences.

CAUTION

The module may be damaged if high ground voltage differences occur due to miswiring or high power surges.

Ordinarily no additional wiring to the RET bus is needed. However, if a low-impedance ground is required to all devices, the proper way is to jumper any RET terminal to the power B terminal at the module and ground the Loop supply externally.

Auxiliary Terminal Block may be used to provide additional wiring terminals. For the I/O Terminal Block with Wire to Board Connectors, external connection points are usually preferred, although an Auxiliary Terminal Block can be used.

Auxiliary Terminal Blocks have all terminals connected together internally. The Auxiliary Terminal Block with box terminals has 13 terminals, each of which accommodates one AWG #14 (avg 2.1mm² cross section) to AWG #22 (avg 0.36mm² cross section) wire, or two wires up to AWG #18 (avg. 0.86mm² cross section). The Auxiliary Terminal Block with barrier terminals has nine terminals, each of which can accommodate one or two wires up to AWG #14 (avg 2.1mm² cross section).

The Panel Ground Shield from the Auxiliary Terminal Block to the panel should be AWG #14 wire, not longer than 4 inches (10cm).

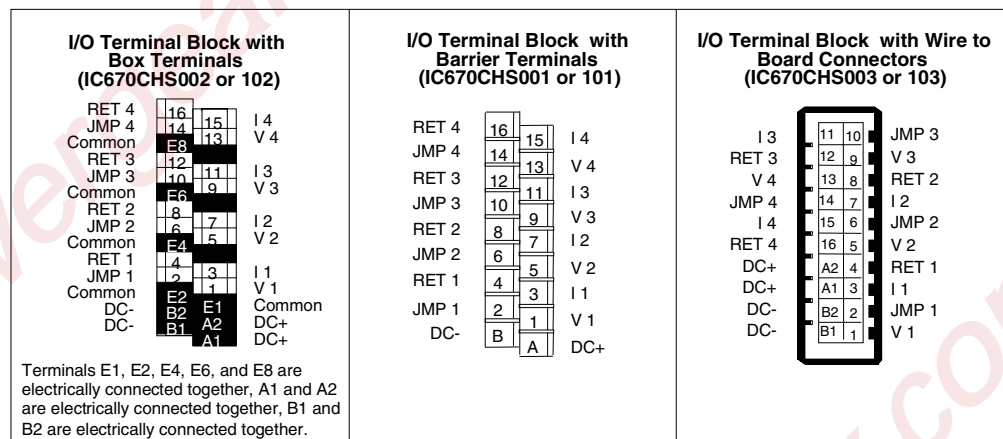

Chapter 24

8 Point Current-Source Analog Output Module IC670ALG330

The 8 Point Analog Current-source Output Module (IC670ALG330) accommodates 8 current-loop outputs on a common power supply. It provides eight channels of analog current outputs with user-configurable scaling for each channel.

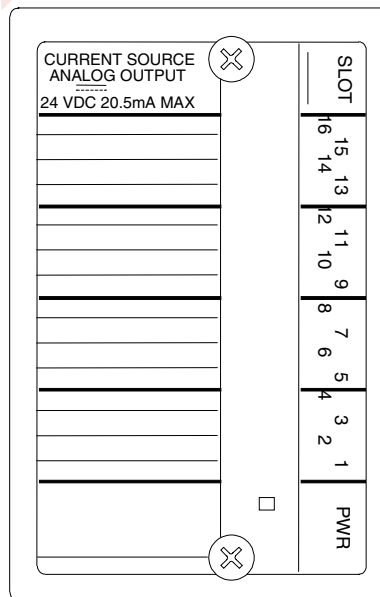

- Supports 8 channels of output currents ranging from 0 to 20 mA with 16-bit resolution.
- Output overrange provided for up to approximately 20.48mA.
- Uses both word and bit data types.
- Can be field-recalibrated or reset to factory calibration. Calibration data stored in FLASH memory.
- Individual channel configuration including default output level and scaling parameters.
- Reports Under/Overage, and Open Wire alarms.

Power Sources

The 8 Point Analog Current-source Output Module requires a separate source of power for the outputs.

LEDs

A single indicator shows module status:

- ON: normal operation
- Intermittent flashing: module fault
- OFF: No backplane power, no user power, or fatal fault.

Module Operation

During operation, the module receives engineering units output data from the Bus Interface Unit (BIU). It scales this data according to its calibration and configured scaling parameters, then converts the data to output current in the range of 0 mA to approximately 20.48 mA.

If the scaled data is below the minimum limit of the digital to analog converter, the module sets the output current to 0 mA. If the scaled data is above the maximum limit of the digital to analog converter, the module sets the output current to approximately 20.48 mA.

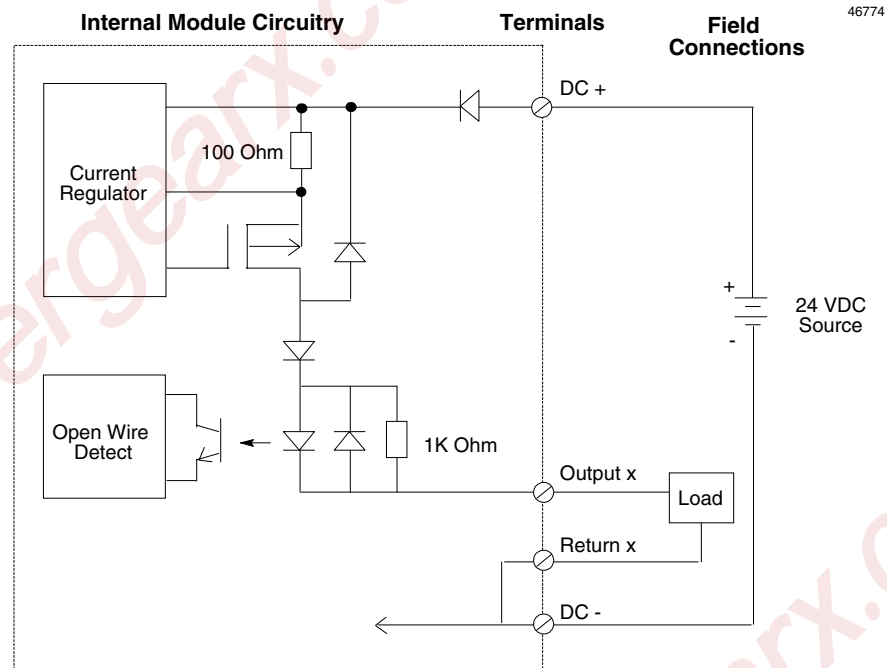

The 8 Point Analog Current-source Output Module provides the following alarms:

- **Over/Underrange:** indicates that an engineering units value sent by the host has resulted in an output value that is within approximately 30 microAmps of the module's maximum or minimum.
- **Open Wire:** The actual output value is below approximately 2mA. The Open Wire alarm is automatically enabled whenever the low span (output current) value is configured equal to or above 3.5mA.

If an alarm occurs, the module sets a bit in its optional discrete input data. These alarm bits can be monitored by the application logic. They can be reset by sending appropriate alarm-clearing discrete output data to the module.

8 Point Analog Current-Source Output Module**Host Interface**

The 8 Point Analog Current-source Output Module uses the following types of data:

- 0-8 words of analog output data
- 0-4 bytes of discrete input data for module and channel status.
- 0-2 bytes of discrete output data for clearing alarms.

The module exchanges data with a Bus Interface Unit in the same manner as other types of I/O modules-it provides all its input data and status bits when requested by the BIU, and receives fault-clearing commands and analog output data from the BIU.

The module can also be configured for “Group” data transfer with the BIU or with other intelligent devices in the same Field Control station. Group data transfer, and the steps for configuring it, are described in the *Bus Interface Unit User's Manual*.

Compatibility

This module must be used with a Bus Interface Unit revision 2.0 or later.

Group data transfer is only available with revision 1.1 or later.

Keying Locations

Optional keying locations for the 8 Point Analog Current-source Output Module are:

Keying Locations									
A	B	C	D	E	F	G	H	J	K
x		x						x	x

Module Configuration Overview

The 8 Point Analog Current-source Output Module is usually configured using a compatible hand-held programmer. The configuration can also be read or written from the bus in a system that supports such configuration. The table below summarizes configuration choices and defaults. The module will power up with the default configuration settings. For configuration instructions, refer to the *Bus Interface Unit User's Manual*.

Module Parameter	Description	Default	Choices
Analog Output Data Length	Length in words for the module's analog output data in the BIU's analog output (AQ) table.	8 words	0-8
Analog Output Reference	Starting offset for the module's analog output data in the BIU's analog output (AQ) table.		User selected
Discrete Input Data Length	Length in bits for the module's optional discrete input diagnostic data in the BIU's discrete input (I) table.	32 bits	0, 8, 16, 24, 32
Discrete Input Reference	Starting offset for the module's diagnostic data in the BIU's discrete input (I) table.		User selected
Discrete Output Data Length	Length in bits of the module's optional discrete output fault clearing data in the BIU's discrete output (Q) table.	16 bits	0, 8, 16
Discrete Output Reference	Starting offset for the module's fault clearing data in the BIU's discrete output (Q) table.		User selected
(BIU) Defaults: Input data	If the BIU loses communications with the module, the module's discrete input (diagnostic) data can be set to zero or hold its last state.	Zero	Zero, Hold Last State
(BIU) Defaults: Output data	If the BIU loses communications with the network, the module's discrete and analog output data can be set to zero or hold its last state.	Zero	Zero, Hold Last State
Local Defaults: Outputs	If a reset or local failure occurs, the module can set the actual outputs to zero or hold their last values (this requires local power).	Zero	Zero, Hold Last State
BIU Timeout	If the I/O scan is enabled and the module does not receive output data for this duration, the module defaults its outputs. Outputs remain defaulted until the module receives output data or power is cycled. The default output value is the Local Defaults setting. This parameter can only be changed by sending the module a configuration over the bus.	500mS	0 to 65535 mS
Channel Active	Determines whether a channel will respond to commanded analog output data and return alarms. If a channel is inactive its output is zero. If a previously-active channel is reconfigured as inactive, any pre-existing alarms can still be cleared using Q data.	Active	Inactive, Active
Range	There are three sets of default scaling parameters. (1) 4mA = 4000 (AQ), 20mA = 20000 (AQ) (2) 4mA = 0 (AQ), 20mA = 32000 (AQ) (3) 0mA = 0 (AQ) 20mA = 32000 (AQ) Any of these ranges can be edited by changing the parameters listed below. Custom scaling will result in a default range value of 0 (none).	1	1, 2, 3
Span Low	Actual current in microAmps to be scaled from low engineering units.	4000	0 to 20000
Span High	Actual current in microAmps to be scaled from high engineering units.	20000	0 to 20000
Engineering Low	Engineering units equivalent of the low span value.	4000	-32,768 to +32,767
Engineering High	Engineering units equivalent of the high span value.	20000	-32,768 to +32,767

Module Features

Channel Active

Each channel can be configured as either active or inactive.

If a channel is Inactive, its output is 0mA and the analog output data for the channel is not used. Alarm (optional discrete input) data for the channel is not updated for a channel that has been configured as Inactive.

If the configuration of a channel is changed from Active to Inactive, the module stops updating its alarm data. Pre-existing alarms can still be cleared using the module's configured discrete output bits.

Local Output Defaults

In addition to being able to configure data defaults of zero or hold last state for the module's data in the BIU, local output defaults for the module are also configurable. These module local defaults determine whether the module will set the actual output currents to zero milliAmps or hold their last values if a module error occurs.

Hold Last State

If the output default is Hold Last State and user power is present, the channel output holds its last value if:

1. The BIU resets the module.
2. No output data is received from the BIU within the BIU Timeout period.
3. Backplane power is lost.
4. The module's watchdog timer expires.

If either of the last two faults occurs, the default output resolution of the value is reduced from 16 bits to 14 bits.

Outputs will continue to hold their last states until the module receives output data from the BIU or until user power is removed.

Predefined Ranges and Custom Scaling

There are three predefined data scaling combinations, plus custom scaling.

Selection	Data Range (Engineering Units) = Output Current (μ A)
1	4000 to 20000 = 4000 to 20000 (default)
2	0 to 32000 = 4000 to 20000
3	0 to 32000 = 0 to 20000
none	Custom; scaled by user

During operation, the module converts engineering units into digital values that represent output current.

Scaling

Scaling defines the constant-slope mapping from the value in engineering units sent by the BIU to a channel's output current. The default scaling (selection 1) provides an output current range of 4mA (low span value) to 20mA (high span value) for engineering units values of 4,000 to 20,000. The illustration below represents the default scaling.

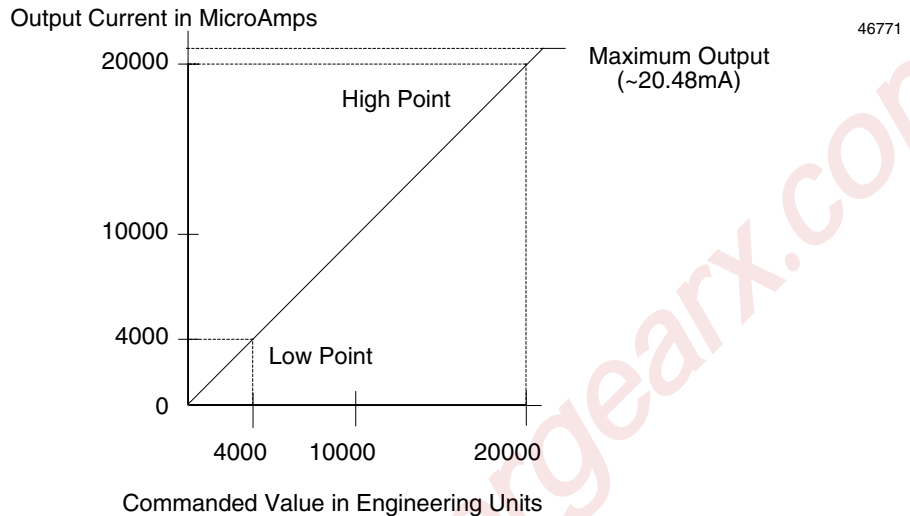

Scaling can be customized by changing any of the engineering units and/or output current values for each point. Span (output current) values are unsigned integers ranging from 0 to 20,000. Engineering units values are 16-bit signed integers from -32,768 to 32,767.

The scaling values selected do not restrict the hardware output range. For example, a channel with default scaling will output current below 4mA for engineering units values below 4,000.

It is possible to choose scaling parameters that actually do limit the current output. For example, associating a low engineering units value of -32,768 with a low span value of 2mA would assure that commanded values below that level would never be received by the module.

Module Specifications

Module Characteristics	
Number of channels (single ended)	8
Power supply range (see note 1)	18 to 30VDC, 24VDC typical. 10% maximum ripple
Operating temperature range	0 to 55 degrees C ambient
Isolation to ground and logic	1500 VAC for 1 minute, 250VAC continuous
Current Drawn from BIU power supply	85mA maximum
Current Drawn from external power supply	250 mA maximum (with all 8 outputs at 20mA)
Output Characteristics	
Resolution	16 bits
Magnitude data size	14 bits
Accuracy (see note 4): at 25deg. C from 0 to +55deg. C	0.05% typical, 0.1% maximum 0.15%
Output Current Range Limits: 0 to 20 (overrange)	0.0 to 20.48mA
Analog resolution	0.3125µA per count, maximum resolution
Output load capacitance	2000pF maximum
Output load inductance	0.5H maximum
User Load (dependent on temperature and power supply voltage. See notes 2 and 3)	0 to 1250 Ohms
Update time	1.5mS typical
Open wire output current threshold	1.0mA minimum, 3.5mA maximum

note 1: External power supply maximum voltage is dependent on temperature and user load.

note 2: Thermal (operating temperature) and user load derating curves apply. See below.

note 3: $(V_{\text{user}} - 5\text{VDC}) / 20 \text{ mA} = R_{L(\text{max})}$

note 4: In the presence of severe RF interference (IEC 801-3, 10V/m), accuracy may be degraded to $\pm 0.5\%$ tolerance.

Thermal Derating Curves

The chart below shows the minimum load in ohms at temperatures from 40 degrees to 55 degrees Celsius for user input power supply voltages of 18V, 24V, and 30V. If output load impedance is less than the minimum required, additional series resistance must be added.

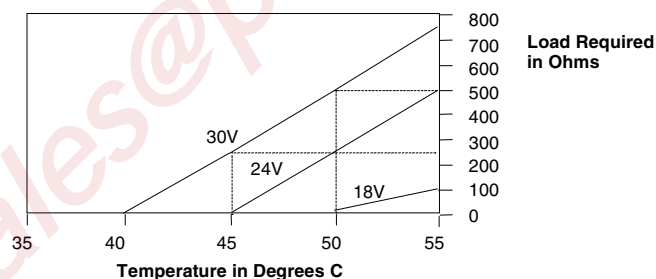

Field Wiring

Instrumentation grade Shielded Twisted Pair wire should be used for best noise immunity. The shield should be terminated at a local panel ground near the module. The following illustration shows typical connections for this module.

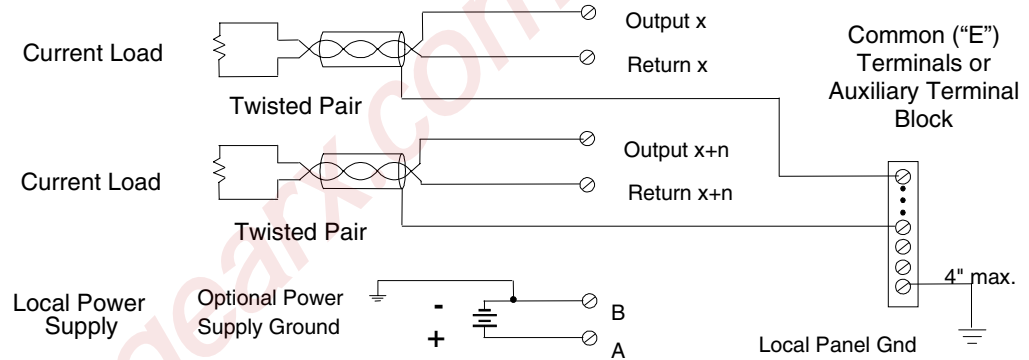

An Auxiliary Terminal Block can be used to provide additional wiring terminals for the shields. Auxiliary Terminal Blocks have all terminals connected together internally. The Auxiliary Terminal Block with box terminals (IC670TBM002) has 13 terminals; each accommodates one AWG #14 (avg 2.1mm² cross section) to AWG #22 (avg 0.36mm² cross section) wire. The Auxiliary Terminal Block with barrier terminals (IC670TBM001) has nine terminals; each can accommodate one or two wires up to AWG #14 (avg 2.1mm² cross section).

I/O Terminal Block Terminal Assignments

An Terminal Block with Box Terminals has 25 terminals per module. Each accommodates one AWG #14 (avg 2.1mm² cross section) to AWG #22 (avg 0.36mm² cross section) wire, or two wires up to AWG #18 (avg. 0.86mm² cross section). If an external jumper is used, single-wire capacity is reduced from AWG #14 (2.10mm²) to AWG #16 (1.32mm²). An I/O Terminal Block with Barrier Terminals has 18 terminals per module. Each terminal can accommodate one or two wires up to AWG #14 (avg 2.1mm² cross section). An I/O Terminal Block with Connectors has one 20-pin male connector per module.

All Return terminals are common to each other.

I/O Terminal Block with Box Terminals (IC670CHS002 and 102)	I/O Terminal Block with Barrier Terminals (IC670CHS001 and 101)	I/O Terminal Block with Wire to Board Connectors (IC670CHS003 and 103)																																																																																																																																				
<table border="0"> <tr><td>Return 8</td><td>16</td><td>15</td><td>Output 8</td></tr> <tr><td>Return 7</td><td>14</td><td>13</td><td>Output 7</td></tr> <tr><td>Common</td><td>E8</td><td></td><td></td></tr> <tr><td>Return 6</td><td>12</td><td>11</td><td>Output 6</td></tr> <tr><td>Return 5</td><td>10</td><td>9</td><td>Output 5</td></tr> <tr><td>Common</td><td>E6</td><td></td><td></td></tr> <tr><td>Return 4</td><td>8</td><td>7</td><td>Output 4</td></tr> <tr><td>Return 3</td><td>6</td><td>5</td><td>Output 3</td></tr> <tr><td>Common</td><td>E4</td><td></td><td></td></tr> <tr><td>Return 2</td><td>4</td><td>3</td><td>Output 2</td></tr> <tr><td>Return 1</td><td>2</td><td>1</td><td>Output 1</td></tr> <tr><td>Common</td><td>E2</td><td></td><td>Common</td></tr> <tr><td>DC-</td><td>B2</td><td>A2</td><td>DC+</td></tr> <tr><td>DC-</td><td>B1</td><td>A1</td><td>DC+</td></tr> </table> <p>Terminals E1, E2, E4, E6, and E8 are electrically connected together, A1 and A2 are electrically connected together, B1 and B2 are electrically connected together.</p>	Return 8	16	15	Output 8	Return 7	14	13	Output 7	Common	E8			Return 6	12	11	Output 6	Return 5	10	9	Output 5	Common	E6			Return 4	8	7	Output 4	Return 3	6	5	Output 3	Common	E4			Return 2	4	3	Output 2	Return 1	2	1	Output 1	Common	E2		Common	DC-	B2	A2	DC+	DC-	B1	A1	DC+	<table border="0"> <tr><td>Return 8</td><td>16</td><td>15</td><td>Output 8</td></tr> <tr><td>Return 7</td><td>14</td><td>13</td><td>Output 7</td></tr> <tr><td>Return 6</td><td>12</td><td>11</td><td>Output 6</td></tr> <tr><td>Return 5</td><td>10</td><td>9</td><td>Output 5</td></tr> <tr><td>Return 4</td><td>8</td><td>7</td><td>Output 4</td></tr> <tr><td>Return 3</td><td>6</td><td>5</td><td>Output 3</td></tr> <tr><td>Return 2</td><td>4</td><td>3</td><td>Output 2</td></tr> <tr><td>Return 1</td><td>2</td><td>1</td><td>Output 1</td></tr> <tr><td>DC-</td><td>B</td><td>A</td><td>DC+</td></tr> </table>	Return 8	16	15	Output 8	Return 7	14	13	Output 7	Return 6	12	11	Output 6	Return 5	10	9	Output 5	Return 4	8	7	Output 4	Return 3	6	5	Output 3	Return 2	4	3	Output 2	Return 1	2	1	Output 1	DC-	B	A	DC+	<table border="0"> <tr><td>Return 8</td><td>11</td><td>10</td><td>Return 5</td></tr> <tr><td>Output 8</td><td>12</td><td>9</td><td>Output 5</td></tr> <tr><td>Return 7</td><td>13</td><td>8</td><td>Return 4</td></tr> <tr><td>Output 7</td><td>14</td><td>7</td><td>Output 4</td></tr> <tr><td>Return 6</td><td>15</td><td>6</td><td>Return 3</td></tr> <tr><td>Output 6</td><td>16</td><td>5</td><td>Output 3</td></tr> <tr><td>DC+</td><td>A2</td><td>4</td><td>Return 2</td></tr> <tr><td>DC-</td><td>A1</td><td>3</td><td>Output 2</td></tr> <tr><td>DC-</td><td>B2</td><td>2</td><td>Return 1</td></tr> <tr><td>DC-</td><td>B1</td><td>1</td><td>Output 1</td></tr> </table>	Return 8	11	10	Return 5	Output 8	12	9	Output 5	Return 7	13	8	Return 4	Output 7	14	7	Output 4	Return 6	15	6	Return 3	Output 6	16	5	Output 3	DC+	A2	4	Return 2	DC-	A1	3	Output 2	DC-	B2	2	Return 1	DC-	B1	1	Output 1
Return 8	16	15	Output 8																																																																																																																																			
Return 7	14	13	Output 7																																																																																																																																			
Common	E8																																																																																																																																					
Return 6	12	11	Output 6																																																																																																																																			
Return 5	10	9	Output 5																																																																																																																																			
Common	E6																																																																																																																																					
Return 4	8	7	Output 4																																																																																																																																			
Return 3	6	5	Output 3																																																																																																																																			
Common	E4																																																																																																																																					
Return 2	4	3	Output 2																																																																																																																																			
Return 1	2	1	Output 1																																																																																																																																			
Common	E2		Common																																																																																																																																			
DC-	B2	A2	DC+																																																																																																																																			
DC-	B1	A1	DC+																																																																																																																																			
Return 8	16	15	Output 8																																																																																																																																			
Return 7	14	13	Output 7																																																																																																																																			
Return 6	12	11	Output 6																																																																																																																																			
Return 5	10	9	Output 5																																																																																																																																			
Return 4	8	7	Output 4																																																																																																																																			
Return 3	6	5	Output 3																																																																																																																																			
Return 2	4	3	Output 2																																																																																																																																			
Return 1	2	1	Output 1																																																																																																																																			
DC-	B	A	DC+																																																																																																																																			
Return 8	11	10	Return 5																																																																																																																																			
Output 8	12	9	Output 5																																																																																																																																			
Return 7	13	8	Return 4																																																																																																																																			
Output 7	14	7	Output 4																																																																																																																																			
Return 6	15	6	Return 3																																																																																																																																			
Output 6	16	5	Output 3																																																																																																																																			
DC+	A2	4	Return 2																																																																																																																																			
DC-	A1	3	Output 2																																																																																																																																			
DC-	B2	2	Return 1																																																																																																																																			
DC-	B1	1	Output 1																																																																																																																																			

Diagnostics Data

The 8 Point Analog Current-source Output Module performs diagnostics and provides 32 bits (4 bytes) of diagnostic data to the BIU. Data is placed in the BIU's discrete input (I) data table starting at the configured reference. The module sets the appropriate bit of this data when a diagnostic condition is detected. Diagnostics bits remain set until cleared by the appropriate data outputs, as described below. The condition causing the fault must be corrected, or the module will set the bit again.

Use of this data is optional. The module is easily configured to use all, some, or none of the diagnostic data.

Module Diagnostics Bits (byte 0)

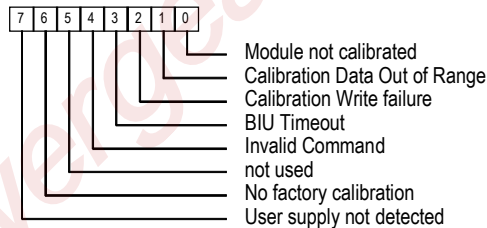

Channel Under/Overrange Bits (byte 2)

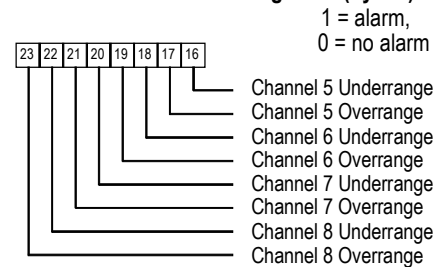

Channel Under/Overrange Bits (byte 1)

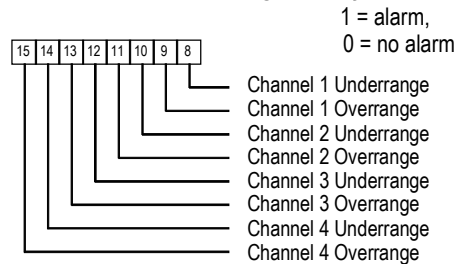

Channel Open Wire Bits (byte 3)

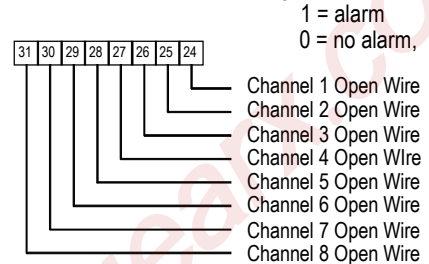

Clearing Faults and Alarms

The BIU uses two bytes of discrete output data to clear the module fault and alarm bits. The fault-clearing bits start at the module's configured discrete output reference in the BIU's discrete output (Q) table.

Setting a bit in the first byte of discrete output data to 1 clears the over/underrange and open wire alarms for the corresponding channel (even if the alarm conditions are still present).

The first two bits of the next byte can be used to clear module diagnostics (byte 0) bit #7 ("User supply not detected") and bit #3 ("BIU Timeout").

Bits #0-2, 4, and 6 in the module diagnostics byte are calibration-related and should never be set during normal operation. These bits cannot be cleared using discrete output (Q) data. If any of these bits is set during normal operation (not during calibration), a problem exists and the module should be returned.

Output Command Bits to Clear Alarms (byte 0)

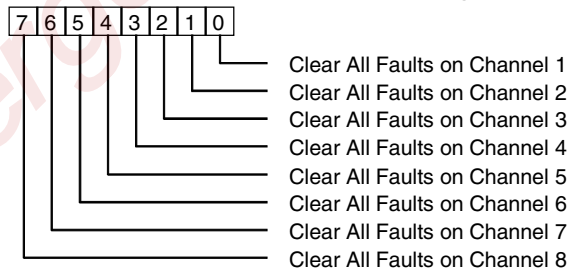

byte 1

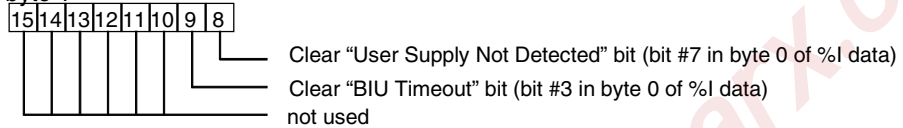

This appendix explains some general terms relating to measurements at analog I/O terminals.

Single-ended Single-ended circuits have the signal measured relative to a common connection, usually the power supply. Other analog I/O signals typically share this common. Single-ended circuits require fewest terminal points, giving the highest density and lowest price, but at the cost of more restrictive wiring and errors due to voltage drops and currents in the common connections. Single-ended circuit connections are most similar to the wiring of discrete modules.

Signal Common The term “signal common” refers to a point in the signal that may be connected to the corresponding points in other signal loops. It may or may not be connected to earth ground.

Differential Differential signals are measured on two wires which are separate, but not isolated from the power supply. Differential inputs allow a greater degree of freedom in wiring commons and grounds without affecting accuracy. There is a limited voltage rating (see Common Mode) between the signal level wires and the power supply wires. This limitation also applies to voltage differences among additional I/O on the same supply. Differential inputs usually come in groups sharing the supply common tie point. Some voltage outputs may have an “external return” or “remote sense” which allows the load common or ground to be different than the supply of the output module by a small voltage. “Current loop” signals are less susceptible to differences in voltage between circuit components. Differential inputs permit series inputs with current loops, since the signal can be offset from common. Do not confuse differential inputs with isolated inputs; differential requires the common tie point reference for all inputs of the group, usually either ground or the supply common.

Isolated Isolated inputs are usually two-wire and are dielectrically insulated from supplies and ground. Sometimes additional connections are provided for excitation of transducers such as RTDs, but these signals are not shared with other I/O points. Isolated modules allow high voltages to exist between I/O devices and the PLC. Do not confuse isolated inputs with the isolation between groups of analog circuits, or isolation from other components of the system, such as logic or power supplies.

- Normal Mode** This is the actual signal across the signal wires of differential or isolated I/O. This may also include unwanted noise such as power line frequency pickup.
- Common Mode** This is the voltage between the analog signal wires and the common point of the power supply of a differential signal, or to ground in the case of an isolated signal. It is desirable that all common mode signals are ignored by the circuit, but in practice there is some error introduced in the data. This is specified as Common Mode Rejection Ratio (CMRR), usually expressed in decibels (db). Differential circuits also have a maximum common mode voltage specifications, usually stated as a maximum voltage with respect to circuit common. Exceeding the common mode voltage rating of differential signals causes large errors in the data conversion and may affect several points.
- Unipolar** Unipolar signals or ranges do not change polarity during normal operation; for example 0 to 10 volts, or 4mA to 20mA. Reversed connection to a unipolar input will produce minimum value and, if diagnostics are available, underrange or open wire faults.
- Bipolar** Bipolar signals can reverse polarity in operation. Reversed signal connections to a bipolar input will produce data of opposite sign.
- Ground Loop** When a conductor is grounded in more than one place, differences between grounds can induce currents producing voltage drops in the wire. If the conductor is also used to carry an analog signal, these voltage drops produce an accuracy error or noisy values. If a single point ground is used, the voltage difference between locations may still appear in series with the desired signal. This is overcome by using differential or isolated inputs and running a separate return from the remote source. This preserves the integrity of the signal, and the ground voltages appear as common mode voltage at the receiving end.
- Current Loop** This is a standard analog interface defined by the Instrument Society of America in ANSI/ISA-S50-1. The signal level is 4mA to 20mA. Three types of signal sources are defined, Types 2, 3, and 4. These correspond to the number of wires used. The isolation of the transmitter may impact the type of PLC input required. When non-isolated inputs are used, isolation may be provided by means of a current transducer that has isolation between the current loop and/or power supply. The Standard covers only isolated or common (single-ended) inputs. Differential inputs often used in PLCs, and connecting several current loops together, as often occurs with PLCs, are not covered well in the Standard, and often introduce additional complication regarding location of commons and grounds.

This appendix explains how to select scaling values when configuring an analog input or output.

How Scaling Works

Analog modules convert between electrical signals (current or voltage) and digital values. These digital values are 0 to 4095 (for 12-bit converters). Digital values are often referred to as “counts”. They represent the data that is transferred between the Bus Interface Unit and an analog module.

To make the input or output data of conventional analog modules more meaningful to the application, the Bus Interface Unit performs a conversion process called scaling (note that the BIU performs scaling only for conventional analog modules; “intelligent” analog modules perform their own scaling). Scaling converts the module's digital values to or from the engineering units values used by the application.

Typically, the engineering units represent millivolts or microamps. In other cases, they represent physical units such as degrees or centimeters per second. Since engineering units values are integers from -32767 to +32767, it is often necessary to use fractional units (such as hundredths of degrees) to preserve the resolution of a physical input or output.

Each channel of an analog module can be scaled independently. Scaling is configured by entering corresponding low and high engineering units values and low and high internal values for two points. The internal values represent millivolts or microamps.

The BIU uses the straight line defined by the two pairs of values to convert between engineering units and analog convertor counts. The conversion takes into account the module type and the range that is selected.

Scaling Values for 1mV or 1 μ A Engineering Units: BIU Version 1.3

For many applications, the engineering units are either millivolts or microAmps. These units are easy to scale. Simply use the table below to find scaling values that are appropriate for the channel's configured range.

Analog Current Input Module

Range Selected	To measure this current	Enter this engineering units value		Internal Units (microAmps)	
4 to 20mA	4 mA	Low	4,000	Low	4,000
	20 mA	High	+20,000	High	+20,000
0 to 20 mA	0 mA	Low	0	Low	0
	20 mA	High	+20,000	High	+20,000

Analog Current Output Module

Range Selected	To output this current	Enter this engineering units value		Internal Units (microAmps)	
4 to 20mA	4 mA	Low	4,000	Low	0
	20 mA	High	+20,000	High	+20,000
0 to 20 mA*	0 mA	Low	0	Low	0
	20 mA	High	+20,000	High	+20,000

Analog Current Source Output Module (IC670ALG320) in Voltage Mode

Range Selected	To output this voltage	Enter this engineering units value		Internal Units (microAmps)	
4 to 20mA	0 volts	Low	0	Low	0
	+10 volts	High	+10,000	High	+20,000
0 to 20 mA*	0 volts	Low	0	Low	0
	+12.5 volts	High	+12,500	High	+20,000

* Connect the output load between Volt (V) and Return (RET) for the channel being used. For 0 to +12.5 voltage, place a jumper between RET and JMP on the terminal block.

Horner Analog Voltage Input Module (HE670ADC810)

Range Selected	To measure this voltage	Enter this engineering units value		Internal Units (microAmps)	
0 to 10 volts	0 volts	Low	0	Low	0
	+10 volts	High	+10,000	High	+10,000
-10 to +10 volts	-10 volts	Low	-10,000	Low	-10,000
	+10 volts	High	+10,000	High	+10,000

Scaling Values for 1mV or 1 μ A Engineering Units: BIU Version 2.0 or Later

For many applications, the engineering units are either millivolts or microAmps. These units are easy to scale. Simply use the table below to find scaling values that are appropriate for the channel's configured range.

Analog Current Input Module

Range Selected	To measure this current	Enter this engineering units value		Internal Units (microAmps)	
4 to 20mA	4 mA	Low	+4,000	Low	+4,000
	20 mA	High	+20,000	High	+20,000
0 to 20 mA	0 mA	Low	0	Low	0
	20 mA	High	+20,000	High	+20,000

Analog Current Output Module

Range Selected	To output this current	Enter this engineering units value		Internal Units (microAmps)	
4 to 20mA	4 mA	Low	+4000	Low	+4000
	20 mA	High	+20,000	High	+20,000
0 to 20 mA*	0 mA	Low	0	Low	0
	20 mA	High	+20,000	High	+20,000

Analog Current Source Output Module (IC670ALG320) in Voltage Mode

Range Selected	To output this voltage	Enter this engineering units value		Internal Units (microAmps)	
4 to 20mA	0 volts	Low	0	Low	+4000
	+10 volts	High	+10,000	High	+20,000
0 to 20 mA*	0 volts	Low	0	Low	0
	+12.5 volts	High	+12,500	High	+20,000

* Connect the output load between Volt (V) and Return (RET) for the channel being used. For 0 to +12.5 voltage, place a jumper between RET and JMP on the terminal block.

Horner Analog Voltage Input Module (HE670ADC810)

Range Selected	To measure this voltage	Enter this engineering units value		Internal Units (microAmps)	
0 to 10 volts	0 volts	Low	0	Low	0
	+10 volts	High	+10,000	High	+10,000
-10 to +10 volts	-10 volts	Low	-10,000	Low	-10,000
	+10 volts	High	+10,000	High	+10,000

Measuring Scaling Values

If the circuit will not use millivolt or microAmp units, the most accurate scaling values can be found by taking actual measurements of the process. The process must be set to two distinctly different conditions, so two sets of measurements can be taken.

If the analog module is already installed, you can use it online to the process being measured to obtain actual data values. By default, the Bus Interface Unit performs a 1 to 1 scaling on all channels. (Using the online method requires the prior configuration of at least the serial bus address, the I/O map, and the module I/O references).

Finding the Digital Value with the Module Online to the Process

If the module is online to the process, follow the steps below to find the scaling values.

1. Set the process to the first condition to be measured.
2. Using a suitable external device, find the engineering units measurement (for example, PSI, or degrees).
3. Read the corresponding value with the Hand-held Monitor or the programmer software. The units (using the default scaling) are millivolts or microAmps.
 - using a Hand-held Monitor in default mode, go to the Monitor screens and read the channel's digital value.
 - using the programmer software, go to the appropriate data table and read the channel's digital value.
4. Set the process to the second condition to be measured and repeat steps 2 and 3 to find the second pair of scaling values.

Finding the Digital Value without the Module Online

If the module is not online to the process, you will need to take two measurements from the process, and also measure the voltage or current associated with each. Convert this measurement to millivolts (for voltage) or microAmps (for current).

Example of Scaling an Analog Input

A channel is configured in the 0 to 10 volts DC range. It measures a velocity input. Electronic sensors and mechanical linkage external to the block have determined that an input level of +1.5 volts DC is equal to -20 feet/second (-6 meters/second), and that +9 volts DC is equal to +180 feet/second (+50 meters/second). Plotting these values on a graph shows that a signal of 5 volts DC corresponds to a speed of 73.3 feet/second.

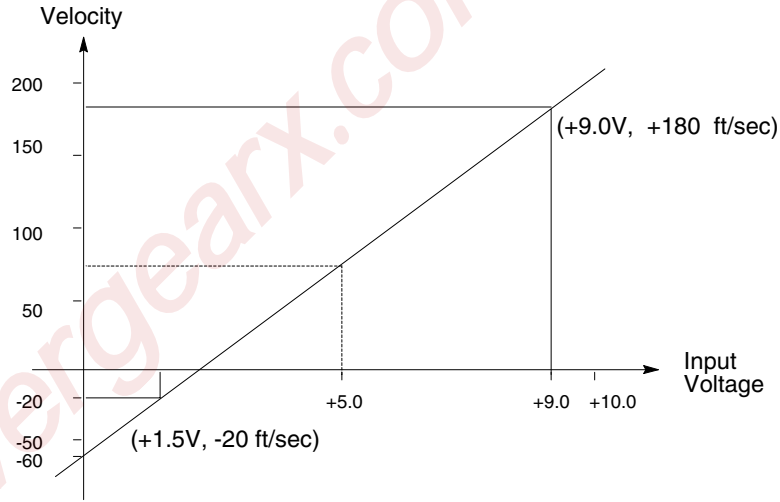

For engineering units of feet per second, the following scaling values are used:

Low engineering units	=	-20	ft/sec
High engineering units	=	+180	ft/sec
Low internal units	=	1500	millivolts
High internal units	=	9000	millivolts

An input value of 5.0 volts would be scaled to an engineering value of +00073 (ft/sec).

In this example, scaling to hundredths of feet per second would provide better resolution. The following scaling values would be used:

Low engineering units	=	-2000	hundredths ft/sec
High engineering units	=	+1800	hundredths ft/sec
Low internal units	=	1500	millivolts
High internal units	=	9000	millivolts

An input value of 5.0 volts would be scaled to an engineering value of +7333 (hundredths ft/sec).

sales@powergearx.com

sales@powergearx.com

sales@powergearx.com

A

Alignment tabs, 2-1, 2-17
Auxiliary I/O Terminal Blocks, 1-9
 installing, 2-1, 2-5
 removing, 2-1, 2-5

B

Bipolar analog signals, A-2

C

Cable between I/O Terminal Blocks, 2-1, 2-7
Cables
 between bases, 1-11
Connectors
 for cables between terminal blocks, 1-5, 2-1, 2-7
Current loop, A-2

D

Dimensions
 I/O modules, 1-2
DIN rail
 choosing and installing, 2-1, 2-2
 clamp, 2-1, 2-4
 mounting terminal block, 2-1, 2-4
 removing terminal block, 2-1, 2-4
 size and finish, 1-6
DIN rail latches, 1-5

F

Fuses
 spare fuse holder in terminal block, 1-5

G

Ground loop, A-2

H

Hot Insertion, 2-1, 2-17
Humidity, 1-3

I

I/O modules, 1-2
 installation, 2-1, 2-15
 keying, 1-3
 LEDs, 1-2
IC670ALG230, 18-1
IC670ALG240, 19-1

IC670ALG310, 22-1
IC670ALG320, 23-1
IC670ALG330, 24-1
IC670ALG620, 20-1
IC670ALG630, 21-1
IC670MDD441, 17-1
IC670MDL233, 3-1
IC670MDL240, 4-1
IC670MDL241, 5-1
IC670MDL330, 11-1
IC670MDL331, 12-1
IC670MDL640, 6-1
IC670MDL641, 7-1
IC670MDL642, 8-1
IC670MDL643, 9-1
IC670MDL644, 10-1
IC670MDL730, 13-1
IC670MDL740, 14-1
IC670MDL742, 15-1
IC670MDL930, 16-1
Installation
 I/O modules, 2-1, 2-15

K

Keying, 1-3
 assignments, 2-1, 2-15
 slots in terminal block, 1-5

L

Labels
 for box type terminals, 1-8
LEDs, 1-2

M

Mechanical contacts, installing in series with
 coil, 2-13
Module versions required for Hot Insertion, 2-
 1, 2-17

N

Noise, 1-3
 immunity, 2-1, 2-12

P

Power wiring, 2-1, 2-9

S

Scaling, B-1

Scaling values
 measuring, B-4
Specifications
 environmental, 1-3
 humidity, 1-3
 noise, 1-3
 temperature, 1-3
 vibration, 1-3
Suppression
 on discrete output load, 2-13

T

Temperature, 1-3
Terminal blocks, 1-4
 dimensions, 1-7
 DIN rail installation, 2-1, 2-4
 grounding screw, 1-5
 parts of, 1-5
 removing from DIN rail, 2-1, 2-4
 Thermocouple, 1-10
 types, 1-7
Terminal Blocks
 Auxiliary, 1-9
Terminals

V

Vibration, 1-3

W

Wiring, 1-7
 analog I/O, 2-1, 2-9
 discrete I/O, 2-1, 2-13
 for I/O modules, overview, 2-1, 2-9
 power, 2-1, 2-9