

## Specifications and Ordering Information

# 3300 Proximity Transducer System

Patents: 5,016,343; 5,126,664; 5,351,388; and 5,685,884

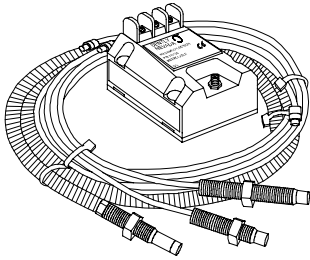

## Description

### Transducer System

The 3300 Proximity Transducer System consists of:

- a 3300 XL 8 mm probe or 3300 5 mm probe <sup>1,2</sup>
- a 3300 XL extension cable
- a 3300 Proximator<sup>®</sup> Sensor <sup>3, 4, 5</sup>

The system provides an output voltage directly proportional to the distance between the probe tip and the observed conductive surface. It is capable of both static (position) and dynamic (vibration) measurements, and is primarily used for vibration and position measurement applications on fluid-film bearing machines, as well as Keyphasor<sup>®</sup> and speed measurement applications <sup>6</sup>.

The system provides an accurate, stable signal output over a wide temperature range. All 3300 Proximity Transducer Systems achieve this level of performance while allowing complete interchangeability of probe, extension cable, and Proximator<sup>®</sup> Sensor without the need for individual component matching or bench calibration.

### Proximator<sup>®</sup> Sensor

The 3300 Proximator<sup>®</sup> Sensor offers many improvements over previous Bently Nevada eddy current transducers with better linearity and temperature stability. It also uses an integral isolation plate as its base, eliminating the need for separate isolator plates.

### Proximity Probes and Extension Cable

The 3300 XL 8 mm probe, 3300 5 mm probe, and 3300 XL extension cable also reflect improvements over previous designs. A patented TipLoc<sup>™</sup> molding method provides a more robust bond between the probe tip and the probe body. The probe's cable is more securely attached as well, incorporating a patented CableLoc<sup>™</sup> design that provides 330 N (75 lb) pull strength for 8 mm probe where the probe cable attaches to the probe tip.

Probes (8 mm only) and Extension Cables can also be ordered with an optional FluidLoc<sup>®</sup> cable option. This option prevents oil and other liquids from leaking out of the machine through the cable's interior.

### Connectors

The 3300 and 3300XL probes and extension cable have corrosion-resistant, gold-plated brass ClickLoc<sup>™</sup> connectors. These connectors require only finger-tight torque (connectors will "click"), and the specially engineered locking mechanism prevents the connectors from loosening. They do not require any special tools for installation or removal.

3300 Probes and Extension Cables can also be ordered with connector protectors already installed, or supplied separately for installation in the field (such as when the cable must be run through restrictive conduit). Connector protectors are recommended for all installations and provide increased environmental protection<sup>7</sup>.

**Notes:**

1. A 5 mm probe uses smaller physical packaging while providing the same linear range as an 8 mm probe; however, it does not permit reduced sideview clearances or tip-to-tip spacing requirements compared to an 8 mm probe. It is used when physical (not electrical) constraints preclude the use of an 8 mm probe, such as mounting between thrust bearing pads or other constrained spaces. When narrow sideview probes are required, consult your Bently Nevada Sales and Service Professional.
2. 8 mm probes provide a thicker encapsulation of the probe coil in the molded PPS plastic probe tip. This results in a more rugged probe. The larger diameter of the probe body also provides a stronger, more robust case. Bently Nevada recommends the use of 8 mm probes when possible to provide optimal robustness against physical abuse.
3. A 3300 XL Proximitor Sensor is available and provides numerous improvements over the non-XL version. It is electrically and mechanically interchangeable with the non-XL version, and is recommended as best available technology for most applications. Although the packaging of the 3300 XL Proximitor sensor differs from its predecessor, it is designed to fit in the same 4-hole mounting pattern when used with the 4-hole mounting base, and will fit within the same mounting space specifications (when minimum permissible cable bend radius is observed). Consult Specifications and Ordering Information (p/n 141194-01) or our Bently Nevada Sales and Service Professional for more information.
4. When XL and non-XL components are mixed, system performance is limited to the specifications for the non-XL 3300 system.
5. Proximitor<sup>®</sup> Sensors are supplied by default from the factory calibrated to AISI 4140 steel. Calibration to other target materials is available upon request.
6. Consult Bently Nevada Applications Note AN085 when considering this transducer system for tachometer or overspeed measurements.
7. Silicone tape is also provided with each 3300 XL extension cable and can be used instead of connector protectors. Silicone tape is not recommended in applications where the probe-to-extension cable connection will be exposed to turbine oil.

## Specifications

Unless otherwise noted, the following specifications are for a proximity transducer system between 18°C and 27°C (64°F to 80°F) with a -24 Vdc power supply, a 10 k Ω load, an AISI 4140 steel target, and a probe gapped at 1.27 mm (50 mils).

### Electrical

*Proximitor<sup>®</sup> Sensor Input:* Accepts one noncontacting 3300 5 mm, 3300 8 mm or 3300 XL 8 mm Proximity Probe and Extension Cable.

*Power:* Requires -17.5 Vdc to -26 Vdc at 12 mA maximum consumption. Operation at a more positive voltage than -23.5 Vdc can result in reduced linear range.

*Supply Sensitivity:* Less than 2 mV change in output voltage per volt change in input voltage.

*Output resistance:* 50 Ω

<i>Probe dc resistance (R<sub>PROBE</sub>)</i>	
Probe Length (m)	Resistance from the Center Conductor to the Outer Conductor (Ω)
0.5	7.45 ± 0.50
1.0	7.59 ± 0.50
1.5	7.73 ± 0.50
2.0	7.88 ± 0.50
5.0	8.73 ± 0.70
9.0	9.87 ± 0.90

<i>Extension cable dc resistance</i>		
Length of Extension Cable	Resistance from Center Conductor to Center Conductor (R <sub>CORE</sub> ) (Ω)	Resistance from Outer Conductor to Outer Conductor (R <sub>JACKET</sub> ) (Ω)
3.0	0.66 ± 0.10	0.20 ± 0.04
3.5	0.77 ± 0.12	0.23 ± 0.05
4.0	0.88 ± 0.13	0.26 ± 0.05
4.5	0.99 ± 0.15	0.30 ± 0.06
7.0	1.54 ± 0.23	0.46 ± 0.09
7.5	1.65 ± 0.25	0.49 ± 0.10
8.0	1.76 ± 0.26	0.53 ± 0.11
8.5	1.87 ± 0.28	0.56 ± 0.11

**Note:** Outer conductor refers to the shielded conductor which is attached to the connector, not the armor braid.

*Extension cable capacitance:* 69.9 pF/m (21.3 pF/ft) typical.

*Field Wiring Length:* Recommend using three-conductor shielded triad cable. 305 metres (1,000 feet) maximum length between 3300 Proximity Transducer and monitor. Consult Performance Specification 155687 for signal rolloff at high frequencies when using longer field wiring lengths or external safety barriers located some distance from the monitoring system.

*Linear Range:* 2 mm (80 mils). Linear range begins at approximately 0.25 mm (10 mils) from target and is from 0.25 to 2.3 mm (10 to 90 mils).

*Recommended Gap Setting:* 1.27 mm (50 mils).

*Incremental Scale Factor:* 7.87 mV/ $\mu$ m (200 mV/mil)  $\pm$ 6.5% typical, including interchangeability error when measured in increments of 0.25 mm (10 mils) over the linear range.

*Deviation from best fit straight line (DSL):* Less than  $\pm$ 38  $\mu$ m ( $\pm$ 1.5 mil) typical deviation from best fit straight line.

*Probe Temperature Stability (typical):* Over probe temperature range of -35°C to +177°C (-31°F to +350°F), the incremental scale factor remains within  $\pm$ 10% of 7.87 mV/ $\mu$ m (200 mV/mil) and the deviation from the best fit straight line remains within  $\pm$ 276  $\mu$ m ( $\pm$ 3 mils).

*Frequency Response:* 0 to 6.5 kHz: +0, -3 dB, with up to 305 metres (1000 feet) of field wiring.

*Minimum Target Size:* 15.2 mm (0.6 in) diameter (flat target).

#### *Shaft Diameter*

*Minimum:* 50.8 mm (2 in)

*Recommended minimum:* 76.2 mm (3 in)

Measurements on shaft diameters smaller than 50 mm (2 in) usually require close spacing of radial vibration or axial position transducers with the potential for their electromagnetic emitted fields to interact with one another (cross-talk), resulting in erroneous readings. Care should be taken to maintain minimum separation of transducer tips, generally at least 40 mm (1.6 in) for axial position measurements or 74 mm (2.9 in) for radial vibration measurements. Radial vibration or position measurements on shaft diameters smaller than 76.2 mm (3 in) will generally result in a change in scale factor. Consult Performance Specification 155687 for additional information.

*Electrical Certification:* Complies with the European CE mark.

---

#### **Hazardous Area Approvals**

*CSA/NRTL/C:* Exia for Class I, Division 1, Groups A, B, C, and D, when installed with intrinsically safe zener barriers per drawing CA22000, or galvanic isolators. Class I, Division 2, Groups A, B, C, and D without barriers.  
T4A @ Ta=100°C; T5 @ Ta=65°C

*BASEEFA / CENELEC:* EExia for Zones 0, 1, and 2, Groups I, IIA, IIB, & IIC, BASEEFA certificate number Ex90C2300X, when installed with intrinsically safe zener barriers or galvanic isolators. ExN for Zone 2, Groups IIA, IIB, and IIC, BASEEFA certificate number Ex90Y4301U. T4 @ Ta=100°C

---

#### **Mechanical**

*Probe Tip Material:* Polyphenylene sulfide (PPS).

*Probe Case Material:* AISI 304 stainless steel (SST).

*Probe Cable:* 0.5, 1, 2, 5, or 9 m lengths for 5 mm probes; 0.5, 1, 1.5, 2, 5, or 9 m lengths for 8 mm probes.

*Proximito<sup>®</sup> Sensor Material:* A383 aluminum.

*System Length:* 5 or 9 metres including extension cable.

*Extension Cable:* 75  $\Omega$  triaxial, fluoroethylene propylene (FEP) insulated.

*Extension Cable Armor (optional):* Flexible AISI 302 SST with FEP outer jacket.

#### *Tensile Strength*

*8 mm probes:* 330 N (75 lb) probe case to probe lead. 270 N (60 lb) probe lead to extension cable connectors.

*5 mm probes:* 220 N (50 lb) probe case to probe lead. 220 N (50 lb) probe lead to extension cable connectors.

*Connector Material:* Gold-plated brass.

*Total System Weight:* 0.59 kg (1.3 lb) typical.

Probe case torque		
	Maximum Rated	Recommended
M10X1 or 3/8-24 forward-mount probes	33.9 N•m (300 in•lb)	11.2 N•m (100 in•ft)
M10X1 or 3/8-24 forward-mount probes, first three threads	22.6 N•m (200 in•lb)	7.5 N•m (66 in•lb)
M8X1 or 1/4-28 forward mount probes	7.3 N•m (65 in•lb)	5.1 N•m (45 in•lb)
Reverse mount probes	22.6 N•m (200 in•lb)	7.5 N•m (66 in•lb)

#### Connector-to-connector torque

*Recommended torque:* See table below.

*Maximum torque:* 0.565 N•m (5 in•ft)

Connector Type	Tightening Instructions
Two 3300 XL gold "click" type connectors	Finger tight
One non-XL stainless steel connector and one 3300 XL connector	Finger tight plus 1/8 turn using pliers

*Minimum Cable Bend Radius:* 25.4 mm (1.0 in).

*Total System Weight:* 0.71 kg (1.6 lb), typical.

*Probe:* 323 g (11.38 oz).

*Extension Cable:* 34 g/m (1.5 oz/lb).

*Armored Extension Cable:* 103 g/m (1.5 oz/ft).

*Proximator® Sensor:* 255 g (9.0 oz).

#### Environmental Limits

*Probe Temperature Range:* -51°C to +177°C (-60°F to +351°F) for 3300 XL probes;  
-35°C to +177° (-31°F to +351°F) for non-XL probes.

**Note:** Exposing the probe to temperatures below -34°C (-30°F) may cause premature failure of the pressure seal.

*Extension Cable Temperature Range:* -51°C to +177°C (-60°F to +351°F)

#### Proximator® Sensor Temperature Range

*Operating Temperature:* -51°C to +100°C (-60°F to +212°F)

*Storage Temperature:* -51°C to +100°C (-60°F to +212°F)

*Relative Humidity:* 100% condensing, non-submersible when connectors are protected.

*Probe Pressure:* 3300 5 mm and 3300 XL 8 mm probes are designed to seal differential pressure between the probe tip and case. The probe sealing material consists of a Viton® O-ring. Probes are not pressure-tested prior to shipment. Contact our custom design department if you require a test of the pressure seal for your application.

**Note:** It is the responsibility of the customer or user to ensure that all liquids and gases are contained and safely controlled should leakage occur from a proximity probe. In addition, solutions with high or low pH values may erode the tip assembly of the probe causing media leakage into surrounding areas. Bently Nevada Corporation will not be held responsible for any damages resulting from leaking proximity probes. In addition, 3300 5 mm and 3300 XL 8 mm proximity probes will not be replaced under the service plan due to probe leakage.

Effects of 60 Hz Magnetic Fields Up to 420 Gauss (5 metre system):			
Output voltage in mil pp/gauss:			
Gap	Proximator® Sensor	Probe	Ext. Cable
10 mil	0.0015	0.0004	0.0004
50 mil	0.0048	0.0014	0.0014
90 mil	0.0108	0.0045	0.0045

**Patents:** 5,016,343; 5,126,664; 5,351,388; and 5,685,884. Components or procedures described in the patents apply to this product

## Ordering Information

### 3300 XL 8 mm Proximity Probes

330101 3300 XL 8 mm Probe, 3/8-24 UNF thread, without armor

330102 3300 XL 8 mm Probe, 3/8-24 UNF thread, with armor

#### Part Number-AXX-BXX-CXX-DXX-EXX

##### Option Descriptions

*A: Unthreaded Length Option* **Note:** Unthreaded length must be at least 0.8 in less than the case length. Order in increments of 0.1 in  
**Length configurations:**  
Maximum unthreaded length: 8.8 in = **8 8**.  
Minimum unthreaded length: 0.0 in = **0 0**.  
**Example: 0 4 = 0.4 in**

*B: Overall Case Length Option* Order in increments of 0.1 in  
**Threaded length configurations:**  
Maximum case length: 9.6 in = **9 6**.  
Minimum case length: 0.8 in = **0 8**.  
**Example: 2 4 = 2.4 in**

*C: Total Length Option* **0 5** 0.5 metre (1.6 feet)  
**1 0** 1.0 metre (3.3 feet)  
**1 5** 1.5 metre (4.9 feet)  
**2 0** 2.0 metres (6.6 feet)  
**5 0** 5.0 metres (16.4 feet)  
**9 0** 9.0 metres (29.5 feet)

*D: Connector Option* **0 0** Connector not installed, standard cable  
**0 1** Miniature coaxial ClickLoc™ connector with connector protector, standard cable  
**0 2** Miniature coaxial ClickLoc™ connector, standard cable  
**1 0** Connector not installed, FluidLoc® cable  
**1 1** Miniature coaxial ClickLoc™ connector with connector protector, FluidLoc® cable  
**1 2** Miniature coaxial ClickLoc™ connector, FluidLoc® cable.

*E: Agency Approval Option* **0 0** Not required  
**0 5** Multiple Approvals

### 3300 5 mm Proximity Probes

330171 3300 5 mm Probe, 1/4-28 UNF thread, without armor

330172 3300 5 mm Probe, 1/4-28 UNF thread, with armor

#### Part Number-AXX-BXX-CXX-DXX-EXX

##### Option Descriptions

*A: Unthreaded Length Option* **Note:** Unthreaded length must be at least 0.8 in less than the case length. Order in increments of 0.2 in  
**Length configurations:**  
Maximum unthreaded length: 8.8 in = **8 8**.  
Minimum unthreaded length: 0.0 in = **0 0**.  
**Example: 0 4 = 0.4 in**

*B: Overall Case Length Option* Order in increments of 0.1 in  
**Threaded length configurations:**  
Maximum case length: 9.6 in = **9 6**.  
Minimum case length: 0.8 in = **0 8**.  
**Example: 2 4 = 2.4 in**

*C: Total Length Option* **0 5** 0.5 metre (1.6 feet)  
**1 0** 1.0 metre (3.3 feet)  
**2 0** 2.0 metres (6.6 feet)  
**5 0** 5.0 metres (16.4 feet)  
**9 0** 9.0 metres (29.5 feet)

*D: Connector Option* **0 0** No connector supplied, standard cable  
**0 1** Miniature coaxial ClickLoc™ connector with connector protector, standard cable  
**0 2** Miniature coaxial ClickLoc™ connector, standard cable

*E: Agency Approval Option* **0 0** Not required  
**0 5** Multiple Approvals

### 3300 XL 8 mm Proximity Probes, Metric

330103 3300 XL 8 mm Probe, M10 x 1 thread, without armor

330104 3300 XL 8 mm Probe, M10 x 1 thread, with armor

#### Part Number-AXX-BXX-CXX-DXX-EXX

##### Option Descriptions

*A: Unthreaded Length Option* **Note:** Unthreaded length must be at least 20 mm less than the case length.

Order in increments of 10 mm.  
**Length configuration:**  
Maximum unthreaded length: 230 mm = **2 3**.

Minimum unthreaded length: 0.0 mm = **0 0**.  
**Example: 0 6** = 60 mm.

*B: Overall Case Length Option*

Order in increments of 10 mm.  
**Metric thread configurations:**  
 Maximum length: 250 mm  
 Minimum length: 20 mm  
**Examples: 0 6** = 60 mm

*C: Total Length Option*

**0 5** 0.5 metre (1.6 feet)  
**1 0** 1.0 metre (3.3 feet)  
**1 5** 1.5 metres (4.9 feet)  
**2 0** 2.0 metres (6.6 feet)  
**5 0** 5.0 metres (16.4 feet)  
**9 0** 9.0 metres (29.5 feet)

*D: Connector Option*

**0 0** Connector not installed, standard cable  
**0 1** Miniature coaxial ClickLoc™ connector with connector protector, standard cable  
**0 2** Miniature coaxial ClickLoc™ connector, standard cable  
**1 0** Connector not installed, FluidLoc® cable  
**1 1** Miniature coaxial ClickLoc™ connector with connector protector, FluidLoc® cable  
**1 2** Miniature coaxial ClickLoc™ connector, FluidLoc® cable

*E: Agency Approval Option*

**0 0** Not required  
**0 5** Multiple Approvals

**3300 5 mm Proximity Probes, Metric**

**330173** 3300 5 mm Probe, M8 x 1 thread, without armor  
**330174** 3300 5 mm Probe, M8 x 1 thread, with armor

**Part Number-AXX-BXX-CXX-DXX-EXX**  
**Option Descriptions**

*A: Unthreaded Length Option*

**Note:** Unthreaded length must be at least 20 mm less than the case length.

Order in increments of 10 mm.  
**Length configuration:**  
 Maximum unthreaded length: 230 mm = **2 3**.  
 Minimum unthreaded length: 0.0 mm = **0 0**.  
**Example: 0 6** = 60 mm.

*B: Overall Case Length Option*

Order in increments of 10 mm.  
**Metric thread configurations:**  
 Maximum length: 250 mm = **2 5**.  
 Minimum length: 20 mm = **0 2**.  
**Examples: 0 6** = 60 mm.

*C: Total Length Option*

**0 5** 0.5 metre (1.6 feet)  
**1 0** 1.0 metre (3.3 feet)  
**2 0** 2.0 metres (6.6 feet)  
**5 0** 5.0 metres (16.4 feet)  
**9 0** 9.0 metres (29.5 feet)

*D: Connector Option*

**0 0** No connector supplied, standard cables  
**0 1** Miniature coaxial ClickLoc™ connector with connector protector, standard cable  
**0 2** Miniature coaxial ClickLoc™ connector, standard cable

*E: Agency Approval Option*

**0 0** Not required  
**0 5** Multiple Approvals

**3300 XL 8 mm Reverse Mount probe, 3/8-24 UNF threads**  
**330105-A02-B12-CXX-DXX-EXX**

**3300 XL 8 mm Reverse Mount probe, M10 x 1 threads**  
**330106-A05-B30-CXX-DXX-EXX**

**Option Descriptions**

*C: Total Length Option*

**0 5** 0.5 metre (1.6 feet)  
**1 0** 1.0 metre (3.3 feet)  
**1 5** 1.5 metres (4.9 feet)  
**2 0** 2.0 metres (6.6 feet)  
**5 0** 5.0 metres (16.4 feet)  
**9 0** 9.0 metres (29.5 feet)

*D: Connector Option*

**0 0** Connector not installed, standard cable  
**0 2** Miniature ClickLoc™ coaxial connector, standard cable

*E: Agency Approval Option*

**0 0** Not required  
**0 5** Multiple Approvals

**3300 XL 8 mm Proximity Probes, Smooth Case**

**330140** 3300 XL 8 mm Probe without armor  
**330141** 3300 XL 8 mm Probe with armor

**Part Number-AXX-BXX-CXX-DXX**  
**Option Descriptions**

*A: Overall Case Length Option*

Order in increments of 0.1 in  
**Threaded length configurations:**  
 Maximum length: 9.6 in = **9 6**.  
 Minimum length: 0.8 in = **0 8**.  
**Example: 2 4** = 2.4 in

<i>B: Total Length Option</i>	<b>0 5</b>	0.5 metre (1.6 feet)
	<b>1 0</b>	1.0 metre (3.3 feet)
	<b>1 5</b>	1.5 metre (4.9 feet)
	<b>2 0</b>	2.0 metres (6.6 feet)
	<b>5 0</b>	5.0 metres (16.4 feet)
	<b>9 0</b>	9.0 metres (29.5 feet)

<i>C: Connector Option</i>	<b>0 0</b>	Connector not installed, standard cable
	<b>0 1</b>	Miniature coaxial ClickLoc™ connector with connector protector, standard cable
	<b>0 2</b>	Miniature coaxial ClickLoc™ connector, standard cable
	<b>1 0</b>	Connector not installed, FluidLoc® cable
	<b>1 1</b>	Miniature coaxial ClickLoc™ connector with connector protector, FluidLoc® cable
	<b>1 2</b>	Miniature coaxial ClickLoc™ connector, FluidLoc® cable

<i>D: Agency Approval Option</i>	<b>0 0</b>	Not required
	<b>0 5</b>	Multiple Approvals

**Notes:**

1. Mounting clamps must be ordered separately for 330140 and 330141.
2. For a shorter delivery time, order commonly stocked probes. Currently, stocked probes consist of the following part numbers: 330101-00-08-05-02-00, 330101-00-08-10-02-00, 330101-00-12-10-02-00, 330101-00-12-10-02-05, 330101-00-20-05-02-00, 330101-00-20-10-02-00, 330101-00-20-10-02-05, 330101-00-30-10-02-00, 330101-00-40-10-02-00, 330103-00-02-10-02-05, 330103-00-04-10-02-00, 330105-02-12-05-02-00, 330105-02-12-05-02-05, 330105-02-12-10-02-00, 330105-02-12-10-02-05, 330106-05-30-05-02-00, 330106-05-30-05-02-05, 330106-05-30-10-02-00, 330106-05-30-10-02-05, 330171-00-08-05-02-00, 330171-00-08-10-02-00, 330171-00-20-10-02-00, and 330171-00-40-10-02-00.

**3300 Proximito<sup>®</sup> Sensor  
330100-AXX-BXX  
Option Descriptions**

<i>A: Total Length Option</i>	<b>5 0</b>	5.0 metres (16.4 feet)
	<b>9 0</b>	9.0 metres (29.5 feet)

<i>B: Agency Approval Option</i>	<b>0 0</b>	Not required
	<b>0 5</b>	Multiple Approvals

**3300 XL Extension Cable  
330130-AXXX-BXX-CXX**

Make sure that the extension cable length and the probe length, when added together, equal the Proximito<sup>®</sup> Sensor total length.

**Option Descriptions**

<i>A: Cable Length Option</i>	<b>0 3 0</b>	3.0 metres (9.8 feet)
	<b>0 3 5</b>	3.5 metres (11.5 feet)
	<b>0 4 0</b>	4.0 metres (13.1 feet)

<b>0 4 5</b>	4.5 metres (14.8 feet)
<b>0 7 0</b>	7.0 metres (22.9 feet)
<b>0 7 5</b>	7.5 metres (24.6 feet)
<b>0 8 0</b>	8.0 metres (26.2 feet)
<b>0 8 5</b>	8.5 metres (27.9 feet)

*B: Connector and Cable Option*

<b>0 0</b>	Standard cable
<b>0 1</b>	Armored cable
<b>0 2</b>	Standard cable with connector protectors
<b>0 3</b>	Armored cable with connector protectors
<b>1 0</b>	FluidLoc® cable
<b>1 1</b>	Armored FluidLoc® cable
<b>1 2</b>	FluidLoc® cable with connector protectors
<b>1 3</b>	Armored FluidLoc® cable with connector protectors

*C: Agency Approval Option*

<b>0 0</b>	Not required
<b>0 5</b>	Multiple Approvals

**Accessories**

**86130-01** Manual

**155687** Performance Specification

**Field Wiring Cable  
132501-AXX**

1.0 mm<sup>2</sup> (18 AWG), 3-conductor, twisted, shielded cable for connections between Proximito<sup>®</sup> Sensor and monitor. Terminal ring lugs are installed at each end including an extra shield ring lug at the monitor end.

*A: Cable length option in feet.*

Order in increments of 1.0 foot (0.3 metres)

**Minimum length:** 2 feet (0.6 metres) = 0 2

**Maximum length:** 99 feet (30 metres) = 9 9

**Examples:**

**1 5** = 15 feet (4.6 metres)

**2 0** = 20 feet (6.1 metres)

**02120015**  
Bulk field wire

1.0 mm<sup>2</sup> (18 AWG), 3-conductor, twisted, shielded cable with drain wire. Specify length in feet.

**02173009**  
Bulk field wire

1.0 mm<sup>2</sup> (18 AWG), 3-conductor, twisted, shielded cable. Specify length in feet.

**Aluminum probe clamp bracket**  
**137491-AXX**  
**Option Descriptions**

- A: Thread size*
- 0 1** 10-24 UNC-2A mounting screws
  - 0 2** M5 x 0.8-6g Mounting screws  
 The aluminum clamp bracket is an unthreaded mounting bracket designed for use with the smooth case probes (330140 and 330141). After gapping the probe, tighten the clamp bracket by tightening the screws. The mounting screws have pre-drilled holes for safety wire.

**Aluminum probe mounting bracket**  
**137492 -AXX**  
**Option Descriptions**

- A: Thread size*
- 0 1** 3/8-24
  - 0 2** 1/4-28
  - 0 3** M8 x 1
  - 0 4** M10 x 1
- The aluminum probe mounting bracket is the standard mounting bracket for most 3300 and 3300 XL probe installations. The -01 and -02 options are supplied with two 10-24 UNC-2A mounting screws. The -03 and -04 options are supplied with two M5 x 0.8-6g mounting screws. The mounting screws have pre-drilled holes for safety wire.

**Phenolic probe mounting bracket**  
**27474 -AXX**  
**Option Descriptions**

- A: Thread size*
- 0 1** 3/8-24
  - 0 2** 1/4-28
  - 0 3** M8 x 1
  - 0 4** M10 x 1
- The phenolic mounting bracket is recommended if additional electric isolation from the mounting location is required (as in some generator and electrical motor bearing locations). The -01 and -02 options are supplied with two 10-24 UNC-2A mounting screws. The -03 and -04 options are supplied with two M5 x 0.8-6g mounting screws. The mounting screws have pre-drilled holes for safety wire.

**330951-01**  
**Proximator® Sensor**  
**Mounting Screws**

Package includes 4 mounting screws. (Not needed if Bently Nevada Proximator® Housings are used.)

**03200006**  
**Silicone self-fusing**  
**tape**

9.1 metre (10 yard) roll of silicone tape to protect connectors. It is easy to install and provides excellent electrical isolation and protection from the environment. It is not recommended for use inside the casing of the machine.

**40113-02**  
**Connector Protector**  
**Kit**

Connector Protector Kit for 3300 XL 8 mm probes and extension cables, including connector protectors and installation tools.

**136536-01**  
**Connector Protector**  
**Adapter**

Makes our previous 3300 connector protector kits compatible with 3300 XL extension cable connectors.

**40180-02**  
**Connector Protectors**

Package containing 10 pairs of connector protectors.

**03839410**  
**Male Connector**  
**Protector**

Placed onto the extension cable to connect to the female connector protector on 8 mm probes and provide environmental protection of connectors.

**03839420**  
**Female Connector**  
**Protector**

Placed onto 8 mm probe leads to connect to the male connector protector on the extension cable and provide environmental protection of connectors. Also placed onto the extension cable to slide over the Proximator® Sensor connection and protect it from the environment.

**04301007**  
**3/8-24 Probe Lock**  
**Nut with safety wire**  
**holes**

Single probe lock-nut with two holes drilled through the nut in order to secure the lock-nut in place with safety wire.

**04301008**  
**M10 x 1 Probe Lock**  
**Nut with safety wire**  
**holes**

Single probe lock-nut with two holes drilled through the nut in order to secure the lock-nut in place with safety wire.



**330152-01**  
3300 XL Connector  
Kit

Used on 3300 XL 8 mm probes,  
3300 5 mm probes, and 3300 XL  
extension cables. Contains one set  
of male and female ClickLoc™  
connectors, sleeves, and one strip  
of silicone tape.

**136540-01**  
Connector Crimp  
Tool Kit

Includes one set of 75 Ω 3300 XL  
ClickLoc™ inserts and connector  
installation instructions.

© 2000 Bently Nevada Corporation

© used in this document are registered marks of Bently Nevada Corporation  
Viton® is a registered trademark of DuPont Dow Elastomers L.L.C.

# Graphs

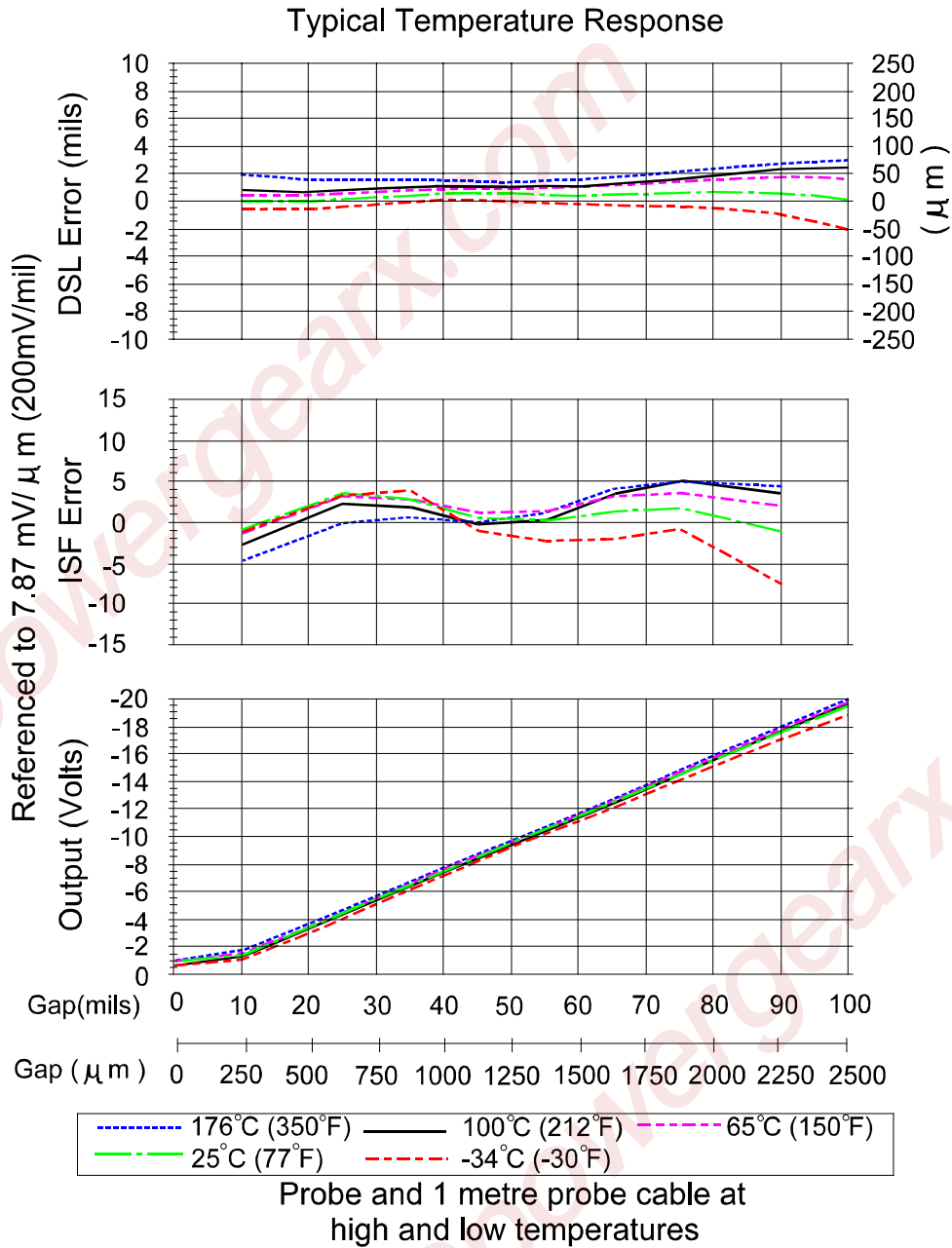

### Typical Temperature Response

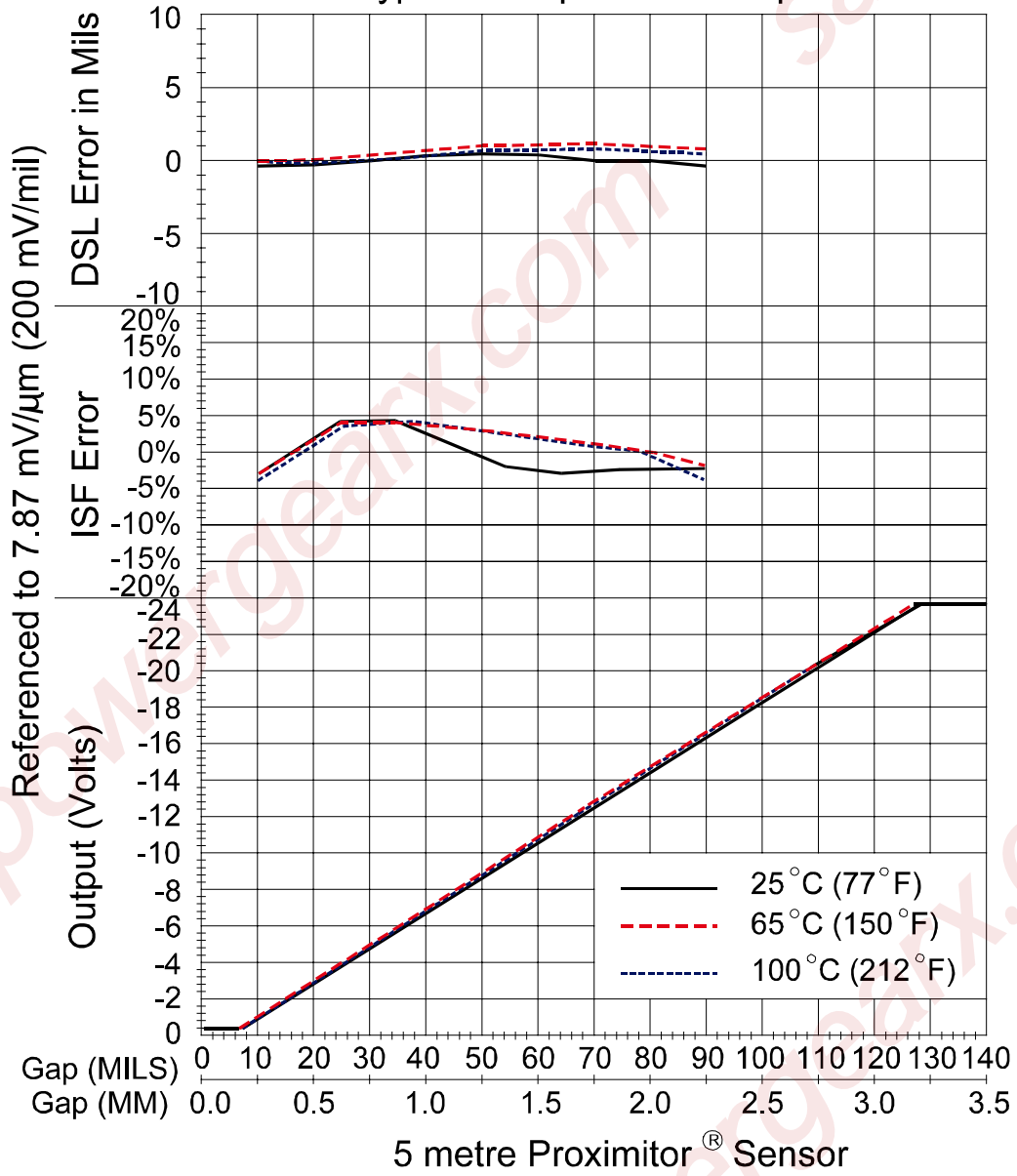

## Dimensional diagrams

### 3300 XL 8 mm Proximity Probes, Standard Mount

- 330101, 3/8-24 UNF-2A, without armor
- 330102, 3/8-24 UNF-2A, with armor
- 330103, M10X1 thread, without armor
- 330104, M10X1 thread, with armor

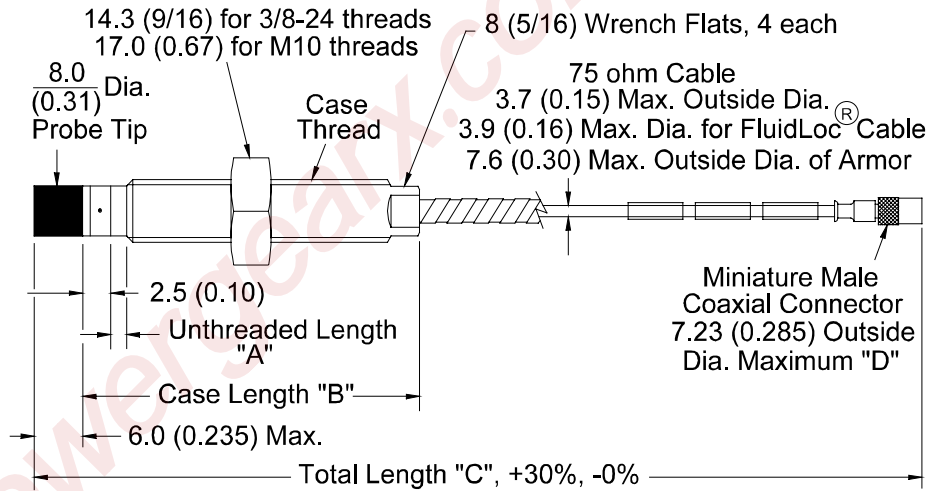

### 3300 5 mm Proximity Probes, Standard Mount

- 330171, 1/4-28 UNF-2A, without armor
- 330172, 1/4-28 UNF-2A, with armor
- 330173, M8X1 thread, without armor
- 330174, M8X1 thread, with armor

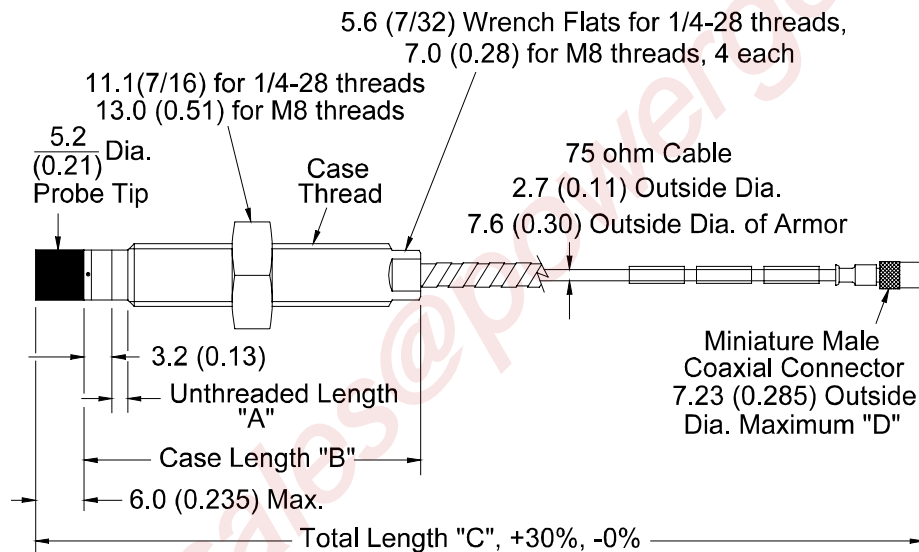

**Connector Protector**

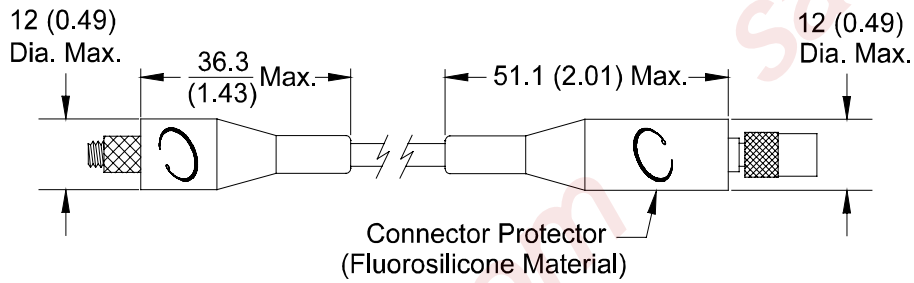

**3300 XL 8 mm Proximity Probes, Reverse Mount**

330105, 3/8-24 UNF-2A threads

330106, M10X1 threads

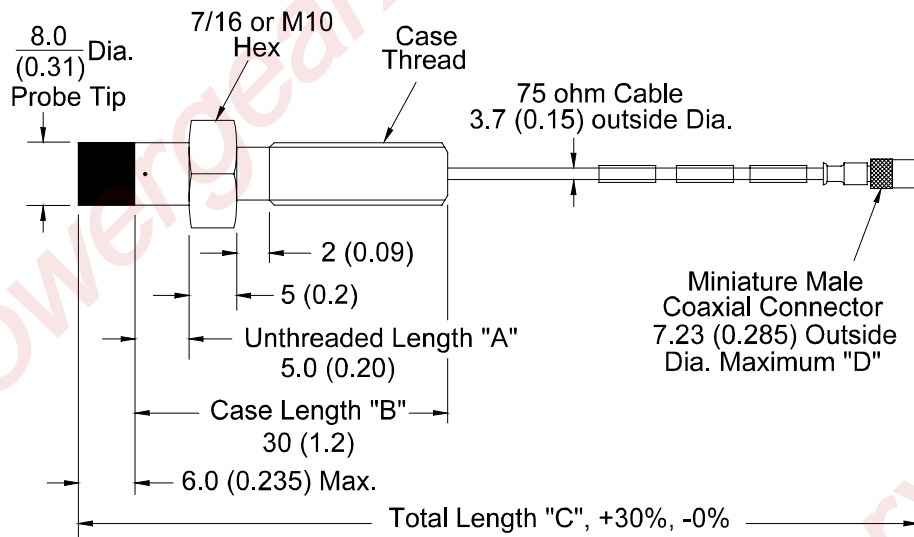

**3300 XL 8 mm Proximity Probes, Smooth Case**

330140, without armor

330141, with armor

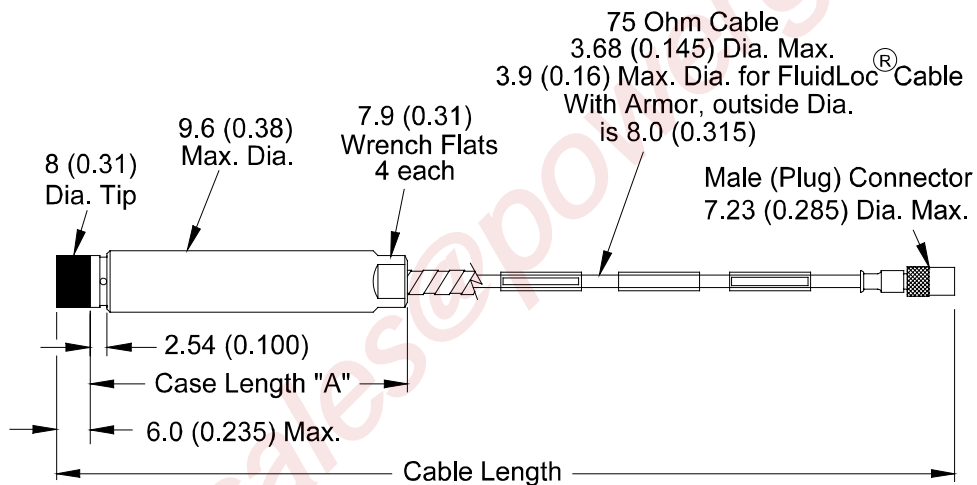

**3300 Proximator® Sensor**  
330100

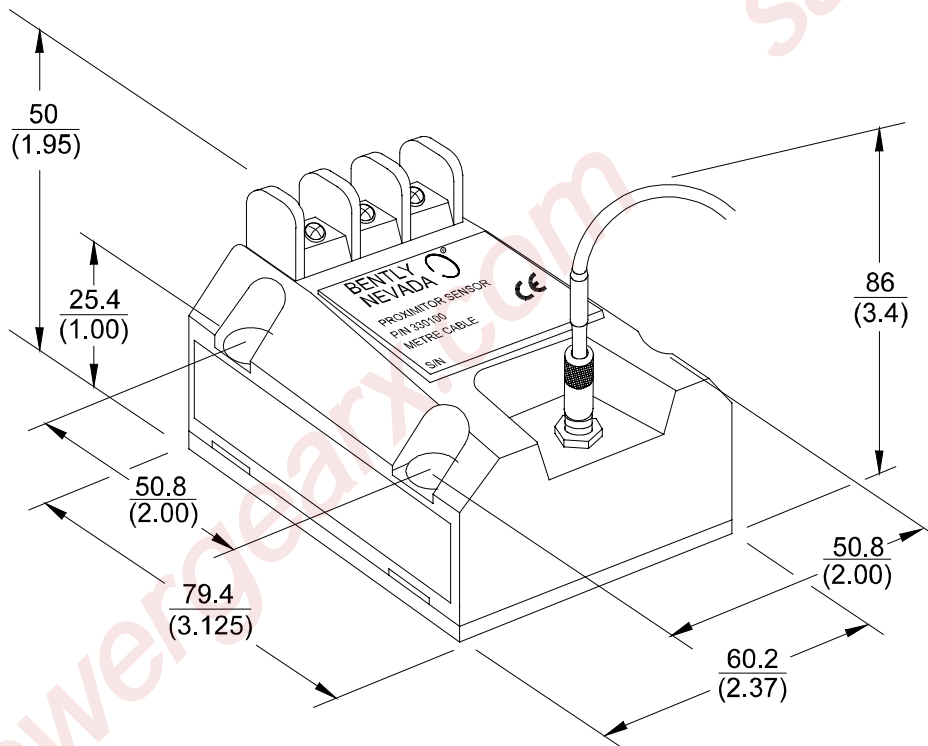

**3300 XL Extension Cable**  
330130

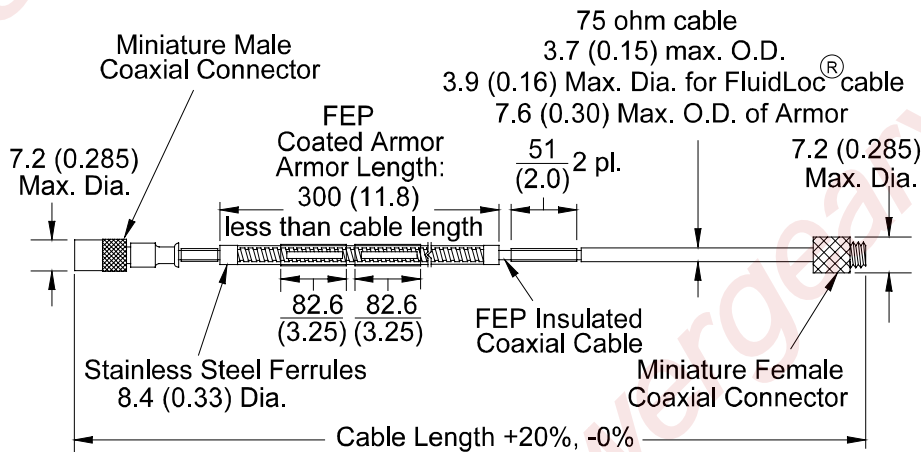

**Notes:**

1. All dimensions are in millimetres (inches) unless otherwise noted.
2. Standard mount 8 mm probes supplied with 17 mm or 9/16-in lock nut.
3. Standard mount 5 mm probes supplied with 13 mm or 7/16-in lock nut.
4. Reverse mount probes not available with armor, connector protector or FluidLoc® options.
5. Minimum cable bend radius is 25.4 mm (1.0 in) with or without armor.
6. Letters inside quotation marks refer to probe ordering options.
7. Stainless steel armor is supplied with FEP outer jacket.
8. FEP jacket is standard on all non-armored probes.
9. Probes ordered with 5 or 9 metre integral cables have a length tolerance of +20%, -0%.