

---

*The Tricon supports a comprehensive range of modules to meet customers' needs.*

## Product Specifications

---

The Triconex product family includes a comprehensive range of modules. This section includes: a summary of the system components and their uses, a table that lists standard products and their model numbers, and a summary of specifications for each standard product in the Tricon family

See the *Tricon Planning and Installation Guide* for complete information.

### Summary of Tricon Components

#### Chassis

- *Main Chassis*—houses Main Processors, memory back-up batteries, communication modules and I/O modules.
- *Expansion Chassis*—for additional I/O modules up to 100 feet (30 meters) away from the Main Chassis. In restricted applications, operation up to 1,000 feet (300 meters) is supported.
- *RXM Chassis*—for I/O modules up to 7.5 miles (12 kilometers) away from the Main Chassis.
- *Mechanical Keying*—Each slot in the Tricon is mechanically keyed to correspond with a specific type of module. This prevents the installation of modules into improper slots.

For chassis mounting and enclosure specifications, see [page 25](#).

#### Power Supply Modules

- Provide logic power to modules in the Main, Expansion or RXM Chassis. Available in 24 VDC, 115 VAC and 230 VAC versions. The power rating of each power supply is 175 watts at 140 ° F (60° C).

#### Main Processors

The Main Processors execute the system diagnostics and the user-written control program.

#### Communication Modules

- *Tricon Communication Modules (TCM)* support a number of Triconex protocols and applications and user-written applications on Ethernet (802.3) networks, including TriStation, Modbus TCP and OPC. It also supports RS-232 and RS-485 serial communication with Modbus devices, TriStation 1131, and GPS for time synchronization.
- *Enhanced Intelligent Communication Modules (EICM)* support RS-232, RS-422 and RS-485 serial communication with Modbus devices and TriStation 1131.
- *Network Communication Modules (NCM)* support a number of Triconex protocols and applications and user-written applications on Ethernet (802.3) networks, including TriStation 1131.
- *Safety Manager Modules (SMM)* act as an interface between a Tricon controller and a Honeywell Universal Control Network (UCN), one of three principal networks of the TDC-3000 DCS.
- *Hiway Interface Modules (HIM)* act as an interface between a Tricon controller and a Honeywell TDC-3000 Hiway Gateway and Local Control Network (LCN).
- *Advanced Communication Modules (ACM)* allow a Tricon controller to interface with a Foxboro Industrial

Automation (I/A) Series DCS and TriStation 1131.

#### Fiber-Optic Remote Extender Modules (RXM)

For operation of Expansion Chassis up to 7.5 miles (12 kilometers) away from the Main Chassis, with exceptional immunity against electro-static and electro-magnetic interference.

#### Interface Modules

- *HART Analog Input Interface Modules* act as an interface between 4-20 mA analog input points from HART smart devices in the field and HART Host software running on a PC.
- *HART Analog Output Interface Modules* act as an interface between 4-20 mA analog output points from HART smart devices in the field and HART Host software running on a PC.

#### I/O Modules

- *Digital Input Modules* receive discrete signals of these nominal voltages: 115 VAC/VDC, 48 VAC/VDC, and 24 VAC/VDC. All voltages are available in TMR modules. Non-TMR modules are available in 24 VDC and 48 VDC only. Speed input and totalization modules are also available.
- *Supervised Digital Output Modules* produce discrete output signals of these nominal voltages, with diagnostic coverage of the field circuit and load device: 115 VAC, 120 VDC, 48 VDC, and 24 VDC.
- *Digital Output Modules* produce discrete output signals of these nominal voltages: 115 VAC, 120

## Product Specifications

---

VDC, 24 VDC, and 48 VDC. Dual output modules are also available.

- *Analog Input Modules* receive analog signals of these types: 0-5 VDC, -5 to +5 VDC, 0-10 VDC, and Thermocouple types J, K, T and E.

Available in both isolated and DC-coupled versions.

- *Analog Output Modules* are available in these versions: eight output points at 4-20 mA; six output points at 4-20 mA and two at 20-320

mA; and four output points at -60 to 60 mA.

## Standard Tricon Products

Description	Model No.	See
<b>Chassis Assemblies</b>		
Main Chassis, High-Density Configuration, includes the Tricon printed manuals	8110	page 13, page 23
Expansion Chassis, High-Density Configuration	8111	page 13, page 23
Expansion Chassis, Enhanced Low-Density Configuration	8121	page 13, page 23
Remote Expansion Chassis, High-Density Configuration	8112	page 13, page 23
I/O Bus Expansion Cables (Set of 3)	9000 <sup>1</sup>	page 12
I/O-COMM Bus Expansion Cables (Set of 3)	9001	page 12, page 23
Blank I/O Slot Panel	8105	page 24
<b>Power Modules</b>		
120 VAC/VDC – 175-Watt Power Module	8310	page 26
24 VDC – 175-Watt Power Module	8311	page 26
230 VAC – 175-Watt Power Module	8312	page 26
<b>Main Processor Modules</b>		
3008 Main Processor, 16 megabytes DRAM	3008	page 27
<b>Communication Hardware and Software</b>		
Tricon Communication Module (TCM), Ethernet (802.3) and serial (RS-232/RS-485) ports	4351A, 4352A, 4351B, 4352B 4353, 4354	page 28
Enhanced Intelligent Communication Module (EICM), serial (RS-232/RS-422/RS-485) ports	4119, 4119A	page 29
Safety Manager Module (SMM), Honeywell UCN Interface	4409	page 30
Network Communication Module (NCM), Ethernet (802.3) ports	4329, 4329G	page 31
Advanced Communication Module (ACM), Foxboro I/A Series Nodebus Interface	4609	page 32
Hiway Interface Module (HIM), Honeywell Data Hiway Interface	4509	page 33
Triconex DDE Server Software	7523-2	page 63
Network Accessory Kit (Ethernet thin cable, connectors and terminators)	7600-3	n/a
<b>Remote Extender Modules</b>		
Primary RXM, Multi-Mode Fiber Optics, Set of 3 Modules	4200-3	page 34
Remote RXM, Multi-Mode Fiber Optics, Set of 3 Modules	4201-3	page 34
Primary SRXM, Single-Mode Fiber Optics, Set of 3 Modules	4210-3	page 34
Remote SRXM, Single-Mode Fiber Optics, Set of 3 Modules	4211-3	page 34
<b>Interface Modules</b>		
HART Analog Input Interface Module with 2071H HART Multiplexer	2770H	page 48
HART Analog Input Interface Module with 2071H HART Multiplexer and Amp-Elco Adapter Cable	2750-2H	page 48
HART Analog Output Interface Module with 2071H HART Multiplexer	2870H	page 48
HART Multiplexer	2071H	page 48

1. I/O Bus Expansion Cables are available in custom lengths. Please contact Triconex for more information.

# Product Specifications

Description	Model No.	See
<b>TriStation 1131 and Diagnostic Software</b>		
TriStation 1131 v4.x Software License with printed manuals	Contact Triconex	<a href="#">page 65</a>
Enhanced Diagnostic Monitor v2.x	Contact Triconex	<a href="#">page 66</a>
<b>Documentation Sets</b>		
Tricon Planning and Installation, Field Terminations, and Communication printed manuals	Contact Triconex	
Triconex User Documentation, includes all manuals in PDF format (CD-ROM)	Contact Triconex	

## Tricon I/O Modules

Voltage	Description	Type	Model No.	Points	For Details, See
<b>Digital Input Modules</b>					
115 VAC/VDC	Opto-Isolated, Non-Commoned	TMR	3501E/3501T	32	<a href="#">page 35</a>
48 VAC/VDC	Commoned in Groups of 8, Self-Test	TMR	3502E	32	<a href="#">page 35</a>
24 VAC/VDC	Commoned in Groups of 8, Self-Test	TMR	3503E	32	<a href="#">page 35</a>
24/48 VDC	High-Density, DC Coupled	TMR	3504E	64	<a href="#">page 36</a>
24 VDC	Low Threshold with Self-test, Commoned	TMR	3505E	32	<a href="#">page 35</a>
24 VDC	Single, Opto-Isolated, Commoned	Single	3564	64	<a href="#">page 36</a>
Pulse Input	Differential, AC Coupled	TMR	3511	8	<a href="#">page 37</a>
Pulse Totalizer	Opto-isolated, Non-commoned	TMR	3515	32	<a href="#">page 38</a>
<b>Digital Output Modules</b>					
115 VAC	Opto-Isolated, Non-commoned	TMR	3601E/3601T	16	<a href="#">page 39</a>
120 VDC	Opto-Isolated, Non-commoned Opto-Isolated, Commoned	TMR	3603B, 3603E/3603T	16	<a href="#">page 39</a>
24 VDC	Opto-Isolated, Non-commoned	TMR	3604E	16	<a href="#">page 39</a>
48 VDC	Opto-Isolated, Non-commoned	TMR	3607E	16	<a href="#">page 39</a>
115 VAC	Galvanically Isolated, Commoned., Supv.	TMR	3611E	8	<a href="#">page 41</a>
48 VDC	Galvanically Isolated, Commoned, Supv.	TMR	3617E	8	<a href="#">page 41</a>
120 VDC	Opto-Isolated, Commoned, Supervised	TMR	3623/3623T	16	<a href="#">page 40</a>
24 VDC	Opto-Isolated, Commoned, Supervised	TMR	3624	16	<a href="#">page 40</a>
24 VDC	Supervised/Non-Supervised, Commoned	TMR	3625	32	<a href="#">page 40</a>
24 VDC	Opto-Isolated, Commoned	Dual	3664	32	<a href="#">page 42</a>
24 VDC	Opto-Isolated, Commoned	Dual	3674	32	<a href="#">page 42</a>
Relay Output	Non-triplicated, Normally Open	Non-triplicated	3636R/3636T	32	<a href="#">page 37</a>

Voltage	Description	Type	Model No.	Points	For Details, See
<b>Analog Input Modules</b>					
0-5 VDC	Differential, DC Coupled	TMR	3700A	32	<a href="#">page 43</a>
0-10 VDC	Differential, DC Coupled	TMR	3701	32	<a href="#">page 43</a>
0-5, 0-10 VDC	Differential, Isolated	TMR	3703E	16	<a href="#">page 43</a>
0-5, 0-10 VDC	High-Density, Differential, DC Coupled	TMR	3704E	64	<a href="#">page 43</a>
Thermocouple	Differential, DC Coupled	TMR	3706A	32	<a href="#">page 46</a>
Thermocouple	Differential, Isolated	TMR	3708E	16	<a href="#">page 46</a>
0-5 VDC	Single-Ended	TMR	3720	64	<a href="#">page 43</a>
0 to 5 or -5 to +5 VDC	Differential, DC Coupled	TMR	3721	32	<a href="#">page 43</a>
<b>Analog Output Modules</b>					
4-20 mA	Current Loop, DC Coupled	TMR	3805E/3805H	8	<a href="#">page 44</a>
4-20 mA and 20-320 mA	Current Loop, DC Coupled	TMR	3806E	6 and 2	<a href="#">page 44</a>
-60 to 60 mA	BiPolar, Commoned Return, DC Coupled	TMR	3807	4	<a href="#">page 44</a>

## General Environmental and EMC Specifications

Other than the optional conformal coating of all PCB assemblies, the Tricon is not explicitly protected against dust, corrosive atmospheres or falling debris. Atmospheric and airborne-particle protection must be provided by housing the Tricon in an appropriate NEMA-rated enclosure.

Operating Temperature	32° to 140° F (0° to 60° C), ambient, as measured at the bottom of the chassis, per IEC 60068-2-1 Test Nb
Storage Temperature	-40° to 167° F (-40° to 75° C), per IEC 60068-2-14, Test Na
Relative Humidity	5% to 95%, non-condensing, per IEC 60068-2-2, Test Bb, and IEC 60068-2-3 test Db
Sinusoidal Vibrations per Axis	2 G @ 10 to 150 Hz, per IEC 60068-2-6, Test Fc
Shock	15 G for 6-11 ms in each axis, per IEC 60068-2-27
Electrostatic Discharge	IEC 61000-4-2, 8 kV air, 4 kV contact
Conducted Susceptibility	IEC 61000-4-4, Fast Transient/Burst, 2 kV power, 1 kV signal lines and IEC 61000-4-5, Surge Withstand, 2 kV CM AC power lines, etc. IEC 61000-4-6, RFI, 0.15-80 MHz, 10V
Radiated Susceptibility	IEC 61000-4-3, 26-1000 MHz, 10 V/m and IEC 61000-4-8, 50-60 Hz, 30 A/m
Conducted Emissions	CISPR 16, Class A, 0.15-30 MHz, 73-79 db when installed per the guidelines of the P&I Guide
Radiated Emissions	CISPR 11, Class A, 30-1000 MHz @ 10 m, 4-47 db when installed per the guidelines of P&I Guide
Cable Flame Test Rating <sup>1</sup>	<p><b>Interface cables</b> (connect external termination panels to I/O modules): FT4 Vertical Flame Test-Cables in Cable Trays per C.S.A. C22.2 No. 0.3-92 Para 4.11.4<sup>2</sup></p> <p><b>I/O bus cables</b> (connect chassis): FT6 Horizontal Flame &amp; Smoke Test-per C.S.A. C22.2 No. 0.3-92 Appendix B<sup>3</sup></p>

1. Applies to cables shipped after April 1, 2009.

2. Cables will be marked with FT4 or CMG rating, but they all actually meet the more stringent FT4 rating.

3. Cables will be marked with FT6 or CMR rating, but they all actually meet the more stringent FT6 rating.

# Product Specifications

---

## International Approvals

The Tricon controller has been certified as complying with multiple internationally recognized standards by the following internationally recognized certification agencies, these certifications have qualified the Tricon for use around the world in safety critical applications. Test reports from the various certification agencies are available upon request.

**TÜV Rheinland** — TÜV has certified that the Tricon v9 and v10 controllers are in full compliance with the internationally recognized standards listed below, and thus are qualified for use in the following applications and jurisdictions.

- Emergency safety shut-down or other critical control applications requiring SIL 1-3 certification per the functional safety requirements of IEC 61508 9 (only Tricon v9.6 or later)
- Emergency safety shut-down or other critical control applications requiring AK 1-AK6 certification per the functional safety requirements of DIN V 19250 and DIN V VDE 0801 (only Tricon v9.x)
- Fire and gas detection applications requiring certification per the requirements of EN 54
- Fire and gas detection applications requiring certification per the requirements of NFPA 72 (only Tricon v9.6 or later)
- Burner management applications requiring certification per the requirements of DIN VDE 0116
- Burner management applications requiring certification per the requirements of NFPA 8501 or NFPA 8502 (only Tricon v9.6 or later)
- All applications in the European Union or other jurisdictions requiring compliance with the EMC Directive No. 89/336/EEC and Low Voltage Equipment Directive No. 72/23/EEC
- All applications in the European Union or other jurisdictions requiring compliance with the ATEX Directive No. 94/9/EC for Zone 2, Group IIB hazardous locations
- Environmental, health, and safety applications in semiconductor manufacturing facilities per the requirements of SEMI S2

For hazardous location applications, see the *Tricon Planning and Installation Guide* for application-specific installation instructions.

**Canadian Standards Association (CSA)** — CSA has certified that the Tricon v10 controller is in full compliance with the internationally recognized electrical safety standards and is qualified for general use in North American and other jurisdictions requiring compliance with these standards.

**Factory Mutual Research (FM)** — Factory Mutual has certified that the Tricon v10 controller is in full compliance with the international recognized standards and is qualified for use in Class I, Division 2 Temperature T4, Groups A, B, C, and D hazardous indoor (or outdoor in a NEMA 4 cabinet) locations. For hazardous location applications, see the *Tricon Planning and Installation Guide* for application-specific installation instructions.

**European Union CE Mark** — Based upon the independent TÜV evaluation and test results, Triconex has certified the Tricon controller is suitable to use in the European Union and all other jurisdictions requiring compliance with the European Union EMC Directive No. 89/336/EEC and Low Voltage Equipment Directive No. 72/23/EEC, see Certificate of Compliance for details. For hazardous location applications, see the *Tricon Planning and Installation Guide* for application-specific installation instructions.

**U.S. Nuclear Regulatory Commission (NRC)** — The NRC has certified that the Tricon controller is suitable for use in nuclear 1E applications within the limitations and guidelines referenced in the NRC Safety Evaluation Report (SER) ML013470433, *Review of Triconex Corporation Topical Reports 7286-545, "Qualification Summary Report" and 7286-546, "Amendment 1 To Qualification Summary Report," Revision 1*. This report is available from the NRC via the Agency Document Access and Management System (ADAMS) Web site. This qualification was based upon EPRI TR-107330, *Generic Requirements Specification for Qualifying a Commercially Available PLC for Safety-Related Applications in Nuclear Power Plants*. For details on models and revisions qualified for 1E applications, please contact Invensys Nuclear by calling toll-free 866-703-6300, toll 949-885-0885, or visit the Invensys Nuclear Web site at <http://www.invensysnuclear.com>.

## Chassis Options

A Tricon system is made up of one or more chassis assemblies which contain I/O and communication modules. The first chassis of a system is called the Main Chassis (Model 8110). To enlarge a system, Expansion Chassis (Model 8111 or 8121) and/or RXM Chassis (Model 8112) can be added. (See “System Configuration” on page 11 for details.)

## I/O Expansion Bus

Each chassis has six RS-485 I/O expansion bus ports at the top left corner of the backplane. There are two sets of ports for channels A, B, and C, providing for two triplicated serial communications paths between chassis. One set of cables is required for each Expansion Chassis and for the RXM Chassis which houses the primary RXM Module set. The standard length of a cable set (Model 9000) is 6 feet—longer cables are available if needed.

The triplicated I/O bus transfers data between the I/O modules and the Main Processors at 375 kilobits per second. The communication bus runs between the Main Processors and the communication modules at 2 megabits per second.

## Mechanical Specifications

These specifications apply to Main, Expansion and RXM Chassis; Power Supply Modules; and other modules where indicated.

Overall Dimensions	19 in wide by 22.75 in high by 17.75 in deep (48.3 cm by 57.8 cm by 45.1 cm)
Chassis Fabrication	Black zinc-plated and welded cold-rolled steel
Approximate Weights	
Main or Expansion Chassis	54.0 lbs. (24.5 kg.)
Power Module	7.2 lbs. (3.3 kg.)
Main Processor	4.7 lbs. (2.1 kg.)
I/O Module	4.7 to 6.0 lbs. (2.1 kg. to 2.7 kg.)
HART Interface Module	4.8 lbs. (2.2 kg.)
Communication Module	5.0 lbs. (2.3 kg.)
16-point Termination Panel	.09 lbs. (.04 kg.)
32-point Termination Panel	2.1 lbs. (.95 kg.)

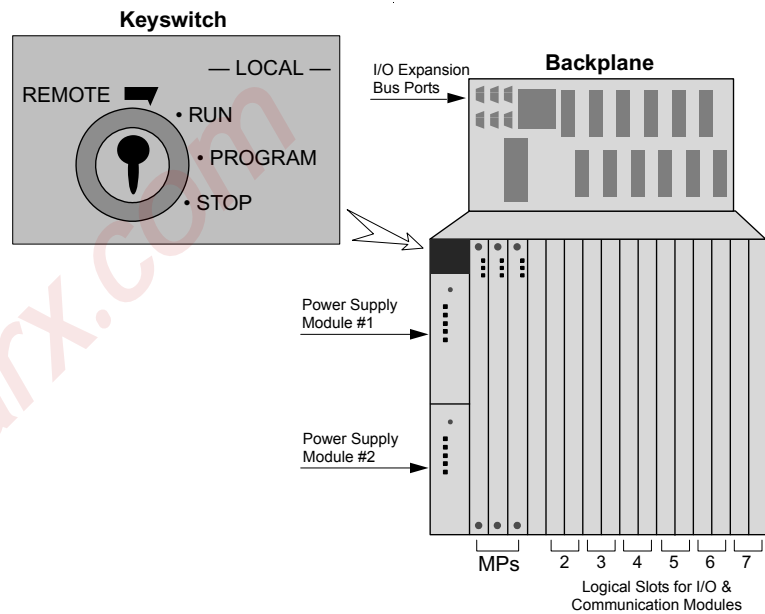

## Keyswitch for System Control

The Main Chassis has a four-position keyswitch which controls all the chassis in the system. The keyswitch setting is readable by Tricon controllers, TriStation 1131 software, and the control programs. Switch settings are:

*RUN*—Normal operation with read-only capability. The Main Processors

execute the previously-loaded control program. Attempts to modify program variables by TriStation 1131, Modbus masters, or external hosts are rejected. However, a control program may call gated access functions to enable external host writes during a designated window of time.

*PROGRAM*—For program loading and checkout. Allows control of the Tricon system from the TriStation 1131 platform, including Download All and Download Changes. Also allows writes to program variables by external hosts.

*STOP*—Stops reading inputs, forces non-retentive digital and analog outputs to 0, and halts the control program. (Retentive outputs retain the value they had before the keyswitch was turned to Stop.) The Stop setting can be used for installation and service of process-related equipment, *but is not required for service of the Tricon.*

*REMOTE*—Allows writes to program variables by TriStation 1131 and external hosts. (Download All and Download Changes by TriStation 1131 are not allowed.) Modification of program logic is not allowed.

# Product Specifications

## Chassis and Mounting Specifications

The Tricon system can be rack-mounted or panel-mounted in an industry-standard NEMA enclosure as described on the next page. Cabinets can optionally be equipped with base and casters. Multiple cabinets can be bolted together on the sides, but sufficient clearance must be allowed to fully open their front and rear doors.

## Slot Covers

All unused slots in a chassis should be filled with Blank I/O Slot Panels (Model 8105) to maintain proper air flow.

## Heat Management

When mounting Tricon chassis into vented or non-vented enclosures, the

integration engineer must make provisions for sufficient heat management.

Triconex recommends the installation of baffles (Triconex part number 2000361-001), as shown on page 23. For temperatures above 122° F (50° C), other heat management provisions must be implemented, such as:

- Louvers and pagoda top
- Enlarged front and rear louvers with raised pagoda top
- Lower density filters
- Redundant fans (running all the time) with appropriate louvers and pagoda top
- Failure detection circuitry

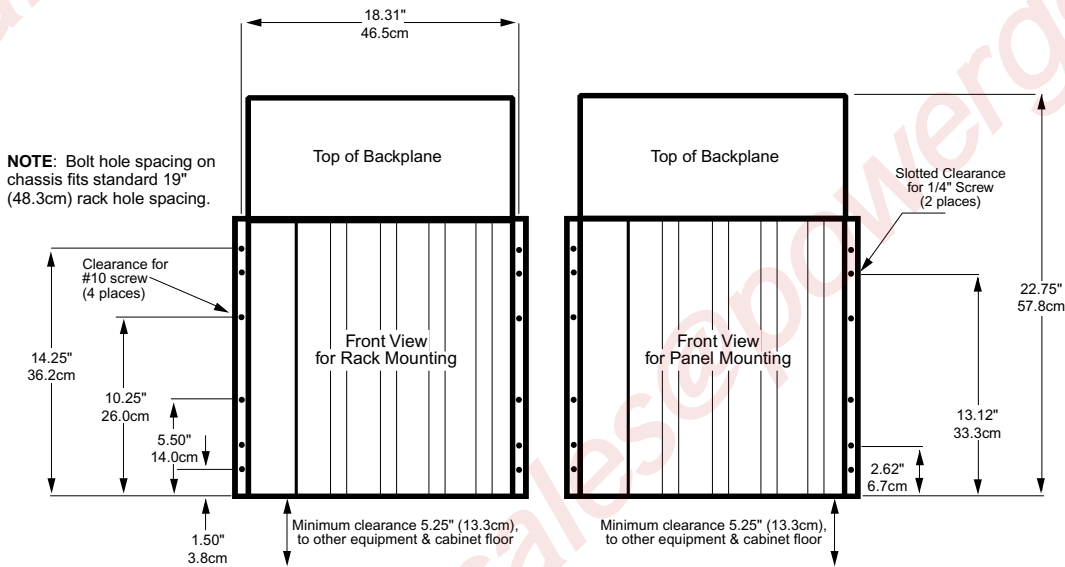
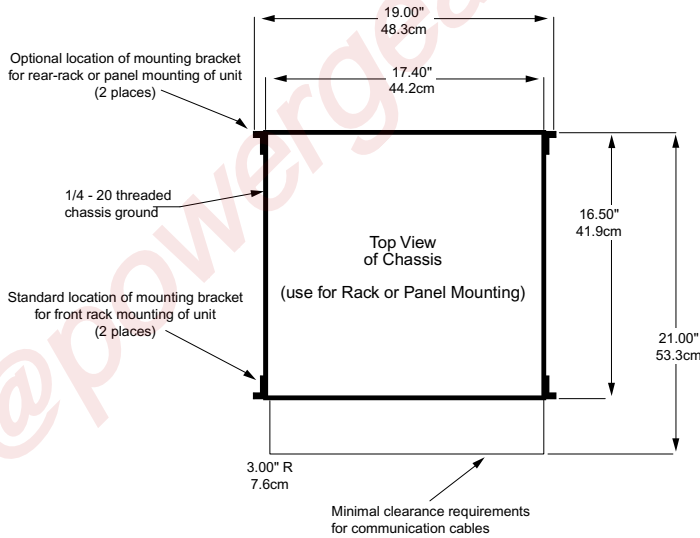

Dimensions and Clearances for Rack and Panel Mounting



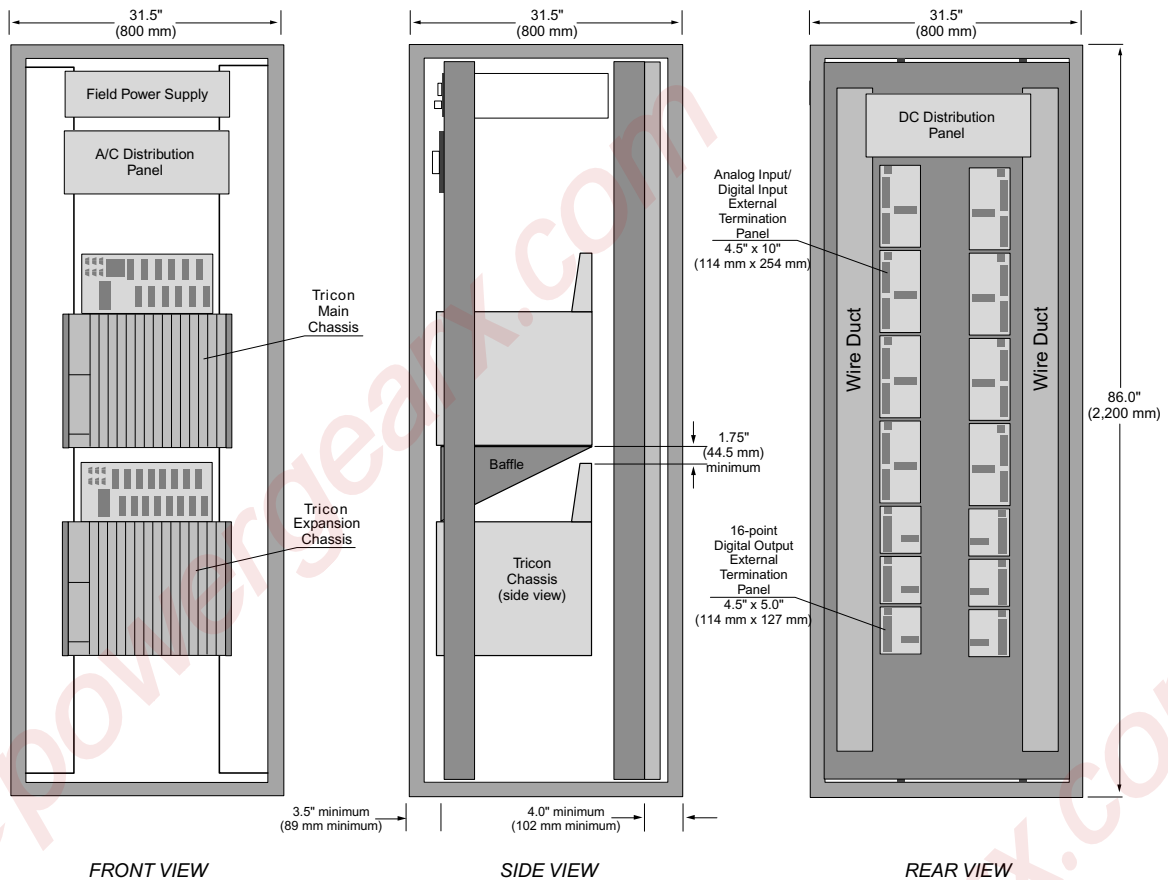

**Typical Dimensions and Clearances for Chassis Installation with External Terminations**

**NOTE**

*This drawing shows a typical set-up for external termination panels—other set-ups are possible. Please contact the IPS Global Client Support (GCS) center for details.*

**Mounting Tricon Chassis in Enclosures**

Triconex will mount Tricon chassis in any of the industry-standard enclosures listed below. (Please contact Triconex regarding other enclosures, available for additional engineering and documentation charges.) See page 14 for a photograph of Tricon chassis and terminations mounted in a sample enclosure.

**Enclosures Typically Supported by Triconex\***

Type	Width	Depth	Height
Rittal NEMA 12	31.5 inches (800 mm)	31.5 inches (800 mm)	86.0 inches (2,200 mm)
	31.5 inches (800 mm)	31.5 inches (800 mm)	78.0 inches (2,000 mm)
MarkHon NEMA 1	31.5 inches (800 mm)	31.5 inches (800 mm)	85.0 inches (2,160 mm)

\* Other sizes are available. Please contact Triconex for more information.

# Product Specifications

## Power Modules

Each Tricon chassis is equipped with two Power Modules—either one is fully capable of running the Tricon at full load and rated temperature. Each Power Module can be replaced online. The Power Modules, located on the left side of the chassis, convert line power to DC power appropriate for all Tricon modules. Terminal strips for system grounding, incoming power and hard-wired alarms are located on the lower left corner of the backplane. Incoming power should be rated for a minimum of 240 watts per power supply.

The Power Module alarm contacts are actuated when:

- A module is missing from the system

- The hardware configuration conflicts with the control program’s logical configuration
- A module fails
- A Main Processor detects a system fault
- Primary power to a Power Module fails
- A Power Module has a “Low Battery” or “Over Temperature” warning

**WARNING:** Do not use the Model 8312 Power Module in Tricon systems that are located in hazardous locations and must meet ATEX requirements. If you have 230 V line voltage and your system must meet ATEX requirements, use the Model 8311 24 VDC Power

Module along with the ATEX-certified 24 VDC power supply from Phoenix Contact (part number: QUINT-PS-100-240AC/24DC/10/EX).

**Front Panel of Power Module:**  
(located on lower left side of chassis)

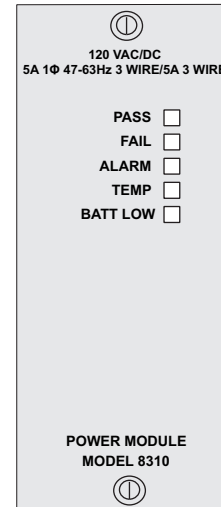

## Power Module Specifications

Isolation	>1,000 VAC or 1,500 VDC, Input to Output
Input Terminations	Protected by safety cover Accepts three 12-gauge wires (3.310mm <sup>2</sup> ): neutral, hot, and protective earth (chassis ground)
Over-Temp. Sensor	Temperature warning monitor—trips when internal temp. is greater than 181° F (83°C); this typically occurs at ambient temperature 140°F (60°C) or higher
Alarm Contacts	Normally open, normally closed and common Each contact supports 120 VAC @ 1 amp Accepts 12-gauge (3.310mm <sup>2</sup> ) wire Protected by safety cover
Input Power Required	240 watts minimum per Power Module
Output Power	175 watts at 140°F (60°C)
Output Voltage	6.5 VDC, ±1% under all operating conditions
Output Current	27 amps maximum at 140°F (60°C) ambient

**Terminal Strip for Power Module:**  
(located on backplane above the Power Module)

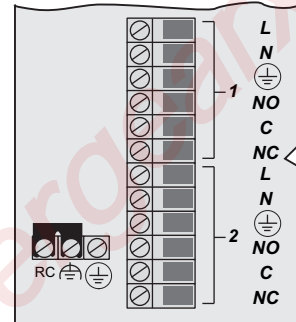

Power Module Model	8310	8311	8312
Chassis Type	Main/Expansion/RXM	Main/Expansion/RXM	Main/Expansion/RXM
Nominal Voltage	120 VAC/VDC	24 VDC	230 VAC
Input VAC @ 47-63 Hz	85–140	n/a	185–285
Input VDC	95–180	22–31	n/a
Fuse Rating and Type	5 amps, time-delay	15 amps, time-delay	2.5 amps, time-delay
Output Hold Time (nominal to 0 volts)	20 ms minimum	2.8 ms minimum	20 ms minimum
Diagnostic Indicators	PASS, FAULT, ALARM, TEMP, BAT LOW	PASS, FAULT, ALARM, TEMP, BAT LOW	PASS, FAULT, ALARM, TEMP, BAT LOW

## Main Processor Modules

Model 3008 Main Processors (MP) are available for Tricon v9.6 and later systems. For detailed specifications, see the *Planning and Installation Guide for Tricon Systems*.

Three MPs must be installed in the Main Chassis of every Tricon system. Each MP independently communicates with its I/O subsystem and executes the user-written control program.

### Sequence of Events (SOE) and Time Synchronization

During each scan, the MPs inspect designated discrete variables for state changes known as *events*. When an event occurs, the MPs save the current variable state and time stamp in the buffer of an SOE block.

If multiple Tricon systems are connected by means of NCMs, the time synchronization capability ensures a consistent time base for effective SOE time-stamping. See [page 72](#) for more information.

### Diagnostics

Extensive diagnostics validate the health of each MP, I/O module and communication channel. Transient faults are recorded and masked by the hardware majority-voting circuit. Persistent faults are diagnosed and the errant module is hot-replaced.

MP diagnostics perform these tasks:

- Verify fixed-program memory and static RAM

- Test all basic processor and floating-point instructions and operating modes
- Validate user memory by means of the TriBus hardware-voting circuitry
- Verify the shared memory interface with each I/O communication processor and channel
- Verify handshake and interrupt signals between the CPU, each I/O communication processor and channel
- Check each I/O communication processor and channel microprocessor, ROM, shared memory access and loopback of RS-485 transceivers
- Verify the TriClock and TriBus interfaces

## Physical Description of Model 3008 Main Processors

Feature	Description
Microprocessor	Motorola MPC860, 32 bit, 50 MHz
Memory	<ul style="list-style-type: none"> <li>• 16 MB DRAM (non-battery backed-up)</li> <li>• 32 KB SRAM, battery backed-up</li> <li>• 6 MB Flash PROM</li> </ul>
Tribus Communication Rate	<ul style="list-style-type: none"> <li>• 25 megabits per second</li> <li>• 32-bit CRC protected</li> <li>• 32-bit DMA, fully isolated</li> </ul>
I/O Bus and Communication Bus Processors	<ul style="list-style-type: none"> <li>• Motorola MPC860</li> <li>• 32 bit</li> <li>• 50 MHz</li> </ul>

## Indicators on Main Processors

PASS	Module has passed self-diagnostic tests
FAULT	Module has a fault and should be replaced
ACTIVE	Module is executing the user-written control program
MAINT1	Maintenance indicator 1
MAINT2	Maintenance indicator 2
COM TX	Transmitting data across COMM bus
COM RX	Receiving data from COMM bus
I/O TX	Transmitting data across I/O bus
I/O RX	Receiving data from I/O bus

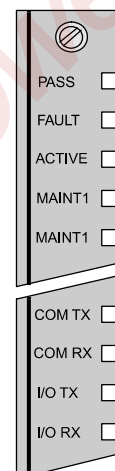

## Tricon Communication Module

The Tricon Communication Module (TCM), which is compatible with only Tricon v10.0 and later systems, allows the Tricon to communicate with TriStation 1131, other Tricon or Trident controllers, Modbus master and slave devices, and external hosts over Ethernet networks.

Each TCM contains four serial ports, two network ports, and one debug port (for Triconex use).

Each serial port is uniquely addressed and can be configured as a Modbus master or slave. Serial Port #1 supports either the Modbus or the Trimble GPS interface. Serial Port #4 supports either the Modbus or the TriStation interface. Each TCM supports an aggregate data rate of 460.8 kilobits per second, for all four serial ports.

Any standard Modbus device can communicate with the Tricon through the TCM, provided that aliases are assigned to the Tricon variables. Alias numbers must also be used when host

# Product Specifications

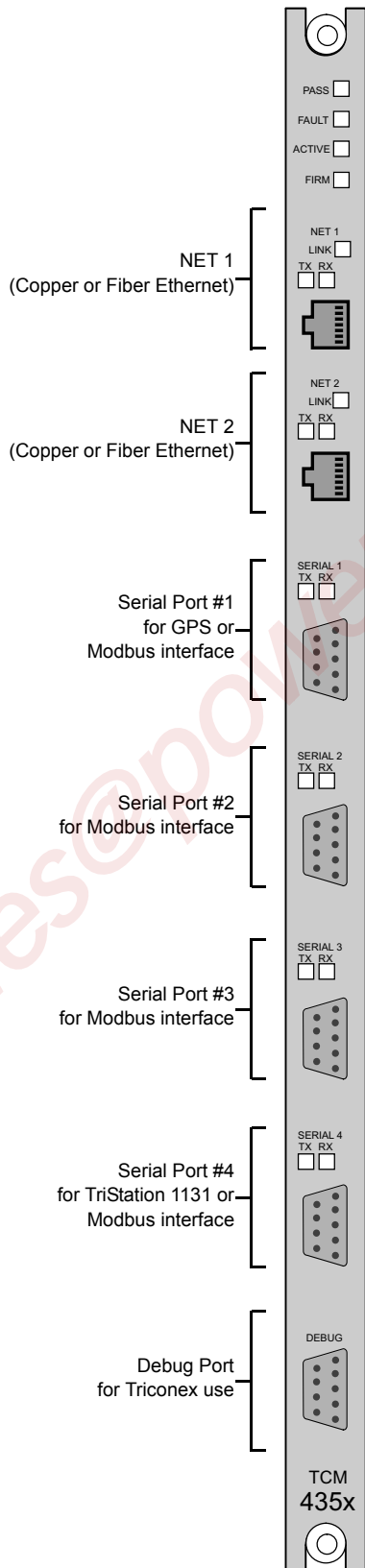

computers access the Tricon through other communication modules. See “Communication Capabilities” on page 61 for more information.

TCM Models 4353 and 4354 have an embedded OPC server on NET 2, which allows up to 10 OPC clients to subscribe to data collected by the OPC Server. The embedded OPC Server supports the Data Access 2.05 standard and the Alarms and Events 1.10 standard.

Each TCM contains two network ports—NET 1 and NET 2. Models 4351A, 4351B, and 4353 have two copper Ethernet (802.3) ports and Models 4352A, 4352B, and 4354 have two fiber-optic Ethernet ports.

On TCM Models 4351A, 4351B, 4352A, and 4352B, NET 1 and NET 2 support the TCP/IP, Modbus TCP/IP Slave/Master, TSAA, TriStation, SNTP, and Jet Direct (for network printing) protocols. NET 1 also supports the Peer-to-Peer (UDP/IP) and

Peer-to-Peer Time Synchronization protocols.

On TCM Models 4353 and 4354, NET 2 supports only the embedded OPC server, TriStation, and SNTP protocols, while NET 1 supports all of the listed protocols except the embedded OPC server.

A single Tricon system supports a maximum of four TCMs, which must reside in two logical slots. Different TCM Models cannot be mixed in one logical slot. Each Tricon system supports a total of 32 Modbus masters or slaves—this total includes network and serial ports. The hot-spare feature is not available for the TCM, though you *can* replace a faulty TCM while the controller is online.

## TCM Specifications

<b>Model Number</b>	<b>4351A, 4351B, 4352A, 4352B, 4353, 4354</b>	
Serial ports	4, RS-232/RS-485 ports, DB-9 connectors	
Network ports	2, 10/100BaseT Ethernet ports, RJ-45 connectors (Models 4351A, 4351B, 4353) 2, fiber-optic mode Ethernet ports, MT-RJ connectors with 62.5/125 um fiber cables (Models 4352A, 4352B, 4354)	
Port isolation	500 VDC	
Protocols	TriStation, Modbus, TCP/IP, ICMP, SNTP, TSAA (with support for IP Multicast), Trimble GPS, Embedded OPC Server (Models 4353 and 4354), Peer-to-Peer (UDP/IP), Peer-to-Peer Time Synchronization, Jet Direct (network printing)	
Modbus functions supported	01 — Read Coil Status 02 — Read Input Status 03 — Read Holding Registers 04 — Read Input Registers 05 — Modify Coil Status	06 — Modify Register Content 07 — Read Exception Status 08 — Loopback Diagnostic Test 15 — Force Multiple Coils 16 — Preset Multiple Registers
Communication speed	Copper Ethernet ports: 10/100 Mbps (Model 4353 supports only 100 Mbps) Fiber Ethernet ports: 100 Mbps Serial ports: up to 115.2 Kbps per port	
Status Indicators	PASS, FAULT, ACTIVE, FIRM LINK— 1 per network port, TX (Transmit) — 1 per port, RX (Receive) — 1 per port	

## Enhanced Intelligent Communication Module

The Model 4119A Enhanced Intelligent Communication Module (EICM) allows the Tricon to communicate with Modbus masters and slaves, TriStation 1131, and printers.

For Modbus connections, the EICM user can select the RS-232 point-to-point interface for one master and one slave, or the RS-485 interface for one master and up to 32 slaves. The RS-485 network trunk can be one or two twisted-pair wires up to a maximum of 4,000 feet (1,200 meters).

Each EICM contains four serial ports and one parallel port which can operate concurrently. Each serial port can be configured as a Modbus master with up to seven Modbus masters per Tricon chassis. A single Tricon system supports a maximum of two EICMs, which must reside in one logical slot. (The hot-spare feature is not available for the EICM, though you can replace a faulty EICM while the controller is online.) Each serial port is uniquely addressed and supports either the Modbus or TriStation interface.

Modbus communication can be performed in either RTU or ASCII mode. The parallel port provides a Centronics interface to a printer.

Each EICM supports an aggregate data rate of 57.6 kilobits per second (for all four serial ports).

Programs for the Tricon use variable names as identifiers but Modbus devices use numeric addresses called *aliases*. Therefore an alias must be assigned to each Tricon variable name that will be read by or written to a Modbus device. An alias is a five-digit number which represents the Modbus message type and the address of the variable in the Tricon. An alias number is assigned in TriStation 1131.

Any standard Modbus device can communicate with the Tricon through the EICM, provided that aliases are assigned to the Tricon variables. Alias numbers must also be used when host computers access the Tricon through other communication modules, such as the NCM. See “Communication Capabilities” on page 61 for more information.

### EICM Specifications

Model Number	4119A, Isolated
Serial ports	4 ports RS-232, RS-422 or RS-485
Parallel ports	1, Centronics, isolated
Port isolation	500 VDC
Protocol	TriStation, Modbus
Modbus functions supported	01 — Read Coil Status 02 — Read Input Status 03 — Read Holding Registers 04 — Read Input Registers 05 — Modify Coil Status 06 — Modify Register Content 07 — Read Exception Status 08 — Loopback Diagnostic Test 15 — Force Multiple Coils 16 — Preset Multiple Registers
Communication speed	1200, 2400, 9600, or 19,200 Baud
Diagnostic Indicators	Pass, FaULT, Active TX (Transmit) — 1 per port RX (Receive) — 1 per port

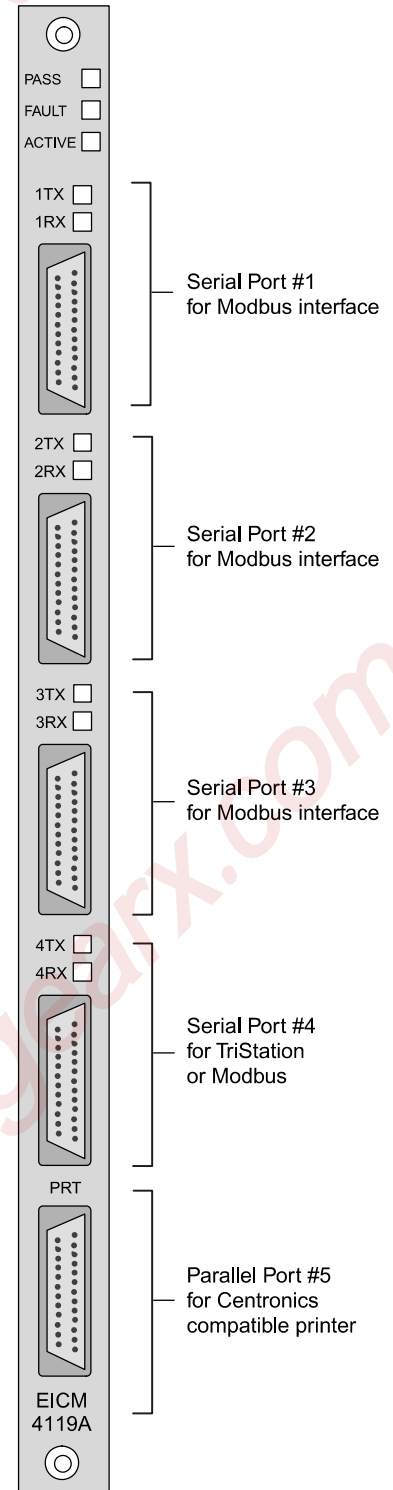

# Product Specifications

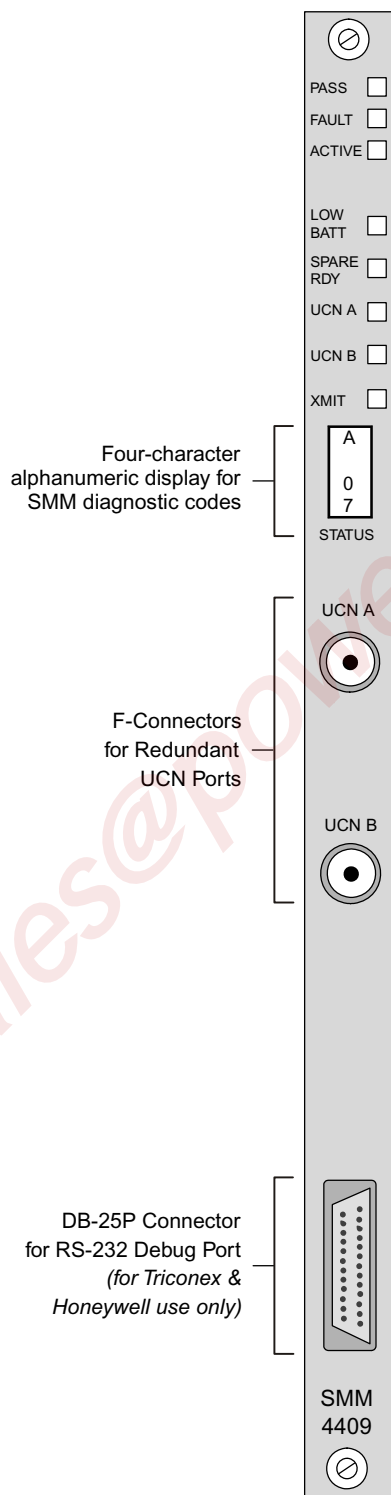

## Safety Manager Module

The Model 4409 Safety Manager Module (SMM) acts as an interface between a Tricon controller and a Honeywell Universal Control Network (UCN), one of three principal networks of the TDC-3000 Distributed Control System. Appearing to the Honeywell system as a safety node on the UCN, the SMM communicates process information at full network data rates for use anywhere on the TDC-3000. The SMM transmits Tricon aliased data (including system variables) and diagnostic information to operator workstations in display formats that are familiar to Honeywell operators.

The SMM makes the following functions available to the TDC-3000:

- Handles critical I/O points and passes results to the DCS
- Processes Tricon alarms and propagates them to user-defined DCS destinations (consoles, printers, etc.)
- Reads/writes aliased data to satisfy DCS requests

- Reads Tricon diagnostics for display by the DCS
- Write protection to lock out changes to the Tricon controller from all TDC-3000 sources
- *Time synchronization* from the DCS master clock
- *Peer-to-Peer communication* for plants with many Tricon controllers, each containing an SMM—the DCS can use shared data to alert downstream Tricons of significant process changes
- *Sequence of Events*—transmits Tricon event data to Universal Stations for display or History Modules for recording, to help determine the cause of plant trips and increase process up-time
- Hot-spare capability for uninterrupted communication with Honeywell networks

## SMM Specifications

<b>Model Number</b>	<b>4409</b>
UCN ports	2 isolated (AC coupled)
UCN data rate	5 MBytes per second
Status indicators	PASS (Module Status) FAULT (Module Status) ACTIVE (Module Status) LOW BATT (Low Battery) SPARE RDY (Hot Spare Ready) UCN A (UCN Port A Active) UCN B (UCN Port B Active) XMIT (SMM Transmitting) STATUS (Module Node and Diagnostic Info.)
Power Module load	< 20 watts
Isolation	500 VDC

## Network Communication Module

With a Model 4329 Network Communication Module (NCM) installed, the Tricon can communicate with other Tricons and with external hosts over Ethernet (802.3) networks. The NCM supports a number of Triconex proprietary protocols and applications as well as user-written applications, including those that use TSAA protocol.

The NCMG module has the same functionality as the NCM, as well as the ability to synchronize time based on a GPS system. For more information, see the *Communication Guide for Tricon Systems*.

The NCM provides two BNC connectors as ports: NET 1 supports Peer-to-Peer and Time Synchronization protocols for safety networks comprised of Tricons only. NET 2 supports open networking to external systems using Triconex applications such as TriStation 1131, SOE, OPC Server, and DDE

Server or user-written applications. See “Communication Capabilities” on page 61 for more information about Triconex protocols and applications.

Two NCMs can reside in one logical slot of the Tricon chassis, but they function independently, not as hot- spare modules. External hosts can read or write data only to Tricon variables to which Alias numbers have been assigned. (See “Enhanced Intelligent Communication Module” on page 29 for more information about Aliases.)

The NCM is compatible with Ethernet (IEEE 802.3 electrical interface) and operates at 10 megabits per second. The NCM connects with external host computers by means of coaxial cable (RG58) at typical distances up to 607 feet (185 meters). Distances up to 2.5 miles (4,000 meters) are possible using repeaters and standard (thick-net or fiber-optic) cabling.

The Main Processors typically refresh data on the NCM once per scan.

## NCM Specifications

Model Number	4329, 4329G
Ethernet (802.3) ports	2, BNC connectors, RG58 50-ohm thin cable
External Transceiver Ports	2, 15-pin D-connectors
Serial port	1, RS-232 compatible
Port Isolation	500 VDC
Protocol	TSAA (TCP(UDP)/IP/802.3)
Functions supported	TRICON_DATA (Frame Type 1) TRICON_DATA_REQ (Frame Type 2) WRITE_TRICON_DATA (Frame Type 3) WRITE_TRICON_DATA_RSP (Frame Type 4) READ_TRICON_CLOCK (Frame Type 5) READ_TRICON_CLOCK_RSP (Frame Type 6) SET_TRICON_CLOCK (Frame Type 7) SET_TRICON_CLOCK_RSP (Frame Type 8) READ_TRICON_DATA (Frame Type 11) READ_TRICON_RSP (Frame Type 12)
Communication speed	10 megabits per second (for Ethernet ports)
Status indicators	PASS, FAULT, ACTIVE TX (Transmit) — 1 per port RX (Receive) — 1 per port

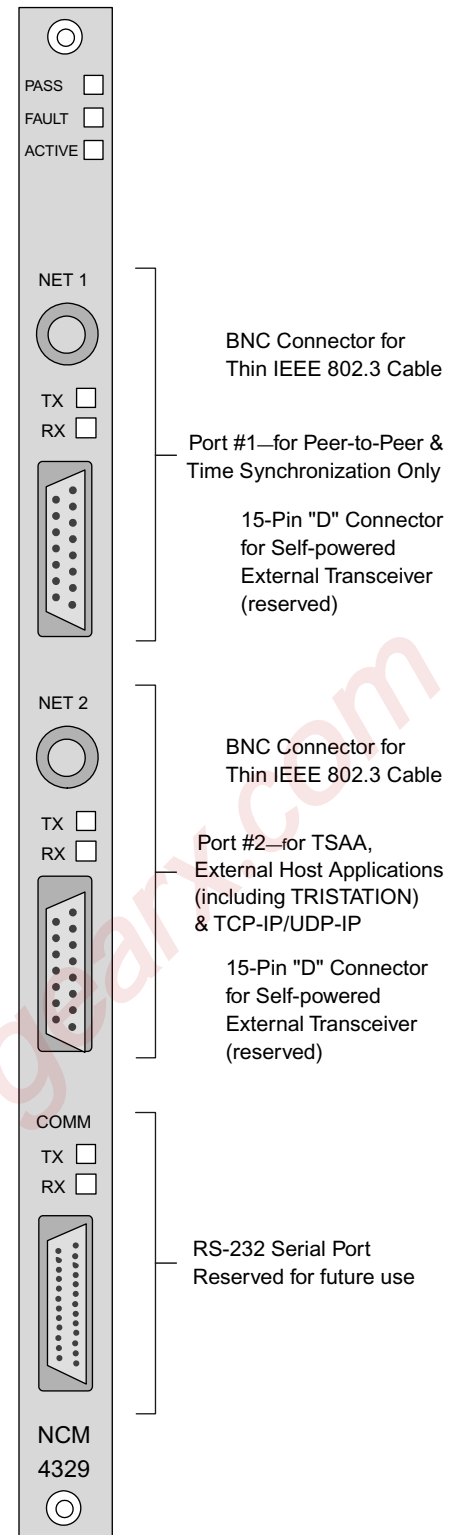

# Product Specifications

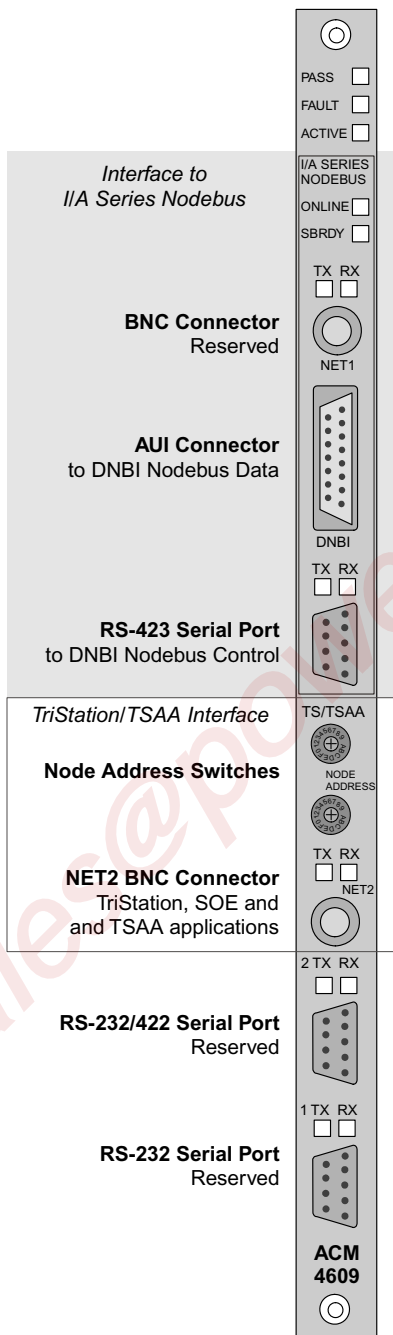

## Advanced Communication Module (ACM)

The Model 4609 Advanced Communication Module (ACM) acts as an interface between a Tricon controller and a Foxboro Intelligent Automation (I/A) Series system, appearing to the Foxboro system as a safety node on the I/A Series Nodebus. The ACM communicates process information at full network data rates for use anywhere on the I/A Series system, transmitting all Tricon aliased data (including system variables and system aliases) and diagnostic information to operator workstations in display formats that are familiar to Foxboro operators. The ACM makes the following functions available to the I/A Series:

- Handles critical I/O points and passes results to the I/A Series using the Object Management Database (OMDB)
- Processes Tricon alarms and propagates them to user-defined I/A Series destinations (consoles, printers, etc.)

- Propagates Tricon alarms as I/A Series system messages
- Reads/writes aliased data to satisfy I/A Series requests
- Time synchronization from the I/A Series environment
- Reads Tricon diagnostics for display by the I/A Series workstation
- Write protection to lock out changes to the Tricon controller from all I/A Series sources
- Hot-spare capability for uninterrupted communication with the I/A Series Nodebus

The ACM also supports the following Triconex protocols and applications on external host PCs connected to a separate BNC port (labeled NET 2):

- Tristation protocol for the TriStation 1131 software
- TSAA protocol for Triconex applications
- TSAA/TCP (UDP/IP) for user-written applications on external hosts

## ACM Specifications

Model Number	4609
Nodebus Ports	
BNC connector	1 for RG58 50-ohm thin cable (reserved)
15-pin D connector	1 for AUI cable to DNBI
9-pin RS-423 connector	1 for Control Bus to DNBI
NET 2 port <sup>1</sup>	1 BNC connector for RG58 50-ohm Thin cable to Ethernet network
9-pin serial ports	RS-232/RS-485 protocol (reserved)
Port isolation	500 VDC (Ethernet and RS-232 ports)
Communication speeds	
BNC and 15-pin D connectors	10 megabits per second
9-pin Nodebus connector	2400 baud
Status indicators	
Module status	PASS, FAULT, ACTIVE
Nodebus/standby activity	ONLINE and SBRDY
Port activity	TX and RX—1 each per port
Power Module load	20 watts

1. The address for this port is set by the TS/TSAA Node Addresses switches.



## Hiway Interface Module

The Model 4509 Hiway Interface Module (HIM) acts as an interface between a Tricon controller and a Honeywell TDC-3000 control system by means of the Hiway Gateway and Local Control Network (LCN). The HIM can also interface with Honeywell's older TDC 2000 control system by means of the Data Hiway.

The HIM enables higher-order devices on the LCN or Data Hiway, such as computers and operator workstations, to communicate with the Tricon.

The HIM allows redundant BNC connections directly to the Data Hiway and has the same functional capacity as four extended Data Hiway Port (DHP) addresses.

The HIM provides eight Hiway addresses, implements the same slot structure as the DHP, and typically refreshes all data in less than 0.5 seconds. The hot-spare capability allows online replacement of a faulty module.

## HIM Specifications

<b>Model Number</b>	<b>4509</b>
Data Hiway channels	2 isolated (AC coupled)
Poll response switches	2 per channel
Baud rate	250 kilobits per second
Status indicators	PASS (Module Status) FAULT (Module Status) ACTIVE (Module Status) ON LN (HIM Online) H I/F (Hiway Interface) CAL UP (Call-up Received) CH A (Channel A Active) CH B (Channel B Active) XMIT (HIM Transmitting) STD BY IN (Standby Module Inserted) STD BY READY (Standby Module Ready)
Power Module load	< 10 watts
Isolation	500 VDC

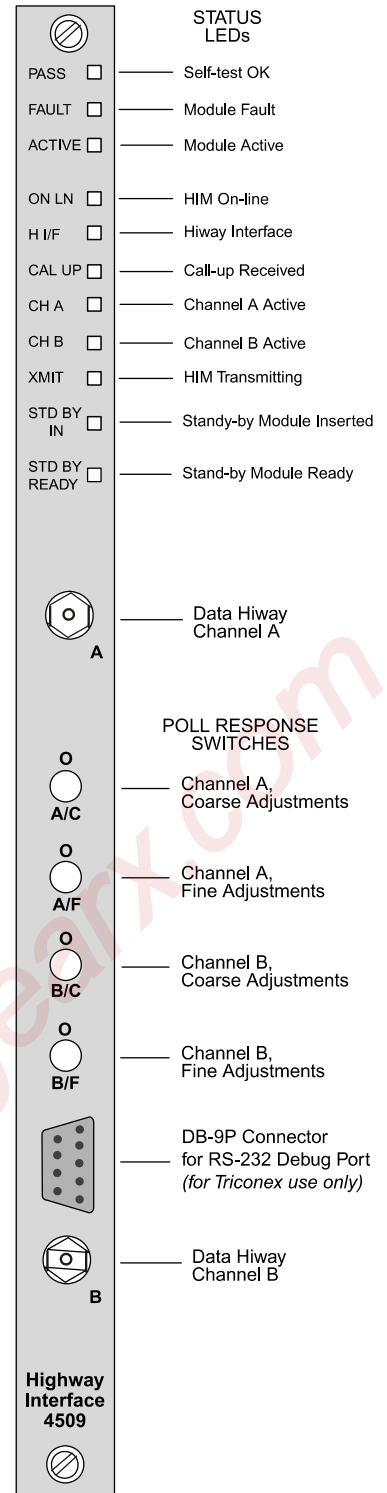

# Product Specifications

## Remote Extender Module (RXM)

RXMs and chassis allow I/O modules to be located several kilometers from the Main Chassis. RXM sets, consisting of three identical modules, serve as repeaters and extenders of the Tricon I/O bus and provide ground loop isolation. A primary RXM set supports three remote locations by connecting to three remote RXM sets housed in a remote chassis. See “System Configuration” on page 11 regarding configurations that use RXMs.

RXM sets are available for fiber-optic cables with a communication rate of 375 kilobits per second. These sets provide maximum immunity against electro-static and electro-magnetic interference, and support configurations with optical modems and fiber-optic point-to-point cabling. Remote sites can be located as far as 7.5 miles (12 kilometers) from the primary site.

The figure at right shows uni-directional cabling for three channels of a remote location. For each channel, one cable carries data transmitted from the primary RXM to the remote RXM, and the other cable carries data received by the primary RXM from the remote RXM. A pair of modules must be wired for each of the three channels, amounting to a total of six cables for each remote location.

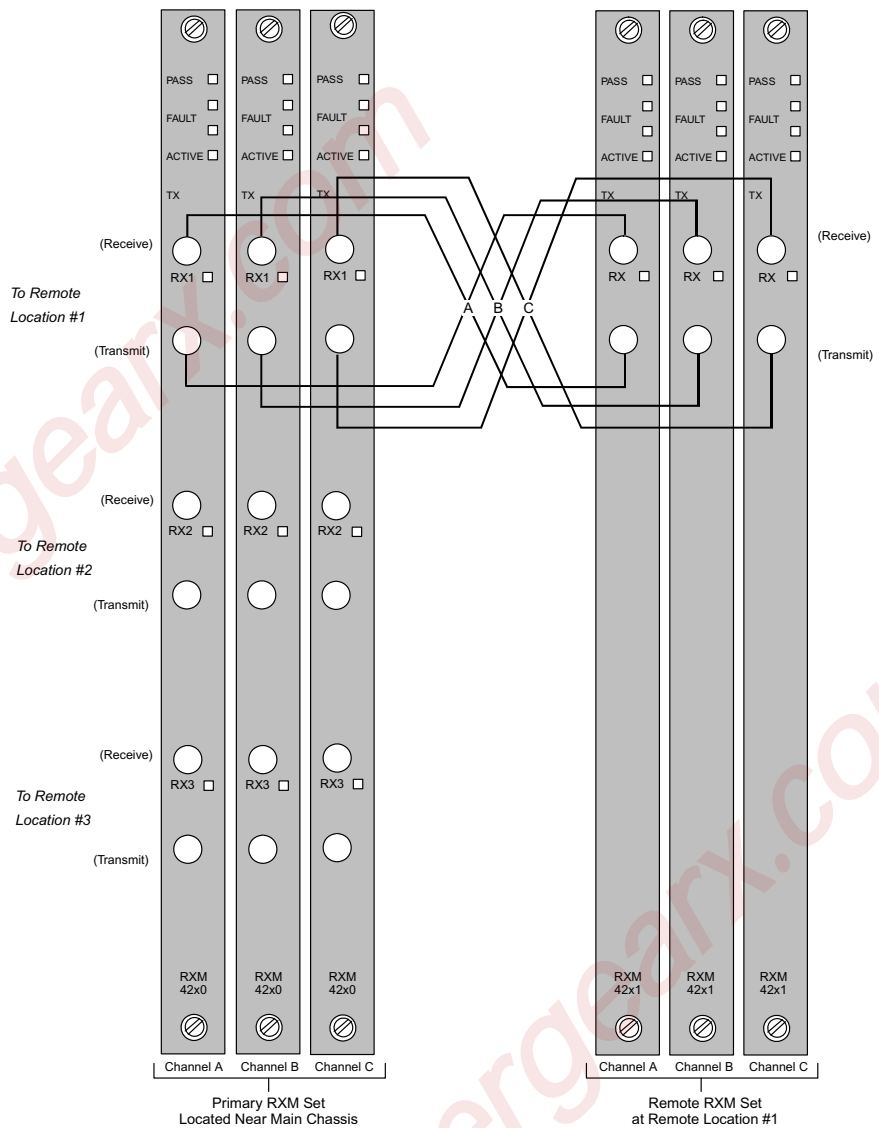

**Sample Wiring for One Remote Location**

**NOTE:** The selection and installation of fiber-optic cabling requires specialized knowledge, training and tools. Triconex recommends hiring a fiber-optic specialist to handle these tasks.

## RXM Specifications

RXM Model	4200-3	4201-3	4210-3	4211-3
RXM Chassis Location	Primary	Remote	Primary	Remote
Cable Type	Multi-mode	Multi-mode	Single-mode	Single-mode
Cable Length Limit	1.2 miles (2 kilometers)	1.2 miles (2 kilometers)	7.5 miles (12 kilometers)	7.5 miles (12 kilometers)
Connectors	6/remote site	6	6/remote site	6
Remote Sites Supported	3	n/a	3	n/a
Modem Ports	Fiber Optic with ST connectors	Fiber Optic with ST connectors	Fiber Optic with ST connectors	Fiber Optic with ST connectors
Diagnostic Indicators	PASS, FAIL, ACTIVE, TX, RX1, RX2, RX3	PASS, FAIL, ACTIVE, TX, RX1, RX2, RX3	PASS, FAIL, ACTIVE, TX, RX1, RX2, RX3	PASS, FAIL, ACTIVE, TX, RX1, RX2, RX3

## TMR Digital Input Modules

Each TMR Digital Input (DI) module has three isolated input channels which independently process all data input to the module. A microprocessor on each channel scans each input point, compiles data, and transmits it to the Main Processors upon demand. Then input data is voted at the Main Processors just prior to processing to ensure the highest integrity. All critical signal paths are 100 percent triplicated for guaranteed safety and maximum availability. Each channel conditions signals independently and provides optical isolation between the field and the Tricon.

All TMR Digital Input Modules sustain complete, ongoing diagnostics for each channel. Failure of any diagnostic on any channel activates the module Fault indicator, which in turn activates the chassis alarm signal. The module Fault indicator points to a channel fault, *not* a module failure. The module is guaranteed to operate properly in the presence of a single fault and may continue to operate properly with certain kinds of multiple faults.

Models 3502E, 3503E, and 3505E can self-test to detect stuck-On conditions where the circuitry cannot tell whether a point has gone to the Off state. Since most safety systems are set up with a

de-energize-to-trip capability, the ability to detect Off points is an important feature. To test for stuck-On inputs, a switch within the input circuitry is closed to allow a zero input (Off) to be read by the optical isolation circuitry. The last data reading is frozen in the I/O communication processor while the test is running.

All TMR Digital Input Modules support hot-spare capability, and require a separate external termination panel (ETP) with a cable interface to the Tricon backplane. Each module is mechanically keyed to prevent improper installation in a configured chassis.

## 32-Point Digital Input Module Specifications

Model Number	3501E/3501T	3502E	3503E	3505E
Type	TMR	TMR with Self-Test	TMR with Self-Test	TMR, Low Threshold
Voltage	115 VAC/VDC	48 VAC/VDC	24 VAC/VDC	24 VDC
Points	32, non-commoned, isolated	32, commoned in groups of 8	32, commoned in groups of 8	32, commoned in groups of 8
AC Range/DC Range	90-155 VAC/VDC	35-95 VAC/VDC	20-42.5 VAC/VDC	20-42.5 VDC
Frequency Range	DC or 47-63 Hz	DC or 47-63 Hz	DC or 47-63 Hz	n/a
Maximum Voltage	155 VAC/VDC	95 VAC/VDC	42.5 VAC/VDC	42.5 VDC
Switching Level				
Off to On	> 86 VAC/VDC	> 32 VAC/VDC	> 18 VAC/VDC	> 12 VDC
On to Off	< 28 VAC/VDC	< 11 VAC/VDC	< 6 VAC/VDC	< 4 VDC
Nominal Turn-On	6-9 mA	6-9 mA	6-9 mA	3 mA to 5 mA
Typical Hysteresis	32 VAC/VDC	7 VAC/VDC	4 VAC/VDC	2 VDC
Input Delay				
OFF to ON/ON to OFF	< 8 ms/< 15 ms	< 8 ms/< 15 ms	< 8 ms/< 15 ms	< 8 ms/< 15 ms
Point Isolation	1,500 VDC/ 2500 VDC <sup>1</sup>	1,500 VDC	1,500 VDC	1,500 VDC
Nominal Input Impedance	> 8.5 KΩ	> 2.9 KΩ	> 1.25 KΩ	> 1.25 KΩ
Nominal Field Power Load				
Per On point	1.5 watts	1.0 watts	0.5 watts	0.5 watts
@ max. field voltage	2.9 watts	3.2 watts	1.5 watts	1.5 watts
Diagnostic Indicators				
Input Status	1 per point	1 per point	1 per point	1 per point
Module Status	PASS, FAULT, ACTIVE	PASS, FAULT, ACTIVE	PASS, FAULT, ACTIVE	PASS, FAULT, ACTIVE
Stuck Test	n/a	On	On	On
Color Code	Red	Dark Red	Dark Red	Dark Red

1. For 3501T.

# Product Specifications

## 64-Point Digital Input Modules

Each 64-point Digital Input (DI) module has three isolated channels which independently process all data input to the module. A microprocessor on each channel scans each input point, compiles data and transmits it to the Main Processors on demand. Then input data is voted at the Main Processors just prior to processing to ensure the highest integrity.

All Digital Input Modules sustain complete, ongoing diagnostics for each channel. A failure on any channel activates the Fault indicator which in turn activates the chassis alarm. A TMR module is guaranteed to operate properly in the presence of a single fault and

may operate properly with certain kinds of multiple faults.

All Digital Input Modules support hot-spare modules and require a separate external termination panel (ETP) with a cable interface to the Tricon backplane. Each module is mechanically keyed to prevent improper installation in a chassis.

The Model 3504E High-Density Digital Input Module continuously verifies the ability of the Tricon to detect transitions to the opposite state. On this TMR module, all critical signal paths are 100 percent triplicated for guaranteed safety and maximum availability. Each channel conditions signals independently between the field and the Tricon.

The Model 3564 Single Digital Input Module is optimized for safety-critical applications where low cost is more important than maximum availability. On single modules, only those portions of the signal path which are required to ensure safe operation are triplicated. Special self-test circuitry detects all stuck-On and stuck-Off fault conditions in less than half a second. If a single module detects an input fault, it reports that point as Off, which may cause a glitch during switch-over to a hot-spare module.

## 64-Point Digital Input Module Specifications

Model Number	3564	3504E
Type	Single, DI	TMR, DI
Voltage	24 VDC	24 or 48 VDC <sup>1</sup>
Points	64, commoned	64, commoned, DC coupled
DC Range	15-30 VDC	20-72 VDC
Maximum Voltage	36 VDC	72 VDC
Switching Level		<u>24 V</u> <u>48 V</u>
OFF to ON	> 15 VDC	>18 VDC    >32 VDC
ON to OFF	< 6 VDC	< 6 VDC    <11 VDC
Nominal Turn-On	2-3 mA	negligible
Typical Hysteresis	4 VDC	4 VDC/7 VDC
Input Delay		
Off to On/On to Off	< 2 ms/< 2 ms	< 10 ms/< 10 ms
Minimum Point Isolation	1,500 VDC	n/a
Nominal Input Impedance	> 3.0 KΩ	> 30 KΩ
Nominal Field Power Load		
Per On point	0.2 watts	negligible
@ maximum field voltage	0.5 watts	negligible
Diagnostic Indicators		
Input Status	1 per point	1 per point
Module Status	PASS, FAULT, ACTIVE	PASS, FAULT, ACTIVE
Stuck Test	On and Off	On and Off
Color Code	Dark Red	Dark Red

1. The voltage is selected using TriStation 1131.

## Pulse Input Module

The Model 3511 Pulse Input (PI) Module provides eight very sensitive, high-frequency inputs. It is optimized for use with non-amplified magnetic speed sensors common on rotating equipment such as turbines or compressors. The module senses voltage transitions from magnetic transducer input devices, accumulating them during a selected window of time (rate measurement). The resulting count is used to generate a frequency or RPM which is transmitted to the Main Processors. The pulse count is measured to 1 micro-second resolution.

The PI module includes three isolated input channels. Each input channel independently processes all data input to the module and passes the data to the Main Processors, which vote on the data to ensure the highest integrity.

Each module provides complete ongoing diagnostics on each channel. Failure of any diagnostic on any channel activates the Fault indicator, which in turn activates the chassis alarm signal. The Fault indicator merely indicates a channel fault, not a module failure. The module is guaranteed to operate properly in the presence of a single fault and may continue to operate properly with certain kinds of multiple faults. The Pulse Input Module supports hot- spare modules.

**WARNING:** *The PI module does not provide a totalization capability—it is optimized for measuring the speed of rotation equipment. For pulse totalization, see Model 3515 on page 38.*

## Relay Output Module

The Model 3636R and 3636T Relay Output (RO) Modules are non-tripli-

cated modules for use on non-critical points which are not compatible with “high-side” solid-state output switches. An example is interfacing with annunciator panels. The Relay Output module receives output signals from the Main Processors on each of three channels. The three sets of signals are then voted, and the voted data is used to drive the 32 individual relays.

Each output has a loopback circuit which verifies the operation of each relay switch independently of the presence of a load, while ongoing diagnostics test the operational status of the module. Failure of any diagnostic activates the Fault indicator, which in turn activates the chassis alarm.

The Relay Output module comes with normally open (NO) contacts. It supports hot-spare modules and requires a separate external termination panel (ETP) with a cable interface to the Tricon backplane.

## Pulse Input Module Specifications

Model Number	3511
Type	TMR, PI
Input Signals	8, non-commoned
Resolution	16 bits
Accuracy	1,000 Hz to 20,000 Hz, $\pm 0.01\%$
Input Characteristics (AC coupled, balanced differential)	
Update Rate	25 ms, typical
Impedance (load)	> 8 KW, 20 KW typical
Common Mode Range	-100 VDC to +100 VDC peak-to-peak
Normal Mode Range	1.5 V to 200 V peak-to-peak
Overrange Protection	$\pm 150$ VDC, continuous
Hysteresis	150 millivolts, typical
Wave Shape	Sine, square, pulse, etc.
Duty Cycle	10% to 90%
Frequency	20 Hz to 20,000 Hz
Current Range	0-20 mA (250-ohm shunt)
Diagnostic Indicators (ON=true)	
Input Status	1 per point
Module Status	PASS, FAULT, ACTIVE
Color	Light Purple

## RO Module Specifications

Model Number	3636R/T
Type	Non-triplicated, RO
Points	32, non-commoned
Voltage Range	125 VAC/VDC, maximum
Current Load	2A, maximum
Minimum Permissible Load	10 mA, 5 VDC
Switching Power, Resistive	2,000 V A, 150 watts maximum
Point Isolation	1,500 VDC 1,900 VDC <sup>1</sup>
Fuses	1 per output (2.5A fast-acting)
Diagnostic Indicators	
Output Status	1 per point
Module Status	PASS, FAULT, ACTIVE
Output Contact	Normally Open
Color Code	Silver Blue

1. For 3636T.

# Product Specifications

## Pulse Totalizer Input Module

The Model 3515 Pulse Totalizer Input (PTI) Module provides 32 individual 31-bit counters that operate independently. The counters are used with active-flow sensors or per-unit sensors to measure a quantity (count) which is transmitted to the Main Processors. At the time specified by the control program, the Main Processors clear a single counter or all counters.

The PTI module has three isolated input channels. Each input channel independently processes all input data and passes it to the Main Processors, where it is voted before processing to ensure the highest integrity.

Each PTI module provides complete ongoing diagnostics on each channel, including channel-to-channel count comparison. Failure of any diagnostic on any channel activates the Fault indicator, which in turn activates the

chassis alarm. The Fault indicator points to a channel fault, not a module failure. The PTI module is guaranteed to operate properly in the presence of a single fault, and may continue to operate with certain kinds of multiple faults.

The PTI module can operate with or without a hot-spare module. If you use a hot-spare module, it re-educates all counter values from the active module.

## Pulse Totalizer Input Module Specifications

Model Number	3515
Type	TMR, Pulse Totalizer
Number of Input Signals	32, non-commoned
Input Frequency Range	0 Hz to 1 KHz
Minimum Input Pulse Width	300 microseconds
Accuracy	
Active Module	± 2 counts
Hot-spare module (maximum error counts during hot replacement)	1-10 >= 100 Hz 0-1 <= 100 Hz
Maximum Count	2,147,483,647 ( $2^{31} - 1$ )
Counter Overflow (worst case @ 1 KHz)	596 Hours (24 days)
Count Overflow Indication	Count goes to negative integer
Count Resets	Individual reset per counter
Recommended Input Voltage Range	42.5 VDC absolute maximum
Count Up Switching Level	Rising edge (Off to On)
Switching Voltages	
Off to On	15 VDC typical, 18 VDC worst case
On to Off	8 VDC typical, 6 VDC worst case
Typical Hysteresis	4 VDC
Normal Turn-on Current	6mA to 9mA
Count Input Delay	< 15 ms
Point Isolation (opto-isolated)	1,500 VDC minimum
Diagnostic Indicators	
On or Off State	1 per point
Module Status	PASS, FAULT, ACTIVE
Logic Power	< 10 watts
Nominal Field Power Load	0.5 watts per On point 1.5 watts @ maximum field voltage
Color Code	Purple

## TMR Digital Output Modules

Each TMR Digital Output (DO) module receives output signals from the Main Processors on each of three channels. Each set of three signals is then voted by special quadruplicated output circuitry on the module. The circuitry produces one voted output signal and passes it to the field termination. The quadruplicated voter circuitry provides multiple redundancy for all critical signal paths, guaranteeing safety and maximum availability.

Each TMR Digital Output Module has a voltage-loopback circuit which verifies the operation of each output switch independently of the presence of a load and determines whether latent faults

exist. Failure of the detected field voltage to match the commanded state of the output point activates the LOAD/FUSE alarm indicator.

In addition, ongoing diagnostics are performed on each channel and circuit of a TMR Digital Output Module. Failure of any diagnostic on any channel activates the Fault indicator, which in turn activates the chassis alarm signal. The Fault indicator merely indicates a channel fault, *not* a module failure. The module is guaranteed to operate properly in the presence of a single fault and may continue to operate properly with certain kinds of multiple faults.

All TMR Digital Output Modules support hot-spare capability, and require a separate external termination panel (ETP) with a cable interface to the Tricon backplane. Each module is mechanically keyed to prevent improper installation in a configured chassis.

Digital outputs are designed to source the current to field devices, so field power must be wired to each output point on the field termination.

## 16-Point Digital Output Module Specifications

Model Number	3601E/3601T	3603B/3603E/3603T	3607E	3604E
Nominal Voltage	115 VAC	120 VDC	48 VDC	24 VDC
Type	TMR, DO	TMR, DO	TMR, DO	TMR, DO
Output Signals	16, non-commoned	16, commoned (3603E/T) 16, non-commoned (3603B)	16, non-commoned	16, non-commoned
Voltage Range	80-155 VAC	90-150 VDC	44-80 VDC	22-45 VDC
Voltage Drop <sup>1</sup>	< 3V, typical	< 1.5V, typical	< 3V, typical	< 4V, typical
Frequency Range	47-63 Hz	n/a	n/a	n/a
Current Ratings, Maximum	2A per point 12A surge/cycle	0.8A per point 4A surge/10 ms	1A per point 5A surge/10 ms	2A per point 10A surge/10 ms
Load Leakage	2 mA maximum @ 60 Hz	2 mA maximum	2 mA maximum	2 mA maximum
Chassis Leakage	4 mA maximum @ 60 Hz	n/a	n/a	n/a
Fuses (on Field Termination)	1 per output, 3A fast-acting	1 per output, 1.0A fast-acting	1 per output, 1.25A fast-acting	1 per output, 2.5A fast-acting
Point Isolation	1,500 VDC/ 2500 VDC <sup>2</sup>	1,500 VDC/ 2500 VDC <sup>3</sup>	1,500 VDC	1,500 VDC
Diagnostic Indicators				
On or Off state	1 per point	1 per point	1 per point	1 per point
Module Status	PASS, FAULT, ACTIVE	PASS, FAULT, ACTIVE	PASS, FAULT, ACTIVE	PASS, FAULT, ACTIVE
Field Alarm	LOAD/FUSE	LOAD/FUSE	LOAD/FUSE	LOAD/FUSE
Color Code	Green	Blue	Light blue	Dark blue

1. **WARNING:** The voltage drop may be significantly higher in some applications.

2. For 3601T.

3. For 3603T.

# Product Specifications

## 16-Point Supervised and 32-Point Supervised/Non-Supervised Digital Output Modules

Designed for the most critical control programs, Supervised Digital Output (SDO) modules meet the needs of systems whose outputs remain in a single state for extended periods of time (in some applications, for years). An SDO module receives output signals from the Main Processors on each of three channels. Each set of three signals is then voted upon by a fully fault-tolerant quadruplicated output switch whose elements are power transistors,

so that one voted output signal is passed to the field termination.

Each SDO module has voltage and current loopback circuitry coupled with sophisticated online diagnostics that verify the operation of each output switch, the field circuit and the presence of a load. This design provides complete fault coverage without the need to influence the output signal.

The modules are called “supervised” because fault coverage is extended to include potential field problems. In other words, the field circuit is *supervised* by the SDO module so that the following field faults can be detected:

- Loss of power or blown fuse
- Open or missing load
- A field short resulting in the load being energized in error
- A shorted load in the de-energized state

Failure to detect field voltage on any output point energizes the power alarm indicator. Failure to detect the presence of a load energizes the load alarm indicator.

All SDO modules support hot-spare modules and require a separate external termination panel (ETP) with a cable interface to the Tricon backplane.

## 16-Point and 32-Point Supervised Digital Output Module Specifications

Model Number	3623/3623T <sup>1</sup>	3624	3625
Nominal Voltage	120 VDC	24 VDC	24 VDC
Type	TMR, Supervised DO	TMR, Supervised DO	TMR, Supervised/Non-Supervised DO
Output Signals	16, commoned	16, commoned	32, commoned
Voltage Range	90-150 VDC	16-30 VDC	16-32 VDC
Maximum Voltage	160 VDC	36 VDC	36 VDC
Voltage Drop	< 1.5 VDC, typical	< 1.5 VDC, typical	< 2.8 VDC @ 1.7A, typical
Power Module Load	< 10 watts	< 10 watts	< 13 watts
Current Ratings, Maximum	0.8A per point 4A surge per 10 ms	0.7A per point 4.8A surge per 10 ms	1.7A per point 7A surge per 10 ms
Minimum Required Load	30 mA	30 mA	10 mA
Load Leakage	4 mA maximum	4 mA maximum	4 mA maximum
Fuses (on Field Termination)	1A fast-acting	n/a—self-protecting	n/a—self-protecting
Point Isolation	1,500 VDC/ 2500 VDC <sup>2</sup>	1,500 VDC	1,500 VDC
Diagnostic Indicators			
On or Off State	1 per point	1 per point	1 per point
Module Status	PASS, FAULT, ACTIVE	PASS, FAULT, ACTIVE	PASS, FAULT, LOAD, ACTIVE
Field Alarm	POWER, LOAD (1 per point)	POWER, LOAD (1 per point)	LOAD (1 per point)
Color Code	Steel blue	Turquoise green	Dark blue

1. CAUTION: Triconex highly recommends that you perform compatibility testing before selecting the Model 3623T module for use in applications that have field wiring lengths over 328 feet (100 meters), cable that is not twisted pair, or atypical loads such as smart devices, strobe lights, or klaxons.

2. For 3623T.



## 8-Point Supervised Digital Output Modules

Designed for the most critical applications, Supervised Digital Output (SDO) modules meet the needs of systems whose outputs remain in a single state for extended periods of time (in some applications, for years). An SDO module receives output signals from the Main Processors on each of three channels. Each set of three signals is then voted upon by a fully fault-tolerant quadruplicated output switch whose elements are mechanical power relays, so that one voted output signal is passed to the field termination.

Each SDO module has voltage and current loopback circuitry coupled with

sophisticated online diagnostics that verify the operation of each output switch, the field circuit and the presence of a load. This design provides complete fault coverage without the need to influence the output signal.

The modules are called “supervised” because fault coverage is extended to include potential field problems. In other words, the field circuit is *supervised* by the SDO module so that the following field faults can be detected:

- Loss of power or blown fuse
- Open or missing load
- A field short resulting in the load being energized in error

- A shorted load in the de-energized state

Failure to detect field voltage on any output point energizes the power alarm indicator. Failure to detect the presence of a load energizes the load alarm indicator. When an optional secondary power supply is used, shorted loads in the Off state can be detected. (This feature is not provided on Model 3611E, an AC module.)

All SDO modules support hot-spare capability, and they require separate external termination panels (ETP) with a cable interface to the Tricon backplane.

### 8-Point Supervised Digital Output Module Specifications

Model Number	3611E	3617E
Nominal Voltage	115 VAC	48 VDC
Type	TMR, Supervised DO	TMR, Supervised DO
Points	8, commoned	8, commoned
Voltage Range	90-155 VAC	36-72 VDC
Frequency Range	47-63 Hz	n/a
Maximum Switching Power	2,000 VA (resistive)	150 W (resistive)
On State Voltage Drop <sup>1</sup>	< 2V, typical	< 2V, typical
Current Ratings, Maximum	2A per point 10A/AC cycle	1A per point 5A/10 ms
Minimum Required Load	50 mA	100 mA
Voltage Range of Secondary Power Supply	n/a	5.00 VDC ±.25 VDC
Chassis Leakage	1mA max. @ 60 Hz	n/a
Load Leakage	4 mA max.	4 mA max.
Fuses (on Field Termination)	1 per output (2.5A fast-acting)	1 per output (1.25A fast-acting)
Point Isolation	1,500 VDC, min.	1,500 VDC, min.
Diagnostic Indicators		
Output Status	POINT, PWR, LOAD,	POINT, PWR, LOAD,
Module Status	PASS, FAULT, ACTIVE	PASS, FAULT, ACTIVE
Color Code	Deep green	Mint green

1. **WARNING:** The voltage drop may be significantly higher in some applications.

# Product Specifications

## Dual Digital Output Module

Dual Digital Output (DDO) modules receive output signals from the Main Processors along a single parallel or series path, and applies a 2-out-of-3 voting process individually to each switch. The switches produce one output signal which is then passed to the field termination. While the quadruplicated output circuitry on TMR modules provides multiple redundancy for all critical signal paths, dual circuitry provides just enough redundancy to ensure safe operation. DDO modules are optimized for those safety-critical control programs where low cost is more important than maximum availability.

DDO modules have a voltage-loopback circuit which verifies the operation of

each output switch independently of the presence of a load and determines whether latent faults exist. Failure of the detected field voltage to match the commanded state of the output point activates the LOAD/FUSE alarm indicator.

In addition, ongoing diagnostics are performed on each channel and circuit of a DDO module. Failure of any diagnostic on any channel activates the Fault indicator, which in turn activates the chassis alarm signal. A dual module operates properly in the presence of most single faults and may operate properly with some kinds of multiple faults, but stuck-Off faults are an exception. If one of the output switches has a stuck-Off fault, the output goes to the Off state and a glitch may occur

during switch-over to a hot-spare module.

DDO modules support hot-spare capability, which allows online replacement of a faulty module. Each module is mechanically keyed to prevent improper installation in a configured chassis.

DDO modules require a separate external termination panel (ETP) with a cable interface to the Tricon backplane. Digital outputs are designed to source the current to field devices, so field power must be wired to each output point on the field termination.

## Dual Digital Output Module Specifications

<b>Model Number</b>	<b>3664/3674</b>
Nominal Voltage	24 VDC
Type	Dual DO, serial (recommended for de-energize-to-trip control programs)
Output Signals	32, commoned
Voltage Range	16-30 VDC
Maximum Voltage	36 VDC
Voltage Drop	< 1.5 VDC, typical
Power Module Load	< 10 watts
Current Ratings, Maximum	2A per point 10A surge per 10 ms
Load Leakage	2 mA maximum
Fuses (on Field Termination)	n/a—self-protecting
Point Isolation	1,500 VDC minimum
Diagnostic Indicators	
On or Off State	1 per point
Module Status	PASS, FAULT, ACTIVE
Field Alarm	LOAD/FUSE
Load Alarm, output stuck-On	3664 — Stuck-On point, all others commanded state - On or Off 3674 — Stuck-On point, all others commanded Off (de-energized)
Load Alarm, output stuck-Off	3664 and 3674 — Stuck-Off point, all others commanded state — On or Off
Color Code	Dark blue

## Analog Input Modules

Analog Input (AI) Modules includes three independent input channels. Each input channel receives variable voltage signals from each point, converts them to digital values, and transmits the values to the three Main Processor modules on demand. In TMR mode, one value is then selected using a mid-value selection algorithm to ensure correct data for every scan.

Sensing of each input point is performed in a manner that prevents a single failure on one channel from

affecting another channel. Each Analog Input Module sustains complete, ongoing diagnostics for each channel. Failure of any diagnostic on any channel activates the Fault indicator for the module, which in turn activates the chassis alarm signal. The module's Fault indicator merely reports a channel fault, *not* a module failure—the module can operate properly with as many as two faulty channels.

Analog Input Modules support hot-spare capability, which allows online replacement of a faulty module.

Analog Input Modules require a separate external termination panel (ETP) with a cable interface to the Tricon backplane. Each module is mechanically keyed for proper installation in a Tricon chassis.

## Analog Input Module Specifications

Model Number	3700/3700A	3701	3703E
Voltage	0-5V, + 6% (only 3700A)	0-10V	0-5V or 0-10V <sup>1</sup> , + 6%
Type	TMR, AI	TMR, AI	TMR, AI
No. of Input Points	32, diff, DC coupled	32, diff, DC coupled	16, diff, isolated
Isolated Points	No	No	Yes
Input Update Rate	55 ms	55 ms	50 ms
Resolution	12 bits	12 bits	12 bits
Accuracy	< .15% of FSR, from 0° to 60°C	< .15% of FSR, from 0° to 60°C	< .15% of FSR, from 0° to 60°C
Input Resistance (load)	30 MΩ (DC), min.	30 MΩ (DC), min.	30 MΩ (DC), min.
Power-Off Resistance	30 KΩ (DC), typical	30 KΩ (DC), typical	30 MΩ (DC), min.
Common Mode Rejection	-80 dB (DC-100Hz), typical	-80 dB (DC-100Hz), typical	-90 dB @ 60Hz, min. -100 dB @ DC, min.
Common Mode Range	-12V to +12V peak	-12V to +12V peak	±200V peak
Leg-to-Leg Isolation	200 KΩ, typical	200 KΩ, typical	20 KΩ, typical
Normal Mode Rejection			
@ 8Hz	-3 dB	-3 dB	-3 dB
@ 60Hz	-17 dB	-17 dB	-17 dB
@ 120Hz	-23 dB	-23 dB	-23 dB
Input Overrange Protection	150 VDC/115 VAC continuous	150 VDC/115 VAC continuous	150 VDC/115 VAC continuous
Current Range	0-20 mA, 250 Ω shunt	0-20 mA, 500 Ω shunt	0-20 mA, 250 Ω shunt for 5V 500 Ω shunt for 10V
Diagnostic Indicators			
Module Status	Pass, Fault, Active	Pass, Fault, Active	Pass, Fault, Active
Color Code	Yellow	Light yellow	Mustard yellow

1. The voltage is selected using TriStation 1131.

# Product Specifications

## Analog Input Module Specifications

Model Number	3704E	3720	3721
Voltage	0-5V or 0-10V <sup>1</sup> , + 6%	0-5VDC, + 6%	0 to 5 VDC or -5 to +5 VDC <sup>1</sup> , + 6%
Type	TMR, AI	TMR, AI	TMR, AI
No. of Input Points	64, commoned	64, single-ended	32 differential, DC-coupled
Isolated Points	No	Yes	Yes
Input Update Rate	75 ms	10 ms	10 ms
Resolution	12 bits	12 bits or 14 bits programmable	12 bits or 14 bits programmable
Accuracy	< 0.25% of FSR from 0° to 60°C	< 0.15% of FSR from 0° to 60° C	< 0.15% of FSR from 0° to 60° C
Input Resistance (load)	30 MΩ (DC), min.	10 MΩ (DC), min.	10 MΩ (DC), min.
Power-Off Resistance	30 kΩ (DC), typical	140 kΩ (DC), typical	140 kΩ (DC), typical
Common Mode Rejection	n/a	n/a	-85 dB (DC - 100 Hz)
Common Mode Range	n/a	n/a	-12V to +12V peak
Leg-to-Leg Isolation	200 kΩ, typical	420 kΩ, typical	420 kΩ, typical
Normal Mode Rejection	-1 dB @ 8Hz -12 dB @ 60Hz -18 dB @ 120Hz	-3 dB @ 8Hz -17 dB @ 60Hz -23 dB @ 120Hz	-3 dB @ 23 Hz -8 dB @ 60 Hz -14 dB @ 120 Hz
Input Overrange Protection	150 VDC/115 VAC continuous	150 VDC/115 VAC continuous	150 VDC/115 VAC continuous
Current Range	0-20 mA, 250 Ω shunt for 5V 500 Ω shunt for 10V	0-20 mA (plus 6% over-range) with 250 Ω shunt resistor	0-20 mA with 250 Ω shunt resistor
Diagnostic Indicators			
Module Status	PASS, FAULT, ACTIVE	PASS, FAULT, ACTIVE, FIELD	PASS, FAULT, ACTIVE, FIELD
Color Code	Copper	Yellow	Yellow

1. The voltage is selected using TriStation 1131.

## Analog Output Modules

Analog Output (AO) modules receive output signals from the Main Processor module on each of three channels. Each set of data is then voted and a healthy channel is selected to drive the outputs. Each module monitors its own current outputs (as input voltages) and maintains an internal voltage reference to provide self-calibration and module health information.

Each channel on a module has a current loopback circuit which verifies the accuracy and presence of analog signals independently of load presence or channel selection. The module's design prevents a non-selected channel from driving an analog signal to the

field. In addition, ongoing diagnostics are performed on each channel and circuit of the module. Failure of any diagnostic test deactivates the faulty channel and activates the Fault indicator and the chassis alarm. The module Fault indicator merely indicates a channel fault, not a module failure. The module continues to operate properly with as many as two channels failed. Open loop detection is provided by a LOAD indicator which activates if the module is unable to drive current to one or more outputs.

The module provides for redundant loop power sources with individual power and fuse indicators called PWR1 and PWR2. External loop power

supplies for analog outputs must be provided by the user. A LOAD indicator activates if an open loop is detected on one or more output points. PWR1 and PWR2 are on if loop power is present.

AO modules support hot- spare capability, which allows online replacement of a faulty module.

AO modules require a separate external termination panel (ETP) with a cable interface to the Tricon backplane. Each module is mechanically keyed to prevent improper installation in a configured chassis.

The Model 3805H module has been modified to support increased inductive

loads. It is fully compatible for use in all applications of the 3805E module.

The Model 3806E and Model 3807 modules are optimized for turbomachinery control.

The Model 3806E High Current AO Module has two 20 to 320 mA outputs to drive servo actuators.

The Model 3807 BiPolar AO Module has four -60 to + 60 mA outputs to drive servo coils in servo-control applications. The termination panel for the

Model 3807 contains four hard-wired coil diagnostic inputs. The Model 3807 is designed for control applications only, and should not be used in safety applications.

### Analog Output Module Specifications

Model Number	3805E/3805H	3806E	3807																								
Type	TMR, AO	TMR, AO	TMR, AO																								
Output current range	4-20 mA output (+6% overrange)	4-20 mA and 20-320 mA	-60 to 60 mA																								
Number of points	8 output	6 (4-20 mA) output; 2 (20-320 mA) output	4 bipolar output																								
Isolated points	No, commoned return, DC coupled	No, commoned return, DC coupled	No, commoned return, DC coupled																								
Resolution	12 bits	12 bits	13 bits																								
Output Accuracy	<0.25% (in range of 4-20 mA) of FSR (0-21.2 mA), from 32° to 140° F (0° to 60° C)	<0.25% (in range of 4-20 mA) of FSR (0-21.2 mA and 0-339.2 mA), from 32° to 140° F (0° to 60° C)	< 0.25% (in range of -60 to 60 mA) of Full Scale Range (FSR), from 0° to 60° C. FSR = 120 mA.																								
External loop power (reverse voltage protected)	+42.5 VDC, maximum +24 VDC, nominal	+42.5 VDC, maximum +24 VDC, nominal	24 VDC -15%/+20%, +5% ripple																								
Output loop power requirements	<table border="1"> <thead> <tr> <th rowspan="2">Load (Ohms)</th> <th rowspan="2">Loop power required</th> <th colspan="2">Max. load vs. external loop voltage</th> <th rowspan="2">Independent; For ± 60mA, maximum load is 150 ohms and is independent of variations in external loop power supply voltage.</th> </tr> <tr> <th>4-20 mA</th> <th>16-320 mA</th> </tr> </thead> <tbody> <tr> <td>250</td> <td>&gt; 20 VDC (1 amp minimum)</td> <td>20 VDC ≤ 275</td> <td>≤ 15</td> <td rowspan="4"></td> </tr> <tr> <td>500</td> <td>&gt; 25 VDC (1 amp minimum)</td> <td>24 VDC ≤ 475</td> <td>≤ 25</td> </tr> <tr> <td>750</td> <td>&gt; 30 VDC (1 amp minimum)</td> <td>28 VDC ≤ 650</td> <td>≤ 40</td> </tr> <tr> <td>1000</td> <td>&gt; 35 VDC (1 amp minimum)</td> <td>32 VDC ≤ 825</td> <td>≤ 50</td> </tr> </tbody> </table>			Load (Ohms)	Loop power required	Max. load vs. external loop voltage		Independent; For ± 60mA, maximum load is 150 ohms and is independent of variations in external loop power supply voltage.	4-20 mA	16-320 mA	250	> 20 VDC (1 amp minimum)	20 VDC ≤ 275	≤ 15		500	> 25 VDC (1 amp minimum)	24 VDC ≤ 475	≤ 25	750	> 30 VDC (1 amp minimum)	28 VDC ≤ 650	≤ 40	1000	> 35 VDC (1 amp minimum)	32 VDC ≤ 825	≤ 50
Load (Ohms)	Loop power required	Max. load vs. external loop voltage				Independent; For ± 60mA, maximum load is 150 ohms and is independent of variations in external loop power supply voltage.																					
		4-20 mA	16-320 mA																								
250	> 20 VDC (1 amp minimum)	20 VDC ≤ 275	≤ 15																								
500	> 25 VDC (1 amp minimum)	24 VDC ≤ 475	≤ 25																								
750	> 30 VDC (1 amp minimum)	28 VDC ≤ 650	≤ 40																								
1000	> 35 VDC (1 amp minimum)	32 VDC ≤ 825	≤ 50																								
Over-range protection	+42.5 VDC, continuous	< +42.5 VDC	+36 VDC, continuous																								
Switch time on leg failure	< 10 ms, typical	< 10 ms, typical	< 10 ms, typical																								
Diagnostic Indicators	<table border="1"> <thead> <tr> <th>Module status (one each per module)</th> <th>3805E/3805H</th> <th>3806E</th> <th>3807</th> </tr> </thead> <tbody> <tr> <td>Module status (one each per module)</td> <td>PASS, FAULT, ACTIVE, LOAD, PWR1, PWR2</td> <td>PASS, FAULT, ACTIVE, LOAD, PWR1, PWR2</td> <td>PASS, FAULT, ACTIVE, LOAD, PWR1, PWR2</td> </tr> </tbody> </table>			Module status (one each per module)	3805E/3805H	3806E	3807	Module status (one each per module)	PASS, FAULT, ACTIVE, LOAD, PWR1, PWR2	PASS, FAULT, ACTIVE, LOAD, PWR1, PWR2	PASS, FAULT, ACTIVE, LOAD, PWR1, PWR2																
Module status (one each per module)	3805E/3805H	3806E	3807																								
Module status (one each per module)	PASS, FAULT, ACTIVE, LOAD, PWR1, PWR2	PASS, FAULT, ACTIVE, LOAD, PWR1, PWR2	PASS, FAULT, ACTIVE, LOAD, PWR1, PWR2																								
Color code	Pea green	Light green	Light green																								

# Product Specifications

## Thermocouple Input Modules

Thermocouple Input (TC) modules include three independent input channels. Each input channel receives variable voltage signals from each point, performs thermocouple linearization and cold-junction compensation, and converts the result to degrees Celsius or Fahrenheit. Each channel then transmits 16-bit signed integers representing 0.125 degrees per count to the three Main Processors on demand. In TMR mode, a value is then selected using a mid-value selection algorithm to ensure correct data for every scan.

Each Thermocouple Input Module is programmable to support one thermocouple type, selected from J, K and T for standard Thermocouple Input Modules and from J, K, T and E for

isolated Thermocouple Input Modules. The isolated module allows users to select upscale or downscale burnout detection with TriStation 1131. For non-isolated modules, upscale or downscale burnout detection depends on the field termination selected.

Triplicated temperature transducers residing on the field termination panel support cold-junction compensation. Each channel of a Thermocouple Input Module performs auto-calibration using internal precision voltage references. On the isolated module, a faulting cold-junction transducer is annunciated by a cold-junction indicator on the front panel.

Each module performs complete ongoing diagnostics on each channel. Failure of any diagnostic on any

channel activates the Fault indicator, which in turn activates the chassis alarm signal. The module Fault indicator merely reports a channel fault, not a module failure. The module continues to operate properly with as many as two faulty channels.

Thermocouple Input Modules support hot-spare capability, which allows online replacement of a faulty module. Thermocouple Input Modules require a separate external termination panel (ETP) with a cable interface to the Tricon backplane.

Each module is mechanically keyed to prevent improper installation in a configured chassis.

## Thermocouple Input Module Specifications

Model Number	3706A	3708E
Type	TMR, thermocouple	TMR, thermocouple
Number of input signals	32 differential, DC coupled	16 differential, isolated
Isolated points	No	Yes
Input update rate	50 ms, maximum <sup>1</sup>	50 ms
Thermocouple types supported <sup>2</sup>	J, K, T	J, K, T, E
Accuracy/temp range	See Table A	See Table B
Input resistance (load)	22 M $\Omega$ (DC), typical	30 M $\Omega$ (DC), minimum
Noise rejection		
Common mode	-85 dB @ 0-60 Hz, minimum -95 dB @ DC, typical	-90 dB @ 0-60 Hz, minimum -100 dB @ DC, minimum
Normal mode	-17 dB @ 60 Hz	-3 dB @ 8 Hz, typical -17 dB @ 60 Hz, typical
Common mode range	$\pm$ 10 VDC max. (channel-to-channel or channel-to-ground)	$\pm$ 200 VDC, max (channel-to-channel or channel-to-ground)
Leg-to-leg isolation	200 K $\Omega$ , typical	20 K $\Omega$ , typical
Input point protection	110 VAC, continuous	110 VAC, continuous
Reference junction compensation range	32°-140°F (0°-60°C)	32°-140°F (0°-60°C)
Diagnostic indicators	PASS, FAULT, ACTIVE	PASS, FAULT, ACTIVE, CJ FAULT
Color code	Tan	Deep yellow

1. Inputs frozen for one second upon insertion of spare module.

2. Selected using TriStation 1131.

### Accuracy of Thermocouple Types for Model 3706A

TC Type	Temperature Range	Accuracy <sup>1</sup> (TC Termination Module @ 32-140°F [0-60°C])	
		T <sub>a</sub> = 77°F (25°C) (Typical)	T <sub>a</sub> = 32-140°F (0-60°C) (Maximum)
J	-250 to 32°F (-157 to 0°C)	± 5.0°F (2.8°C)	± 7.0°F (3.9°C)
	>32 to 2000°F (0 to 1093°C)	± 4.0°F (2.3°C)	± 5.0°F (2.8°C)
K	-250 to 32°F (-157 to 0°C)	± 6.0°F (3.4°C)	± 9.0°F (5.0°C)
	>32 to 2500°F (0 to 1371°C)	± 4.0°F (2.3°C)	± 6.0°F (3.4°C)
T	-250 to 32°F (-157 to 0°C)	± 5.0°F (2.8°C)	± 9.0°F (5.0°C)
	>32 to 752°F (0 to 400°C)	± 3.0°F (1.7°C)	± 5.0°F (2.8°C)

### Accuracy of Thermocouple Types for Model 3708E

TC Type	Temperature Range	Accuracy <sup>1</sup> (TC Termination Module @ 32-140°F [0-60°C])	
		T <sub>a</sub> = 77°F (25°C) (Typical)	T <sub>a</sub> = 32-140°F (0-60°C) (Maximum)
J	-238 to 32°F (-150 to 0°C)	± 3.0°F (1.7°C)	± 9.0°F (5.0°C)
	>32 to 1400°F (0 to 760°C)		± 5.5°F (3.1°C)
K	-238 to 32°F (-150 to 0°C)	± 4.0°F (2.3°C)	± 8.0°F (4.5°C)
	>32 to 2284°F (0 to 1370°C)		± 7.0°F (3.9°C)
T	-250 to 32°F (-161 to 0°C)	± 3.0°F (1.7°C)	± 8.5°F (4.8°C)
	>32 to 752°F (0 to 400°C)		± 4.5°F (2.5°C)
E	-328 to 32°F (-200 to 0°C)	± 3.0°F (1.7°C)	± 8.0°F (4.5°C)
	>32 to 1830°F (0 to 999°C)		± 5.0°F (2.8°C)

1. Accuracy specifications account for errors related to reference-junction compensation, but do not account for errors caused by temperature gradients between the temperature transducers and the TC terminations. The user is responsible for maintaining a uniform temperature across the TC Termination Module.

# Product Specifications

## HART Interface Modules

Highway Addressable Remote Transducer (HART) is an industry standard field bus protocol that superimposes a Frequency Key Shifted (FSK) signal onto the 4-20 mA loop. The Tricon Model 2071H HART Multiplexer Module that is incorporated into each of the HART Interface Modules capacitively couples the HART signal to the AI or AO signals. The HART signals are approximately  $\pm 0.5$  mA at 1,200

and 2,200 Hz. These frequencies are high enough that the low-bandwidth loop is unaffected and the HART electronics can impose and extract the HART signals easily.

HART communication through the HART multiplexer is separate from the Tricon system and is certified not to interfere with the 4-20 mA safety signals of the Analog Input and Analog Output Modules.

Only Tricon v10.4.x and later systems can use HART Interface Modules; earlier Tricon systems must upgrade to Tricon v10.4.x. The chassis requirements for using HART Interface Modules in a system upgraded to Tricon v10.4.x differ depending on the original system version, as described in the Tricon Chassis Usage for HART Communication table.

## HART Interface Module Specifications

Model Number	2770H	2870H
Type	HART Analog Input Interface	HART Analog Output Interface
Compatible Modules	3700A, 3721	3805E, 3805H
Number of signals	32 input	8 output
Input/Output type	4-20 mA, 0-5 VDC input	4-20 mA, 0-5 VDC output
HART MUX module	2071H (includes the Triconex 4850 HART Multiplexer)	2071H (includes the Triconex 4850 HART Multiplexer)
Status indicator: HART MUX module	PWR, FAULT, HOST, HART	PWR, FAULT, HOST, HART
HART protocol	HART Field Communication Protocol, Revision 5.0–7.0	HART Field Communication Protocol, Revision 5.0–7.0
Logic power	< 5 Watts	< 5 Watts

## Tricon Chassis Usage for HART Communication

If Your Original System Version is...	Upgrade to...	Install HART Interface Modules in Chassis...
Tricon v10.4.x or later (High-Density)	n/a	<ul style="list-style-type: none"> <li>Model 8121 Enhanced Low-Density Expansion Chassis</li> </ul>
Tricon v10.0.x – 10.3.x (High-Density)	Tricon v10.4.x	<ul style="list-style-type: none"> <li>Model 8121 Enhanced Low-Density Expansion Chassis</li> </ul>
Tricon v9.x (High-Density)	Tricon v10.4.x	<ul style="list-style-type: none"> <li>Model 8121 Enhanced Low-Density Expansion Chassis</li> </ul>
Tricon v6.x – v10.x (Low-Density)	Tricon v10.4.x	<ul style="list-style-type: none"> <li>Model 8100-x Main Chassis</li> <li>Model 8101 Low-Density Expansion Chassis</li> <li>Model 8102 Low-Density RXM Chassis</li> <li>Model 8121 Enhanced Low-Density Expansion Chassis</li> </ul>



---

*A termination panel and associated cable pass signals to or from the field, permitting replacement of I/O Modules without disturbing field wiring.*

## *Field Termination Options*

---

There are two general types of field termination products available from Triconex:

- External termination panels
- Cables

All termination panels and cables are built to withstand harsh industrial environments. The environmental specifications for components used on these products are the same as for a Tricon chassis. (See “[General Environmental and EMC Specifications](#)” on page 21 for details.)

### **External Termination Panels**

An external termination panel (ETP) is an electrically-passive printed circuit board (PCB) to which field wiring is easily attached. A panel connector, terminal blocks and various components are mounted to the PCB and enclosed in a plastic housing. A termination panel and associated cable pass input signals from the field directly to an input module, or pass output signals from an output module directly to field wiring. This arrangement permits the removal or replacement of I/O modules without disturbing field wiring.

External termination panels allow you to marshal field signals in a separate enclosure up to 99 feet (30 meters) from a Tricon.

Standard termination panels are best for remote marshaling of field wiring where maximum flexibility, high density and simple maintenance is desired.

A standard termination panel consists of a PCB with all necessary components—such as two-piece terminal blocks, resistors, fuses and blown-fuse indicators—mounted on a DIN rail-compatible plastic housing. The housing snaps into mounting rails in accordance with DIN 50 022.

Compression terminals on the standard panel are designed for use with 24- to 12-gauge (0.3 mm<sup>2</sup> to 2.1 mm<sup>2</sup>) wiring. Some panels have an optional current-limiting series resistor, others have a fuse with a blown-fuse indicator, to protect the field wiring and field device.

Standard termination panels are pre-configured for specific applications. For instance, the thermocouple input termination panel provides cold-junction temperature sensors and can be ordered with upscale, downscale or programmable burnout detection. A standard termination panel for analog voltage inputs provides commoned signal returns, while the current-mode version has a precision resistor at each input point to convert current to voltage.

Each standard termination panel is packaged with a matched interface



**Tricon Chassis with External Termination Panels and Standard 10' Cables**

# Field Termination Options

cable that connects the panel to the backplane of a Tricon chassis. A female connector at one end of the cable is keyed to match the male connector on the Tricon backplane. A male connector on the other end of the cable attaches to the standard termination panel. Two types of cables are available—one that exits the Tricon backplane at a ninety-degree angle and one that exits at a zero-degree angle (straight, front-entry).

External termination panel model numbers that end with a “Z” contain zero-degree interface cables. Model numbers for ninety-degree configurations are referenced throughout this guide. It is implied that where a model number is referenced for a ninety-degree configuration, a zero-degree configuration also is available.

Zero-degree cables are designed to be used with G-Series Enclosures for Tricon controllers that have front access. For more information on G-Series Enclosures for Tricon Systems, see the G-Series Enclosures Product Specification Sheet, PSS Number: PSS 21H-2X8 B3, on the IPS Global Client

Support (GCS) Web site at <http://support.ips.invensys.com>.

In addition to standard termination panels, there are other types of termination panels, including:

- Basic termination panels
- Hazardous location (nonincendive) termination panels
- Termination panels with interposing relays
- Bypass panels for digital inputs
- Termination panels with RTD/TC/AI input signal conditioning
- Termination panels for 3603B digital output modules
- Termination panels for 3806E analog output modules

## Basic Termination Panels

Basic termination panels are a low-cost means of connecting field wiring to a Tricon. However, basic termination panels do not provide any components other than a 56-pin connector and terminal blocks. These two components are mounted on a DIN rail-compatible plastic housing that snaps into

mounting rails in accordance with DIN 50 022. The user must provide any other components required by his application.

Other features of the basic termination panels are the same as for the standard panels.

## Hazardous Location (Nonincendive) Termination Panels

Hazardous location (nonincendive) termination panels are suitable for use in Zone 2 (ATEX), and Class 1, Division 2 (North America) field circuits. These panels contain extra circuitry designed to limit power available to the field terminals and have been examined and certified by TÜV Rheinland as being nonincendive. This guarantees that if the field wires are accidentally opened, shorted, or grounded, and the Tricon is operating normally, the wiring and attached devices will not release sufficient energy to cause ignition in the specified flammable atmosphere.

## Termination Panels with Interposing Relays

Interposing relays are recommended for applications that have load currents greater than 2 amps, or field voltages greater than 115 VAC which require field-circuit conversion or compatibility with motor-starter circuits.

Each interposing relay provides an auxiliary contact that can be connected to a digital input module by means of an optional loopback cable to verify relay activation by the digital output module. Interposing relay panels use compact general-purpose power relays for maximum reliability and can be used with most digital output modules.

## Bypass Panels for Digital Inputs

Bypass termination panels can be used to connect digital inputs using a bank of 32 pre-wired switches. The bypass panel has a master keyswitch and termi-

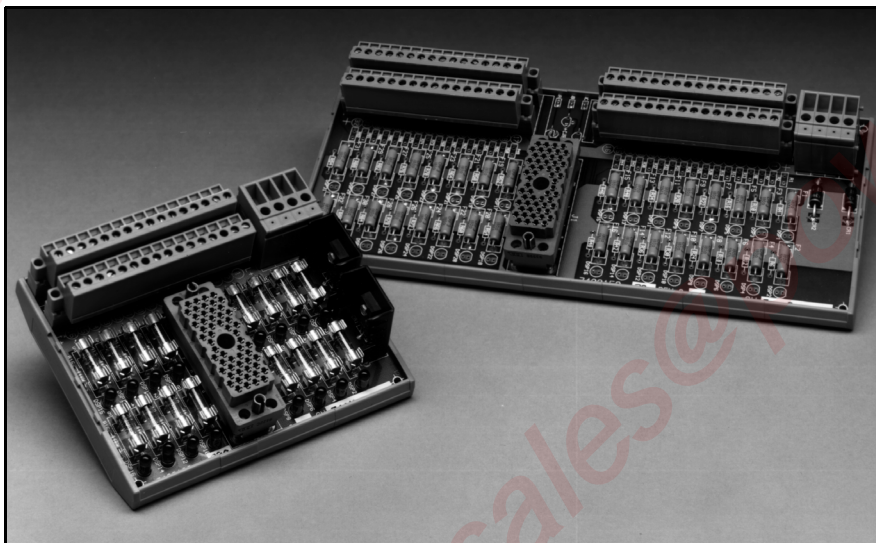

Standard Termination Panels in 16-Point and 32-Point Styles

nals for redundant +24 VDC power sources. Each input point contains an On status indicator and a position for a user-defined label. Each bypass termination panel comes with one or two 10-foot cables for connecting the termination panel to a Tricon backplane.

### Termination Panels for Use with Signal Conditioners

Termination panels which use industry-standard analog signal conditioners provide a flexible, user-configurable interface to resistive thermal devices (RTDs), thermocouples, and 4-20 mA transmitters. Each termination panel supports 16 points and each analog module can support up to 2 panels.

These termination panels are compatible with any signal conditioners in the 1 to 5 volt output range. For example, the 7B series of signal conditioners from Analog Devices are known to work well.

These signal conditioners can be purchased from Triconex, or directly from Analog Devices at:

- <http://www.analog.com/IOS>
- 1-800-426-2564 in the USA
- 781-461-3100 from anywhere in the world

### Fanned-Out Cables

Fanned-out cables are a low-cost alternative to using external termination panels. Fanned-out cables allow you to marshal field signals in a separate enclosure up to 99 feet (30 meters) from a Tricon. One end of a fanned-out cable has a female connector that connects to a Tricon chassis backplane. The other end of the cable contains 50 fanned-out leads, each individually labeled with its corresponding connector pin number.

Each fanned-out cable has the following characteristics:

- PVC outer covering
- 56-pin connector at one end
- 50 stranded, stripped, tinned and labeled 22-gauge leads at opposite end

Fanned-out cables should only be used with digital input and digital output modules. They are not certified for use with analog signals. Contact the IPS Global Client Support (GCS) center if you need a fanned-out cable for handling analog signals.

Although the normal length of all cables is 10 feet (3 meters), any length cable can be ordered up to 99 feet (30 meters) in 10-foot increments, using the last two digits of the cable model number to specify the length in feet. For example, the model number 9101-050F specifies a 50-foot cable instead of the normal 10-foot cable.

### Termination Configuration Options

Terminations are available in various factory configurations:

- *Non-commoned* Terminations can accommodate individual power supplies for each point.
- *Commoned* Terminations can support one power supply which is shared by multiple points. Points can be commoned in groups of 8 and groups of 16.
- Analog signals can be read as *3-wire transmitter inputs*, *voltage inputs* or *current inputs*.
- Thermocouple terminations provide cold-junction temperature sensors and are available for either *upscale* or *downscale burnout detection*. For Model 3706A, upscale or downscale burnout detection depends on which

termination panel is installed. For Model 3708E, upscale or downscale burnout detection is configured with TriStation 1131.

The “Termination Options” table (on the next two pages) shows the available termination choices for each I/O module and gives the correct model number for each choice.

### Over-Current Protection

Non-basic termination panels offer over-current protection in various ways:

- Fuses for individual points and/or field power sources
- Series resistors
- Self-protection for digital output and analog output modules

If you are using basic termination panels, you must supply your own components for over-current protection.